



Known for excellence.
Built on trust.

GEOTECHNICAL

ENVIRONMENTAL

ECOLOGICAL

WATER

CONSTRUCTION
MANAGEMENT

249 Vanderbilt Avenue
Norwood, MA 02062
T: 781.278.3700
F: 781.278.5701
F: 781.278.5702
www.gza.com

Revised July 11, 2023

File No. 01.0177018.00

Mr. Ross Tsantoulis
Woodard & Curran, Inc.
40 Shattuck Road, Suite 110
Andover, Massachusetts 01810

Re: Geotechnical Engineering Report
North Street Culvert Replacement over White Brook
Agawam, Massachusetts

Dear Mr. Tsantoulis:

In accordance with our agreement dated December 15, 2022, GZA GeoEnvironmental, Inc. (GZA) is pleased to submit this geotechnical report to Woodard & Curran, Inc. (W&C, client) for the proposed culvert replacement at North Street over White Brook in Agawam, Massachusetts. This report summarizes the results of subsurface explorations and presents recommendations for design and construction of foundations for the proposed culvert replacement and associated retaining walls. This revised report supersedes the previous version dated May 23, 2023.

We understand that Woodard & Curran was engaged by the Town of Agawam to provide engineering services associated with the above-referenced culvert and that engineering work associated with the culvert replacement at North Street will be reviewed by MassDOT. GZA's geotechnical evaluation has been performed with the intent to satisfy the requirements of the MassDOT LRFD Bridge Manual.

Elevations (El.) indicated in this report are in feet and are referenced to North American Vertical Datum 1988 (NAVD 88). This report is subject to the limitations in **Appendix A**.

BACKGROUND

Our understanding of the project is based on the following information:

- Emails and telephone/online conversations with W&C;
- Preliminary Design plans for the proposed culvert and retaining wall system (11 sheets) prepared by Contech Engineered Solutions LLC (Contech, culvert and retaining wall designer) entitled "ALSP Single Radius Arch W/ Full Invert 18'-0" Span x 7'8" Rise (32N) – North Street, Agawam MA," dated February 26, 2023;
- Calculations (4 pages) prepared by Contech entitled "Structural Design Check for Corrugated Aluminum Plate Arch," dated February 26, 2023;
- Section view plan of the proposed culvert structure prepared by Contech entitled "Grid ALSP SRA- 18 x 7-8," transmitted on February 17, 2023;
- Preliminary Design plans prepared by W&C entitled "North Street Culvert Replacement," dated February 16, 2023;
- Site existing conditions and topographic survey plans prepared by WSP USA, Inc. entitled "190299K_NORTH STREET," transmitted on January 10, 2023;



- A geotechnical letter report prepared by OTO for the proposed North Street culvert crossing over White Brook, dated January 6, 2021;
- A structural design report prepared by Koontz Bryant Johnson Williams, Inc. (KBJW Report No. 23-26882-001-02-0523 dated May 5, 2023; and
- Readily available on-line information.

EXISTING CONDITIONS

This project includes replacement of the existing culvert carrying the flow from White Brook below North Street in Agawam, Massachusetts. Refer to the attached **Figure 1** for the site location.

The existing culvert consists of an approximately 3- to 3.5-foot-diameter, 116-foot-long corrugated metal pipe (CMP) that crosses below North Street at skew angle of about 5 degrees (refer to **Photo 1**).



The existing culvert invert elevations (El.) at the upstream and downstream sides (north and south, respectively) are approximately 121.4 and 115.3 feet, respectively. No headwalls or wingwalls are present at the upstream and downstream ends of the existing culvert where grade changes transition relatively quickly from the roadway shoulder grades to the culvert invert grades at slopes of about 2 horizontal to 1 vertical (2H:1V) to 1H:1V, respectively. The slope surface cover at the upstream and downstream ends of the culvert consists of a mix of partial rip-rap coverage mixed with vegetated/wooded land.

North Street, at the location of the existing and proposed culvert, is an approximately 26-foot-wide two-lane, two-way traffic roadway that runs downhill in a generally west to east direction from approximate El. 137.5 to 134. Based on site observations and the referenced preliminary design drawings, overhead electric lines and several underground utilities (natural gas, telecommunications, drain, sanitary sewer, water) appear to be present within or adjacent to the roadway, above the existing culvert.

Photo 1: Upstream (South) End of Existing Culvert

PROPOSED CULVERT REPLACEMENT

We understand, to meet the hydraulic design requirements, the North Street culvert pipe will be replaced by an aluminum arch culvert with approximate width, height, and length dimensions in feet of 18 by 7.7 by 119, respectively. A two-foot-thick layer of river sediment material will be placed on top of the culvert base mat. A section view of the proposed arch is shown in **Figure A**.

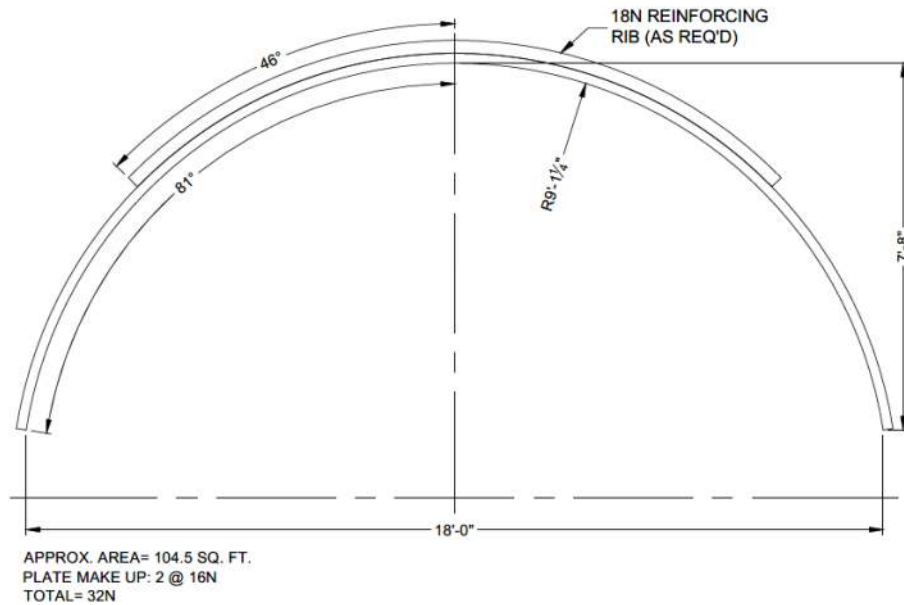

Figure A – Typical Proposed Single-Radius Aluminum Arch Culvert Transverse Section (not to scale)

Because the culvert structure span is greater than 10 feet, its replacement is subject to MassDOT design requirements and review (with respect to the structure being classified as a “bridge”) in accordance with MGL Chapter 85, Section 35. The culvert designer, Contech Engineering Solutions LLC (Contech), has indicated target maximum differential and total settlement criteria for the proposed aluminum arch culvert structure are approximately 1-inch and 2-inches, respectively.

Additional information related to the existing and proposed culverts is summarized in **Table A**.

Table A: Summary of Existing and Proposed Culvert Information

Location of Culvert	Existing Culvert Type & Geometry	Proposed Culvert Type & Geometry (ft) ¹	Existing & Proposed Pavement El. (ft)	Existing Culvert Invert El. (ft)	Proposed Culvert Invert El. (ft)
North Street over White Brook	3' to 3.5' Diameter, 115'± Long CMP Pipe	18' wide span, 7.7' high, 119' long, closed bottom Aluminum Plate Arch	134 to 137.5	115.3 to 121.4	115.3 to 121

Note: 1) Span length is as defined by MassDOT Small Bridge Program Figures 1, 2, and 3 from the MassDOT website: <https://www.mass.gov/service-details/determining-if-a-structure-is-a-bri>.

We understand that the proposed headwalls and wingwalls (e.g. retaining walls) at the upstream and downstream sides of the proposed culvert are anticipated to consist of corrugated aluminum panels seated on a 12-inch-thick bed of crushed stone, which will be laterally supported by steel anchor rods connected to deadmen consisting of aluminum structural plates (approximately 20-inch-tall by 29-inch-wide by 0.15-inch-thick) at approximately 4.5-foot lateral and 5.5-foot vertical center-to-center spacing. The proposed retaining walls will accommodate the proposed grade changes (proposed fill heights) of up to about 9 feet. The bottom of the wall panels will extend



approximately 2.5 feet below the proposed invert elevations of the culvert at its upstream and downstream ends and will be embedded approximately 5 to 10 feet below proposed finished grades.

We understand that North Street will be repaved as part of the project and that roadway grade changes will be negligible. We understand, however, that raises in grade (RIG) of up to about 8 or 9 feet are planned at the proposed retaining wall areas, at the upstream and downstream ends of the proposed culvert.

SUBSURFACE EXPLORATION PROGRAM

Subsurface explorations at the site include borings performed on behalf of O'Reilly, Talbot, and Okun Associates, Inc. (OTO) as part of their initial geotechnical evaluation in 2020 and the recent borings performed for this evaluation. Approximate locations of the previous and recent borings are shown on **Figure 2**.

PREVIOUS (2020) BORINGS

Two borings (designated as Nos. WB-1 and WB-2) were performed on November 12, 2020, as part of an initial geotechnical study by OTO on behalf of W&C for the proposed North Street culvert replacement design. The borings were each advanced to a maximum depth of 27 feet, corresponding to bottom of boring elevations of approximately 102 and 104 feet, and did not penetrate a silt and clay stratum encountered below the surficial fill layer.

The borings were performed using a truck rig from existing grades and advanced using hollow stem auger (HSA) techniques, with Standard Penetration Testing (SPT) and split spoon samples were obtained starting just below the bituminous asphalt pavement and at 5-foot-intervals thereafter. The SPT consisted of driving a 24-inch long, 1-3/8-inch ID split spoon sampler with a 140-pound automatic hammer falling 30 inches. The previous boring logs are included in **Appendix B**.

RECENT (2022) BORINGS

Three test borings (designated BB-01, BB-02, and BB-03) were completed by Seaboard Drilling, Inc. of Springfield, Massachusetts between December 28 and 30, 2022. The approximate locations of the borings are shown on **Figure 2**. The as-drilled boring locations are based on tape measurements from existing topographic on-site features and elevations interpolated from plans prepared by W&C. The locations and elevations should be considered accurate only to the degree implied by the methods used.

The borings were conducted using a truck-mounted drill rig. Boring BB-02 was initially advanced using hollow-stem-auger (HSA) drilling techniques through the surficial pavement and then each recent boring was advanced to completion using drive and wash cased and/or open-hole drilling techniques. SPTs and split spoon samples for borings BB-02 and BB-03 (performed proximate to previous borings WB-1 and WB-2) were limited within the top 13 feet with an initial sample within 1 foot of ground surface level and then were then obtained at approximate 5-foot intervals thereafter except for some instances at boring BB-03, where the sampling interval was increased up to 10 feet. SPT and split spoon samples for boring BB-01 were obtained continuously for the top 15 feet and then at approximate 5-foot intervals thereafter. The SPT consisted of driving a 24-inch-long, 1-3/8-inch-ID split spoon sampler with a 140-pound automatic hammer falling 30 inches. The number of blows to drive the sampler from 6 to 18 inches is the SPT blow count or N-value, a commonly used indicator of soil density and consistency. A 10-foot-long, NX-sized bedrock core was obtained in boring BB-01 while bedrock appeared to be encountered at borings BB-02 and BB-03 based on 3 to 4 feet of drill resistance and cuttings observed during advancement of a roller bit. The borings were backfilled with drill cuttings and at boring BB-02, performed within the street, the top approximately 1-foot of the borehole was patched with concrete to match the existing street grade.



A GZA representative observed the borings, classified soil samples using the Modified Burmister Soil Classification System and the rock cores using the International Society of Rock Mechanics System, and prepared the boring logs. The recent boring logs are included in **Appendix C**. Photographs of the rock core obtained from boring BB-01 are provided in **Appendix D**.

LABORATORY TESTING

PREVIOUS (2020) GEOTECHNICAL LABORATORY TESTING

Geotechnical laboratory testing was conducted on two composited soil samples from the top 5 feet of the previous borings. Geotechnical laboratory testing was performed by Allied Laboratories, Inc. of Springfield, Massachusetts, and included gradation analysis of the two samples by sieve method (ASTM D6913). Geotechnical laboratory test results are included in **Appendix E**.

RECENT (2023) GEOTECHNICAL LABORATORY TESTING

Two soil samples from the recent borings were submitted to Thielsch Laboratories in Cranston, Rhode Island, for sieve analyses to confirm field classifications, help develop soil properties across the site, and evaluate the potential for soil re-use. Additionally, 8 samples of fine-grained soil from the recent borings were submitted to GeoTesting Express of Acton, Massachusetts for natural water content and Atterberg Limit Testing to evaluate the water content and plasticity characteristics of the natural varved silt & clay to help establish engineering parameters for the soil using published empirical data. Geotechnical laboratory test results are included in **Appendix F**.

SUBSURFACE CONDITIONS

The soil and groundwater conditions discussed herein are primarily based on conditions observed in the recent borings and augmented with pertinent information from the previous borings. We note the ground surface elevations shown on the logs for previous borings WB-1 and WB-2 appear to be approximately 5.5 and 3.5 feet lower, respectively, than survey spot elevations at corresponding locations in the referenced Preliminary Design plans by W&C. For this report we have assumed the survey elevations on the W&C plans are correct.

A general description of the subsurface conditions encountered from the existing ground surface is summarized below. Refer to logs of the previous and recent borings in **Appendix B** and **Appendix C**, respectively, for more detailed descriptions of subsurface conditions at specific boring locations. A generalized subsurface profile along the approximate centerline of North Street and through the proposed culvert (Section A-A') is attached as **Figure 3**.

LOCAL GEOLOGY

Geologic information in the area of the site was obtained from the MassMapper online database and the USGS website. Based on the available geologic information, the subsurface conditions in the general area of the site consist of artificial fill and floodplain alluvium overlying sedimentary bedrock (Mesozoic Basin Province). The top of bedrock is mapped at a depth of 50 feet or less below existing ground surface (bgs).



GENERALIZED SUBSURFACE CONDITIONS

Subsurface conditions generally consist of fill overlying natural varved silt and clay, glacial till, and bedrock. Subsurface conditions between the borings are expected to vary.

Soil

Fill – Fill was encountered in the each of the previous and recent borings and ranged from about 11 to 16.5 feet in thickness.

The nature of the fill varied significantly across different portions of the site as follows:

At the south/central portions of the proposed culvert footprint (i.e., in previous borings WB-1 & WB-2 and recent borings BB-02 and BB-03), the fill consisted of very loose to very dense, red-brown to brown/tan, fine to coarse or fine to medium sand, with up to 50 percent gravel, and up to 35 percent silt. The SPT N-values ranged from 2 to 54 blows per foot (bpf). The higher SPT N-values were generally encountered in the first sample at or just below existing ground surface and below that, the SPT N-values were typically less than 9 bpf. Previous boring WB-2 encountered trace amounts of debris (asphalt and brick), while a piece of wood was observed in the fill in recent boring BB-02.

At the north/northwest portion of the proposed culvert (boring BB-01), the top 2 feet of the fill was generally consistent with the granular fill observed in other portions of the site, but below 2 feet bgs the fill consisted of medium stiff to stiff, dark gray to brown with occasional red, fine grained soil (ranging from clayey silt to clay and silt), with up to 20 percent fine sand, and occasional trace amounts of organic matter. The SPT N-values of the fill in this area ranged from 4 to 9 bpf.

Varved Silt & Clay – A varved silt & clay stratum, which appears to be part of the regional Connecticut Valley Varved Clay (CVVC) deposit, was encountered in each of the borings below the fill stratum at depths between approximately 11.5 and 16.5 feet bgs. The thickness of the CVVC ranged from approximately 19 feet at boring BB-01 at the north to 43 feet at boring BB-03 at the south (i.e. the CVVC becomes thicker from north to south). The stratum consisted of gray to brown or gray with red, soft to very stiff fine-grained soil (ranging from silt & clay to silty clay) with up to 10 percent fine sand. SPT N-values ranged from 2 to 16 bpf, but the vast majority of N values in the CVVC ranged from about 2 to 8 bpf.

Glacial Till – Glacial till was encountered in each recent boring below the CVVC stratum at depths between approximately 35.5 and 54.5 feet bgs. The thickness of the layer ranged from about 4.5 to 8 feet. The glacial till consisted of stiff to hard gray/brown/red-brown fine-grained soil (ranging from clayey silt to silty clay) with up to 50 percent fine to coarse sand, and up to 35 percent gravel. Only one SPT N-value of 21 bpf was obtained in boring BB-01, as the remaining samples typically overlapped with the CVVC stratum above or the bedrock below the glacial till.

Bedrock

Bedrock was encountered at each recent boring at depths ranging from 42.5 to 62.5 feet bgs, corresponding to approximate elevations of 70 to 94 feet. The top of, type, and quality of the bedrock was confirmed by coring 10 feet at boring BB-01. The top of bedrock was inferred at borings BB-02 and BB-03 based on the rate of penetration using a roller bit and the cuttings observed during advancement of the roller bit approximately 3 to 4 feet into the top of apparent bedrock. The top of bedrock elevation in the northern portion of the site was approximately 24 feet



higher than the top of bedrock encountered in the southern area of the site (i.e., the bedrock surface appears to be dipping from north to south).

Based on the rock coring at boring BB-01, the bedrock consists of hard, fresh to slightly weathered, brown-red, amorphous to fine-grained Siltstone with very thin, sub-horizontal bedding and moderately close to very close sub-horizontal to sub-vertical joints/fractures. Sample recovery of the two, 5-foot-long rock core runs were approximately 92 to 97 percent and Rock Quality Designation (RQD) values (the sum of all core pieces in a recovered core greater than 4 inches in length divided by the total length of core run) were 67 and 75 percent. Photographs of the rock cores are provided in **Appendix D**.

Groundwater

Based on observations of groundwater levels made during drilling of the previous borings, the water depths at the downstream and upstream boring locations were approximately 10 and 15 feet bgs, respectively, corresponding to elevations ranging from approximately 121.3 to 122.3 feet. We understand from W&C that based on their modeling results, the Base Flood Elevation (BFE, a floor having a one percent change of being met or exceeded in any given year) for the North Street Culvert area is 123.4.

The water level readings measured during drilling in the previous borings may not be stabilized readings and may not be representative of the actual groundwater level.

Note that fluctuations in groundwater levels will occur due to variations in season, precipitation, temperature, water level in White Brook, and other factors different from those existing at the time the measurements were made.

PRIMARY GEOTECHNICAL ISSUES

Based on the existing site conditions, proposed construction, and the subsurface conditions encountered in the explorations, we have identified the following geotechnical issues associated with the design and construction of the proposed culvert and retaining walls:

- Relatively thick layer of compressible fine-grained soil – A layer of compressible CVVC soil was observed across the site at approximately 11.5 to 16.5 feet bgs that extends to depths ranging from about 35.5 to 50 feet bgs and thicknesses varying from about 19 to 43 feet. These soils are susceptible to long-term consolidation settlement when subjected to sustained stress increases and have relatively low shear strength, requiring foundations to be designed for a relatively low bearing pressure.
- Potential for Differential Settlement – The foundation systems selected for the proposed culvert and retaining wall systems will need to limit the potential for differential settlement between the culvert and adjacent retaining wall sections to minimize separations between the structures and mitigate the potential for the raveling of backfill soils through gaps between arch segments that could potentially result from differential settlement.
- Relatively High Groundwater/Brook Water Level – Anticipated bottom of culvert excavation and bottom of retaining wall curtain panel elevations are anticipated to range from about 111.5 (north end) to 117 (south end). Observed groundwater and brook levels therefore appear to range from approximately 6 to 12 feet above the proposed bottom of culvert and retaining wall foundation/curtain panel elevations. Therefore, a combination of brook diversion and temporary cofferdams and construction dewatering are expected to



be required for construction of the new culvert foundations. Potential flood levels and flows must also be considered during design of the permanent structures and water control systems as the BFE at the Site is approximately 6.5 to 12 feet above the proposed bottom of culvert and retaining wall foundation/curtain panel elevations.

- Protection of Existing Utilities, Roadway, and Surrounding Areas During Construction – Temporary excavation support and/or utility support systems may be required to allow for OSHA-compliant excavation for demolition of the existing culvert and construction of the new culvert and retaining walls. The existing utilities that are not re-routed will need to be protected during construction.
- Reuse of On-Site Soils – Many of the soils excavated during construction are anticipated to contain a relatively high fines (silt and/or clay) content, generally do not meet the gradation requirements for use as structural backfill, and may be difficult to reuse as fill, especially in wet and/or cold conditions. Also, due to the lightweight backfill materials incorporated into the design, it appears that the majority of excavated materials will not be able to be reused as backfill and will require legal off-site disposal unless the material can be used to locally grade around the site.
- Existing Overhead Wires and Other Restrictions – Selection of equipment used to install the foundation for the proposed culvert and/or retaining walls will need to consider the presence of overhead utilities to provide adequate clearance. Construction may need to consider temporary utility outages. Selection of equipment will also need to consider wet subgrade conditions from working within the area of White Brook. There may be additional restrictions imposed from local environmental permits issued for this project.

GEOTECHNICAL DESIGN RECOMMENDATIONS

The following geotechnical recommendations for the proposed culvert and culvert headwalls/wingwalls are based on our evaluation of the available data and the design concepts provided to GZA. These recommendations are subject to the limitations contained in **Appendix A** and are based on foundation design provisions of the AASHTO LRFD Bridge Design Specifications, 9th Edition (2020 AASHTO LRFD), 2011 AASHTO Guide Specifications for LRFD Seismic Bridge Design, 2nd Edition, with 2015 Interim Revisions (2015 AASHTO LRFD Seismic), and the MassDOT LRFD Bridge Manual, 2020.

1. Foundations

The proposed culvert may be supported by either a reinforced structural mat foundation or deep foundations such as driven timber piles. However, based on our understanding of the project, it appears that the reinforced structural mat foundation will provide a simpler, easier to construct, and more cost-effective solution for support of the culvert, while still meeting Contech's required settlement criteria for the proposed arch culvert structure. Therefore, we have discounted the deep foundation option and recommendations for the structural mat foundation option are provided herein.

We understand the proposed wingwalls, which will consist of corrugated aluminum sheet panels, are relatively lightly loaded and will not require concrete foundations. The aluminum sheet panels may be supported by a minimum 6-inch-thick base-course of crushed stone, wrapped all-around by a layer of non-woven filter fabric.



Shallow Continuous Mat Foundation

The proposed culvert may be supported on a reinforced concrete mat foundation bearing on a minimum 12-inch-thick layer of ¾-inch Crushed Stone (MassDOT Material No. M2.01.4) base course, which in turn bears directly on the undisturbed CVVC layer. The mat foundation should be placed either: 1) no less than 2 feet below the scour elevation, or; 2) protected from scour.

Based on the assumed culvert invert elevations and boring information, it is expected that the bottom of the culvert foundation and underlying crushed stone base layer will be within the CVVC stratum. As a minimum, the bottom and sides of the Crushed Stone base course should be wrapped in non-woven geotextile fabric.

The recommended factored bearing resistance for the mat foundation (assumed 18-inches thick and 22-feet wide) supported on the Crushed Stone base course over the CVVC is 2 kips per square foot (ksf).

The factored bearing resistance is based on a resistance factor of 0.45 applied to the nominal bearing resistance in accordance with Table 10.5.5.2.2-1 of the AASHTO 2020 (refer to **Appendix G** for calculations).

Regarding frost protection, for the headwalls, wingwalls and portions of the culvert within 4 feet of the headwalls, the bottom of the crushed stone layer placed below the foundation should extend at least 4 feet below the finished exterior grade. For the portion of the culvert mat foundation greater than 4 feet from the headwalls, additional thickness of the crushed stone layer is not required since the outer edges of the culvert mat foundation will have approximately 12 to 20 feet of soil cover outside the culvert and with the 18-inch thick air-entrained concrete used to construct the mat foundation, the slab provides a sufficient thermal R value to insulate the ground below the mat slab from freezing due to potential below-freezing temperature air within the culvert.

2. Settlement

Based on the results of settlement analyses (see **Appendix G**), the estimated total and differential settlements for the proposed culvert mat foundation are up to approximately 1-1/2 and 3/4-inches, respectively, for the culvert mat foundation, provided the recommendations set forth herein are followed including the use of lightweight concrete for the mat foundation and lightweight fill over the culvert and in the adjacent raise-in-grade areas. Settlement is generally anticipated to be greatest in the areas of largest proposed raises-in-grade adjacent to the upstream and downstream ends of the proposed culvert.

The estimated settlements are anticipated to occur over a period of about 2 years after construction due to primary consolidation of the CVVC soils underlying the proposed culvert and adjacent fill areas. This settlement duration is based on a published value of 0.093 ft² per day for the coefficient of consolidation (c_v) for CVVC per Degroot and Lutenege (2003), and assumes a doubly drained CVVC layer. Although we estimate that installation of wick drains could significantly reduce the duration of the primary consolidation settlement, the added cost, duration, and complexity to incorporate wick drains into the construction does not appear to be warranted given that the magnitude of anticipated settlement appears to be tolerable for the proposed structure.

The estimated total and differential settlements above assume lightweight backfill and fill materials. The recommended vertical and lateral extents of lightweight materials are summarized in **Table B**. The parameters used in the settlement analyses are summarized in **Table C**.



Table B: Recommended Extents of Lightweight Fill/Backfill Materials

Area	Vertical Extent	Lateral Extent
Upstream & Downstream of Culvert	From existing subgrade to proposed bottom of topsoil	Entire raise-in-grade (RIG) area contained within headwalls and wingwalls
Culvert Area	From bottom of foundation mat slab to proposed bottom of pavement base course/bottom of topsoil	Within a 1V:2H zone extending upwards from one foot outside bottom edge of mat slab to bottom of proposed pavement base course/topsoil

Table C - Construction Materials and Material Use Assumptions for Settlement Analysis

Material Description	Assumed Unit Weight (pcf)	Assumed Use
Reinforced Lightweight Concrete	100	Culvert mat foundation
ES-LWA	70	Use as a non-buoyant lightweight fill from the bottom of proposed culvert and headwall/retaining wall grades to the greater of: 1-foot above the proposed culvert and the BFE of 123.4.
UL-FGA	25	Use from the top of the ES-LWA to 1 and 1.5 feet below proposed finished grades in proposed landscaped and paved areas, respectively

Refer to **Appendix H** for manufacturer literature for the ES-LWA and UL-FGA materials, respectively. In GZA’s opinion, the unit weight values for lightweight fills recommended herein for design represent conservative values of in-place materials following densification and are based on our prior experience on other projects.

3. Lateral Earth Pressure

We understand that Contech will determine the lateral earth pressures on the culvert arch structure and will design the wingwalls and headwalls, including the selection of lateral earth pressures, in accordance with the MassDOT Bridge Manual Section 3.1.6. The following fill/backfill parameters/assumptions are recommended for evaluation of lateral earth pressures:

- Estimated backfill soil (internal) friction angle (ϕ) of 34¹ degrees for normal-weight fill and 38 degrees (conservative in-place value) for expanded shale lightweight aggregate (ES-LWA) and ultralightweight foamed glass aggregate (UL-FGA) fills;

¹ Estimated backfill soil (internal) friction angle (ϕ) of 37 degrees may be used for normal-weight fill where the backfill meets the gradation requirements of MassDOT Gravel Borrow (material M.1.03.0).



- A moist soil unit weight of 125 pounds per cubic foot (pcf) for normal weight fill, 70 pcf for ES-LWA, and 25 pcf for UL-FGA;
- Backfill slopes behind the walls matching the grading design by W&C (i.e. up to 2H:1V and 4H:1V slopes behind the proposed downstream and upstream headwalls/wingwalls, respectively);
- Wall friction angle of 17 degrees for ES-LWA and UL-FGA fills in accordance with AASHTO Table C3.11.5.3.1 for single-size hard rock fill against steel sheet piles;
- No groundwater influence (assumes water is relieved through weep holes and free-draining material (i.e. Gravel Borrow or open-graded ES-LWA or UL-FGA fills) is utilized behind retaining walls for a lateral distance of at least 3 feet).

Where the calculated earth pressure behind the below grade walls is less than 250 pounds per square foot (psf), it should be increased to approximately 250 psf to account for stresses created by compaction of fill behind the culvert wall. Additional lateral pressures due to vehicular traffic/equipment surcharge and seismic loads where applicable should be applied as required by AASHTO 2020. When considering fill in front of the wall, its passive resistance should be neglected in determining wall stability in accordance with the MassDOT LRFD Bridge Manual.

These recommended pressures assume that the below grade walls are backfilled with free draining material and equipped with properly designed drains and/or weepholes such that the water level outside of the culvert is not higher than the water level in the culvert. Alternatively, the below grade walls should be designed for lateral pressures assuming the effective unit weight of soil plus hydrostatic pressure, and applicable lateral surcharge pressure.

4. Geotechnical Seismic Design Recommendations

Seismic Site Class

Based on the subsurface conditions at the site and the SPT N-values encountered within the soil profile, we recommend the site be considered Site Class E in accordance with Article 3.4.2.2 of MassDOT LRFD and the 2011 AASHTO LRFD Seismic Guide Specification Table 3.4.2.1-1. Refer to **Appendix G** for the seismic Site Class analysis.

Seismic Design Parameters

Based on 2020 MassDOT LRFD Section 3.1.2, North Street is not on or over a National Highway System (NHS) route, is not designated as an “other route,” and we understand that it is not a designated emergency evacuation route. Therefore, the culvert/bridge can be classified as a non-critical/non-essential bridge. In accordance with 2020 MassDOT LRFD Section 3.4.2.1, the seismic hazard maps provided in the 2011 AASHTO LRFD Seismic should be used to develop seismic design parameters that correspond to the 1,000-year return period.

Using the 1,000-year return period seismic hazard maps (corrected for Site Class E in accordance with Section 3.4.1 of 2011 AASHTO LRFD Seismic), we recommend the design response spectra for the bridge be constructed using the parameters in **Table D**.



Table D: Seismic Design Parameters

PGA (g)	A _s (g)	S _s (g)	S ₁ (g)	S _{Ds} (g)	S _{D1} (g)
0.059	0.148	0.13	0.038	0.326	0.132

where:

- A_s is the response spectral acceleration based on Site Class E.
- S_s is the short period spectral response acceleration coefficient.
- S₁ is the long period spectral response acceleration coefficient.
- S_{Ds} is the design spectral acceleration coefficient at 0.2-second period.
- S_{D1} is the design spectral acceleration coefficient at 1.0-second period.

In accordance with Table 3.5-1 of the 2011 AASHTO Guide Specifications for LRFD Seismic Bridge Design, and based on an S_{D1} < 0.15, the Seismic Design Category (SDC) for the site is SDC A.

Refer to **Appendix G** for a summary of the recommended seismic design parameters.

Liquefaction

Per the 2011 AASHTO Guide Specifications for LRFD Seismic Bridge Design, a liquefaction analysis is not required for bridges in SDC A. However, the culvert foundation soils are judged not to be susceptible to liquefaction.

5. Design Groundwater Elevation

Based on information provided by W&C, the 100-year Base Flood Elevation (BFE) at the Site is El. 123.4.

6. Permanent Groundwater Control

Groundwater and the BFE at the site are generally high relative to the proposed bottom of culvert foundation and wingwall excavations (approximately 3.5 to 11 feet above the anticipated bottom elevations), and it is anticipated that the proposed culvert mat foundation will need to be designed by the structural engineer to ensure adequate resistance against hydrostatic uplift.

Additionally, the potential for uplift of the proposed culvert, particularly at the downstream portion of the proposed culvert, should be evaluated by the project structural engineer to determine if uplift resistance is required in this area. These uplift resisting measures may include such options as anchoring the culvert structure to deadmen and/or helical piles.

7. Utilities

New and existing utilities to remain in the area of the proposed culvert construction should be protected from the potential effects of settlement. These measures may include new or retrofitted oversized sleeves to allow for differential settlements between the areas within and outside of the proposed construction, and/or consideration post-construction settlement monitoring for sensitive utilities, if warranted. Also, the civil engineer should consider the potential settlements of utilities at planned manhole connections.



CONSTRUCTION CONSIDERATIONS

1. Subgrade Preparation

Based on the boring data and estimated bottom of mat foundation and wingwall elevations ranging from approximately 111.5 to 118, we anticipate that the natural CVVC stratum will be present at the bottom of foundation and wingwall grades. We recommend that the Contractor excavate to at least 12 inches below the bottom of foundation. At least 12 inches of ¾-inch Crushed Stone, wrapped in non-woven filter fabric, should be placed to serve as a foundation base course and help protect the subgrades from disturbance.

Disturbed footing subgrades and/or loose or soft zones should be over excavated to remove loose/disturbed material and replaced with compacted ¾-inch Crushed Stone wrapped in non-woven geotextile filter fabric. If existing Fill soil is encountered at the bottom of foundation, it must over-excavated and backfilled to culvert subgrade with ¾-inch Crushed Stone wrapped in non-woven geotextile filter fabric within the zone of influence (defined as 1 foot laterally from bottom edge of footing and then sloping down at 1 horizontal to 1 vertical).

Based on the borings, soils at the bottom of excavation will be susceptible to disturbance during excavation in wet conditions. Excavations should be sequenced and conducted in such a way as to minimize disturbance of subgrades and final excavation to the undisturbed natural CVVC subgrades should be with a smooth-edged excavator bucket. Equipment should not operate directly on the natural subgrade to limit disturbance and care should be taken to avoid excess traffic on the prepared subgrades prior to placement of concrete foundations and backfill material. The exposed soil subgrade should be adequately dewatered, protected against precipitation and the subgrade should not be allowed to freeze.

2. Groundwater and Surface Water Control

The contractor should be prepared to manage and control/divert the brook flow and groundwater during foundation excavation and culvert and wingwall construction, as well as control surface water from entering excavations in order to provide a dry and stable subgrade. The method of dewatering excavations will depend on several factors, including depth of excavation, localized soil conditions encountered, time of year performed, size of the open excavation and the length of time the excavation is left open.

The contractor should be responsible for selecting dewatering methods based on their proposed methods and equipment used for excavation to achieve the desired objectives (that is, maintaining a dry condition at the bottom of the excavation during installation of structures, preparation of stable subgrades, etc.). In addition to diverting brook flow and/or constructing cofferdams to construct the foundations, we anticipate that multiple sump pumps will be required to control water during foundation construction. If utilized, local sump pumps should be surrounded by ¾-inch Crushed Stone wrapped in non-woven filter fabric to limit migration of fines. Excavation below the groundwater level may not immediately be evident due to the relatively low permeability of the CVVC, but over time seepage may become visible on excavation side slopes and/or the side slopes may become unstable and slough. Additionally, the contractor's construction methods will need to include measures for temporary diversion of the brook flow to accommodate construction.

Dewatering efforts must satisfy requirements of local, state and federal environmental and conservation authorities.



3. Temporary Excavation/Utility Support

We anticipate during excavation for the proposed culvert that temporary support of excavation and/or utilities systems will likely be implemented to protect existing facilities to remain, limit excavation quantities and/or to help with groundwater control. Temporary excavation/utility support systems should be designed using the soil properties in **Table E**:

Table E – Recommended Soil Properties for Temporary Excavation/Utility Support

Layer	Minimum Total Unit Weight (pcf)	Undrained Shear Strength (psf)	Maximum Friction Angle Φ (degrees)
Existing Fill	120	-	30
CVVC	118	500	-

Groundwater pressure and applicable surcharge pressures should be considered where applicable in the excavation support design.

Temporary earth/utility support systems should be selected by the contractor and designed by an experienced Professional Engineer registered in the Commonwealth of Massachusetts and retained by the contractor. Where excavation sides are unsupported, and/or cut back and sloped, they should be in accordance with Occupational Safety and Health Administration (OSHA) Construction Industry Standards.

Earth/utility support system elements installed below bottom of culvert foundation and retaining walls should be left in place. Steel elements of the support systems may be left in place above bottom of footing, provided they are cut off at least 5 feet below roadway grade. If used, all timber should be removed and replaced with approved compacted Structural Fill or Controlled Density Fill (MassDOT M.4.08.0) in confined areas when removing the earth support system. Timber components of support systems should not be utilized in locations where their removal could jeopardize the stability of the culvert, retaining walls, utilities, or other facilities to remain.

4. Backfill and Compaction

Backfill against and behind the below-grade culvert and wingwalls should consist of free-draining ES-LWA and UL-FGA fills below and above the BFE, respectively as described herein. Structural fill placed below the proposed culvert foundation, retaining walls, and roadway should be in accordance with Sections 150 and M of MassDOT Standard Specifications for Highways and Bridges. We understand the project civil engineer (W&C) is performing design of the proposed pavement section. Backfill material below the culvert foundation and headwalls/wingwalls should be in accordance with the following table.



Table F: Backfill Material Specification & Recommended Use

Borrow Material	MassDOT Spec. No.	Use
Crushed Stone	M2.01.1	Culvert, Headwall and Wingwall base course layer

Crushed Stone should be placed in lifts no greater than 12-inches-thick with each lift compacted to an unyielding surface. Crushed Stone placed in layers greater than 4 inches should be wrapped all-around in non-woven geotextile fabric. Fill should be free of frost and not be placed over frozen soil. Subgrades should be protected against frost during and after construction.

Extra care should be used when compacting adjacent to walls. Only hand-operated rollers or plate compactors weighing not more than 250 pounds should be used within a lateral distance of 5 feet of the back of a culvert wall or wingwall. Backfill and compact all fills at approximately similar elevations on each side of the culvert structure to avoid unbalanced loading.

Lightweight Aggregate Fill Placement

Typical ES-LWA fill consists of expanded shale aggregate, which is commercially available from specialty suppliers, many of which are located in New York State. It has a unit weight of about 65 to 70 pounds per cubic foot (pcf) and has an open-graded particle size distribution with a typical 3/8-inch to 3/4-inch maximum particle size. Accordingly, this lightweight fill can be placed in a manner similar to crushed stone with a filter fabric wrap to prevent migration of fine soil particles into the void space. Other gradations may be available, but may have unit weights that vary from that recommended herein for design. ES-LWA should be compacted with lightweight compaction equipment (for example, vibratory plate compactors) since heavy rollers may crush the material.

Typical UL-FGA fill consists of processed recycled glass combined with a foaming agent, which is commercially available from a specialty supplier located in Pennsylvania. UL-FGA should be placed in loose lifts not exceeding 24 inches or as required by the manufacturer; whichever is less. Each lift shall be uniformly distributed and compacted with at least two passes and a maximum of four passes of hand-operated vibratory compaction equipment until the lightweight fill appears stable during compaction. Excessive compaction should be avoided to minimize crushing of the aggregate. Use compaction equipment recommended by the aggregate manufacturer.

5. Reuse of Excavated Materials

Based on the soil descriptions in the boring logs, the compressibility of the existing natural CVVC stratum underlying the fill, and the importance of limiting differential settlement between the culvert headwalls and wingwalls, the existing fill and excavated CVVC should not be used as backfill behind the proposed wingwalls and headwalls or over the proposed culvert to reduce proposed total and differential settlements. Excavated soil that cannot be reused in these areas should be regraded elsewhere on site as specified by the civil engineer and as permitted by local environmental permits or removed from the site and disposed in accordance with applicable local, state and federal regulations.



FINAL DESIGN AND CONSTRUCTION SERVICES

We trust that the information presented herein is sufficient for your use. A supplemental memorandum with recommendations for the subgrade modulus for design of the mat foundation will be provided under separate cover.

During construction, we recommend that GZA be engaged to assist with submittal reviews, as well as perform construction observation and testing services during the earthwork and foundation construction phases of the project, where we would observe the contractor's activities for compliance with recommendations in our geotechnical report and the contract documents.

CLOSING

We appreciate the opportunity to work with you on this project and look forward to receipt of any questions or comments you may have.

Very truly yours,
GZA GEOENVIRONMENTAL, INC.

Michael Ostrowski, E.I.T.
Project Manager



Terese M. Kwiatkowski, P.E.
Consultant/Reviewer

Martin A. Rodick, P.E.
Principal-in-Charge

Attachments: Figures
Appendix A – Limitations
Appendix B – Previous (2020) Test Boring Logs by Others
Appendix C – Recent (2022) Test Boring Logs by GZA
Appendix D – 2022 Rock Core Photographs
Appendix E – Previous (2020) Geotechnical Laboratory Test Results by Others
Appendix F – Recent (2022) Geotechnical Laboratory Test Results
Appendix G – Calculations
Appendix H – Lightweight Fill Product Information

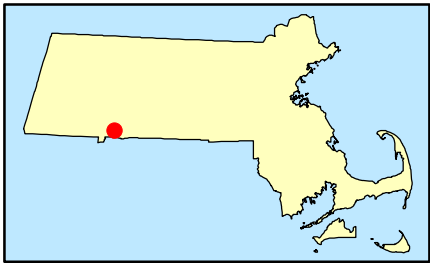
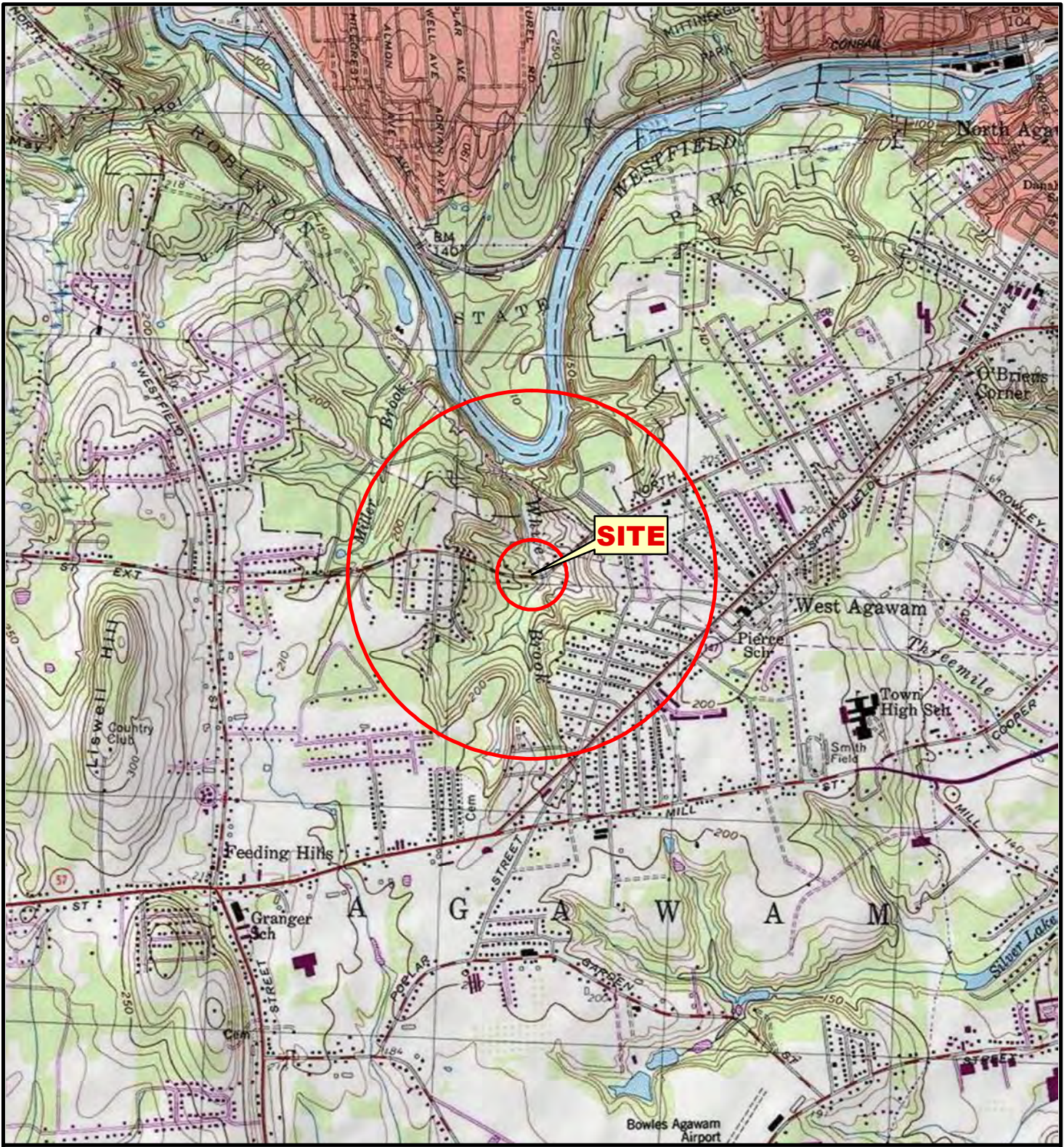

FIGURES



SOURCE : USGS TOPOGRAPHIC QUADRANGLES SCANNED BY THE NATIONAL GEOGRAPHIC SOCIETY & I-CUBED, COPYRIGHT 2011

Data Supplied by :



PROJ. MGR.: MJO
DESIGNED BY: MJO
REVIEWED BY: MAR
OPERATOR: MJO
DATE: 01-05-2023



LOCUS MAP
SHOWING 500 FOOT & 1/2 MILE OFFSETS
GEOTECHNICAL EVALUATION
NORTH STREET OVER WHITE BROOK
AGAWAM, MASSACHUSETTS

JOB NO.
01.0177018.00
FIGURE NO.
1

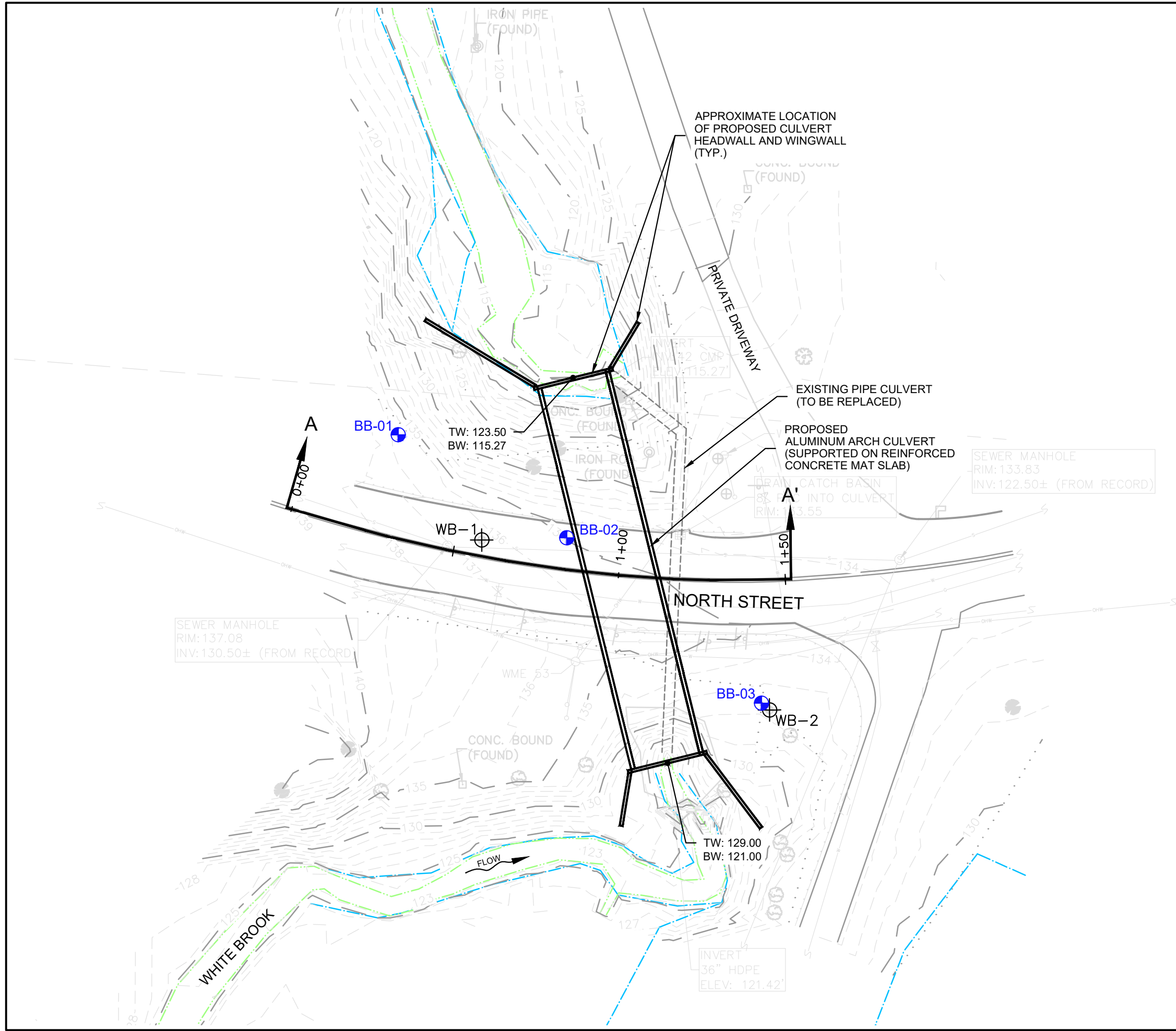
© 2023 - GZA GeoEnvironmental, Inc.
 GZA-J170.000-179.999\177018\177018-00.MXD\Figures\CAD\01_017718.00 - North Street_White Brook.dwg [FIGURE 2] April 11, 2023 - 7:39am michael.ostrowski



LEGEND:

-  **BB-01** TEST BORING PERFORMED BY SEABOARD DRILLING, INC. OF SPRINGFIELD, MASSACHUSETTS ON DECEMBER 28 TO 30, 2022. OBSERVED AND LOGGED BY GZA PERSONNEL
-  **WB-2** BORING PERFORMED BY SEABOARD DRILLING, INC. OF SPRINGFIELD, MASSACHUSETTS ON NOVEMBER 12, 2020. OBSERVED AND LOGGED BY O'REILLY, TALBOT & OKUN ASSOCIATES, INC. (OTO).
-  **A A'** SUBSURFACE PROFILE ALIGNMENT (SEE FIGURE 3)

NOTES:

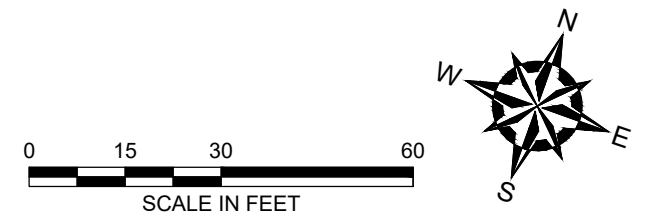

1. BASE MAP DEVELOPED FROM AN AUTOCAD DRAWING FILE PREPARED BY WOODARD & CURRAN ENTITLED "190299K_NORTH STREET", TRANSMITTED TO GZA ON JANUARY 10, 2023.
2. PROPOSED FEATURES WERE APPROXIMATED FROM ELECTRONIC IMAGE FILE "NORTH STREET 60% DESIGN DRAWINGS" OF DRAWING C-102, SHEET 5 OF 8, TITLED SITE LAYOUT PLAN, PREPARED BY WOODARD & CURRAN, ORIGINAL SCALE 1"=20', DATED OCTOBER, 2022, AND TRANSMITTED TO GZA ON OCTOBER 28, 2022.
3. THE HORIZONTAL DATUM IS REFERENCED TO THE NORTH AMERICAN DATUM OF 1983 (NAD83). EXPLORATION GROUND SURFACE ELEVATIONS ARE REFERENCED TO THE NORTH AMERICAN VERTICAL DATUM OF 1988 (NAVD88).
4. THE BB-SERIES EXPLORATION LOCATIONS ARE BASED ON TAPED MEASUREMENTS AND/OR LINE OF SIGHT FROM EXISTING SITE FEATURES. THE DATA SHOULD BE CONSIDERED ACCURATE ONLY TO THE DEGREE IMPLIED BY THE METHOD USED. BORING LOCATIONS SHOWN HEREIN SHOULD BE CONSIDERED APPROXIMATE.
5. THE WB-SERIES EXPLORATION LOCATIONS WERE OBTAINED FROM THE BASE MAP FILE REFERENCED IN NOTE #1.



UNLESS SPECIFICALLY STATED BY WRITTEN AGREEMENT, THIS DRAWING IS THE SOLE PROPERTY OF GZA GEOENVIRONMENTAL, INC. (GZA). THE INFORMATION SHOWN ON THE DRAWING IS SOLELY FOR USE BY GZA'S CLIENT OR THE CLIENT'S DESIGNATED REPRESENTATIVE FOR THE SPECIFIC PROJECT AND LOCATION IDENTIFIED ON THE DRAWING. THE DRAWING SHALL NOT BE TRANSFERRED, REUSED, COPIED, OR ALTERED IN ANY MANNER FOR USE AT ANY OTHER LOCATION OR FOR ANY OTHER PURPOSE WITHOUT THE PRIOR WRITTEN CONSENT OF GZA. ANY TRANSFER, REUSE, OR MODIFICATION TO THE DRAWING BY THE CLIENT OR OTHERS, WITHOUT THE PRIOR WRITTEN EXPRESS CONSENT OF GZA, WILL BE AT THE USER'S SOLE RISK AND WITHOUT ANY RISK OR LIABILITY TO GZA.

**PROPOSED CULVERT REPLACEMENT
 NORTH STREET OVER WHITE BROOK
 AGAWAM, MASSACHUSETTS**

EXPLORATION LOCATION PLAN

PREPARED BY:  GZA GeoEnvironmental, Inc. Engineers and Scientists www.gza.com		PREPARED FOR:  Woodard & Curran	
PROJ MGR: MJO	REVIEWED BY: MAR	CHECKED BY: TMK	FIGURE
DESIGNED BY: MJO	DRAWN BY: AJP	SCALE: AS SHOWN	2
DATE: APRIL 2023	PROJECT NO. 01.0177018.00	REVISION NO. 0	

© 2023 - GZA GeoEnvironmental, Inc. GZA-J170.000-179.999/177018177018-00.MXD\Figures\CAD\01.017718.00 - North Street.dwg [FIGURE 3] April 11, 2023 - 7:49am michael.ostrowski

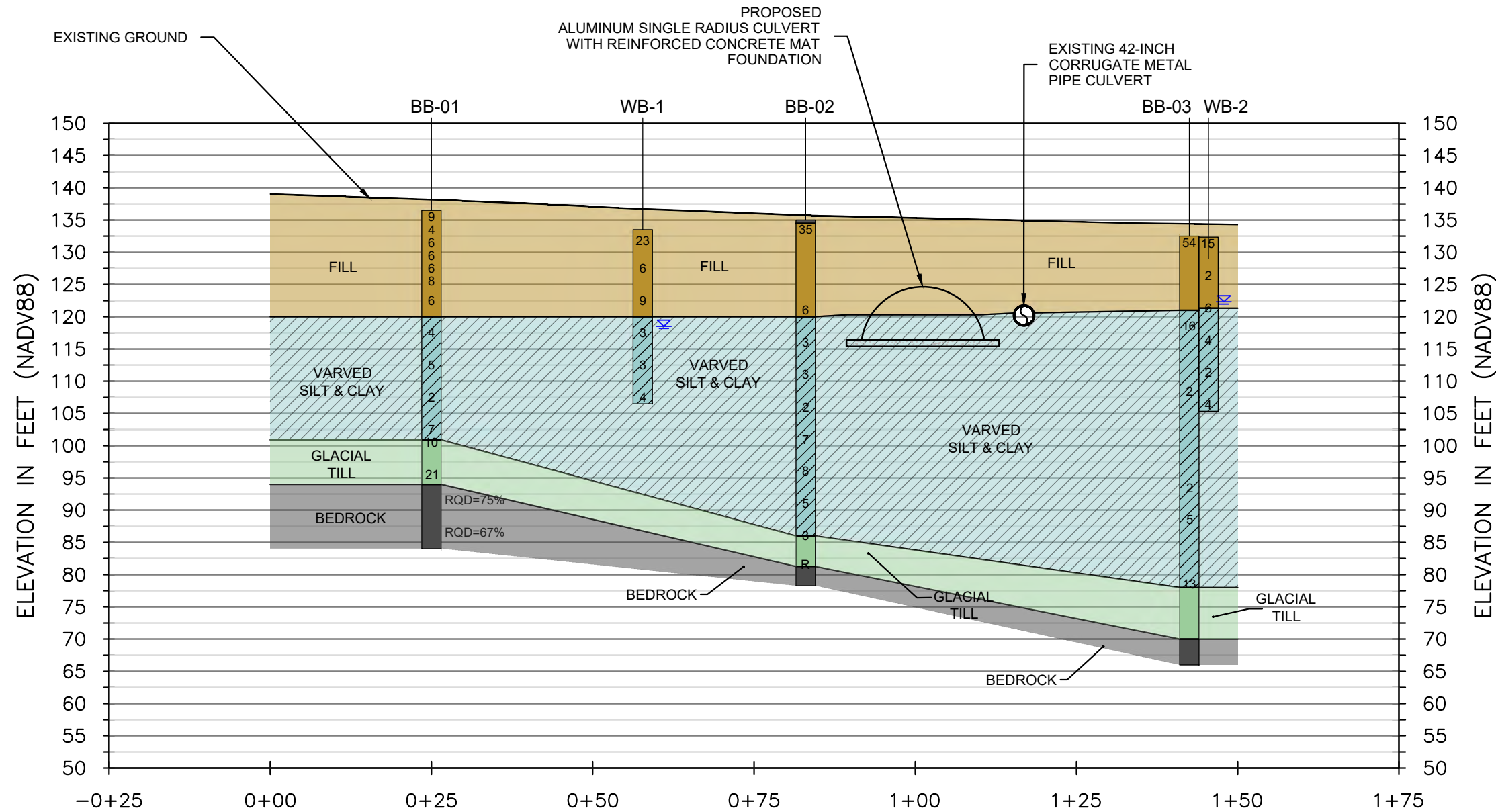

LEGEND:

- SOIL TYPE ENCOUNTERED IN BOREHOLE
- INDICATES APPROXIMATE INTERPOLATED STRATUM
- FILL
- VARVED SILT & CLAY
- GLACIAL TILL
- BEDROCK

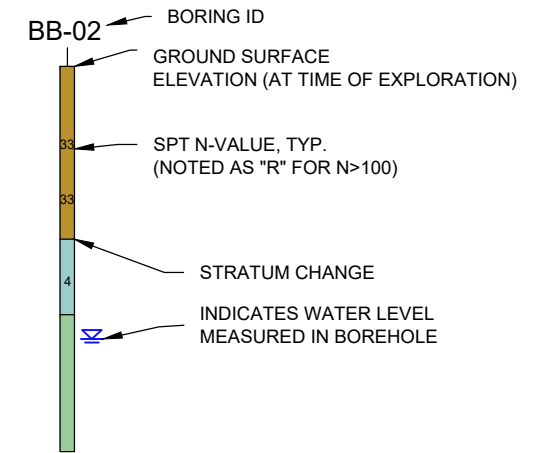

PROFILE A-A'

NOTES:

1. EXISTING & PROPOSED GROUND SURFACE ELEVATIONS OBTAINED FROM AN AUTOCAD DRAWING FILE PREPARED BY WOODARD & CURRAN ENTITLED "190299K_NORTH STREET", TRANSMITTED TO GZA ON JANUARY 10, 2023.
2. REFER TO FIGURE 2 FOR THE LOCATION OF THE SUBSURFACE PROFILE AND REFERENCE INFORMATION REGARDING THE SUBSURFACE EXPLORATIONS.
3. EXISTING CULVERT LOCATION WAS APPROXIMATED FROM THE ELECTRONIC IMAGE FILE "NORTH STREET 60% DESIGN DRAWINGS" OF DRAWING C-102, SHEET 5 OF 8, TITLED SITE LAYOUT PLAN, PREPARED BY WOODARD & CURRAN, ORIGINAL SCALE 1"=20', DATED OCTOBER, 2022, AND TRANSMITTED TO GZA ON OCTOBER 28, 2022.
4. PROPOSED CULVERT LOCATION, DIMENSIONS, AND INVERT ELEVATION ESTIMATED BASED ON A PDF VERSION OF A PLAN PREPARED BY WOODARD & CURRAN ENTITLED "SITE LAYOUT PLAN," DATED 2/16/2023.
5. PROPOSED MAT FOUNDATION BASED ON GEOTECHNICAL EVALUATION PREPARED BY GZA AND APPROVED BASED ON DISCUSSIONS WITH CONTECH ENGINEERED SOLUTIONS, LLC
6. THE STRATIFICATION LINES SHOWN ON THE SUBSURFACE PROFILE REPRESENT GZA'S INTERPRETATIONS OF THE SUBSURFACE CONDITIONS INDICATED ON THE BORING LOGS AND ARE APPROXIMATE BETWEEN SUBSURFACE CONDITIONS. ACTUAL TRANSITIONS WILL VARY FROM THOSE SHOWN.
7. REFER TO THE BORING LOGS FOR DETAILED INFORMATION ON GROUND SURFACE ELEVATION, GROUNDWATER, INTERLAYER STRATIGRAPHY AND ADDITIONAL SUBSURFACE INFORMATION. FLUCTUATIONS IN GROUNDWATER LEVELS MAY OCCUR DUE TO VARIATION IN SEASON, RAINFALL, SITE FEATURES, AND OTHER FACTORS DIFFERENT FROM THOSE AT THE TIME OF THE MEASUREMENTS.
8. EXPLORATION GROUND SURFACE ELEVATIONS ARE REFERENCED TO THE NORTH AMERICAN VERTICAL DATUM OF 1988 (NAVD88). THE WB-SERIES EXPLORATION GROUND SURFACE ELEVATIONS WERE OBTAINED FROM THE AUTOCAD DRAWING FILE REFERENCED IN NOTE #1.
9. THE BB-SERIES EXPLORATION LOCATIONS ARE BASED ON TAPED MEASUREMENTS AND/OR LINE OF SIGHT FROM EXISTING SITE FEATURES. THE DATA SHOULD BE CONSIDERED ACCURATE ONLY TO THE DEGREE IMPLIED BY THE METHOD USED. BORING LOCATIONS SHOWN HEREIN SHOULD BE CONSIDERED APPROXIMATE.

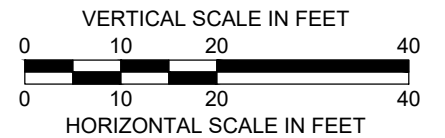

UNLESS SPECIFICALLY STATED BY WRITTEN AGREEMENT, THIS DRAWING IS THE SOLE PROPERTY OF GZA GEOENVIRONMENTAL, INC. (GZA). THE INFORMATION SHOWN ON THE DRAWING IS SOLELY FOR USE BY GZA'S CLIENT OR THE CLIENT'S DESIGNATED REPRESENTATIVE FOR THE SPECIFIC PROJECT AND LOCATION IDENTIFIED ON THE DRAWING. THE DRAWING SHALL NOT BE TRANSFERRED, REUSED, COPIED, OR ALTERED IN ANY MANNER FOR USE AT ANY OTHER LOCATION OR FOR ANY OTHER PURPOSE WITHOUT THE PRIOR WRITTEN CONSENT OF GZA. ANY TRANSFER, REUSE, OR MODIFICATION TO THE DRAWING BY THE CLIENT OR OTHERS, WITHOUT THE PRIOR WRITTEN EXPRESS CONSENT OF GZA, WILL BE AT THE USER'S SOLE RISK AND WITHOUT ANY RISK OR LIABILITY TO GZA.

**PROPOSED CULVERT REPLACEMENT
NORTH STREET OVER WHITE BROOK
AGAWAM, MASSACHUSETTS**

SUBSURFACE PROFILE

PREPARED BY: GZA GeoEnvironmental, Inc. Engineers and Scientists www.gza.com		PREPARED FOR: Woodard & Curran	
PROJ MGR: MJO	REVIEWED BY: MAR	CHECKED BY: TMK	FIGURE
DESIGNED BY: MJO	DRAWN BY: AJP/MJO	SCALE: AS SHOWN	3
DATE: APRIL 2023	PROJECT NO. 01.0177018.00	REVISION NO. 0	



APPENDIX A – LIMITATIONS



USE OF REPORT

1. GZA GeoEnvironmental, Inc. (GZA) prepared this report on behalf of, and for the exclusive use of our Client for the stated purpose(s) and location(s) identified in the Proposal for Services and/or Report. Use of this report, in whole or in part, at other locations, or for other purposes, may lead to inappropriate conclusions; and we do not accept any responsibility for the consequences of such use(s). Further, reliance by any party not expressly identified in the contract documents, for any use, without our prior written permission, shall be at that party's sole risk, and without any liability to GZA.

STANDARD OF CARE

2. GZA's findings and conclusions are based on the work conducted as part of the Scope of Services set forth in Proposal for Services and/or Report, and reflect our professional judgment. These findings and conclusions must be considered not as scientific or engineering certainties, but rather as our professional opinions concerning the limited data gathered during the course of our work. If conditions other than those described in this report are found at the subject location(s), or the design has been altered in any way, GZA shall be so notified and afforded the opportunity to revise the report, as appropriate, to reflect the unanticipated changed conditions .
3. GZA's services were performed using the degree of skill and care ordinarily exercised by qualified professionals performing the same type of services, at the same time, under similar conditions, at the same or a similar property. No warranty, expressed or implied, is made.
4. In conducting our work, GZA relied upon certain information made available by public agencies, Client and/or others. GZA did not attempt to independently verify the accuracy or completeness of that information. Inconsistencies in this information which we have noted, if any, are discussed in the Report.

SUBSURFACE CONDITIONS

5. The generalized soil profile(s) provided in our Report are based on widely-spaced subsurface explorations and are intended only to convey trends in subsurface conditions. The boundaries between strata are approximate and idealized, and were based on our assessment of subsurface conditions. The composition of strata, and the transitions between strata, may be more variable and more complex than indicated. For more specific information on soil conditions at a specific location refer to the exploration logs. The nature and extent of variations between these explorations may not become evident until further exploration or construction. If variations or other latent conditions then become evident, it will be necessary to reevaluate the conclusions and recommendations of this report.
6. In preparing this report, GZA relied on certain information provided by the Client, state and local officials, and other parties referenced therein which were made available to GZA at the time of our evaluation. GZA did not attempt to independently verify the accuracy or completeness of all information reviewed or received during the course of this evaluation.
7. Water level readings have been made in test holes (as described in this Report) and monitoring wells at the specified times and under the stated conditions. These data have been reviewed and interpretations have been made in this Report. Fluctuations in the level of the groundwater however occur due to temporal or spatial variations in areal recharge rates, soil heterogeneities, the presence of subsurface utilities, and/or natural or artificially induced perturbations. The water table encountered in the course of the work may differ from that indicated in the Report.
8. GZA's services did not include an assessment of the presence of oil or hazardous materials at the property. Consequently, we did not consider the potential impacts (if any) that contaminants in soil or groundwater may have on construction activities, or the use of structures on the property.



9. Recommendations for foundation drainage, waterproofing, and moisture control address the conventional geotechnical engineering aspects of seepage control. These recommendations may not preclude an environment that allows the infestation of mold or other biological pollutants.

COMPLIANCE WITH CODES AND REGULATIONS

10. We used reasonable care in identifying and interpreting applicable codes and regulations. These codes and regulations are subject to various, and possibly contradictory, interpretations. Compliance with codes and regulations by other parties is beyond our control.

ADDITIONAL SERVICES

11. GZA recommends that we be retained to provide services during any future: site observations, design, implementation activities, construction and/or property development/redevelopment. This will allow us the opportunity to: i) observe conditions and compliance with our design concepts and opinions; ii) allow for changes in the event that conditions are other than anticipated; iii) provide modifications to our design; and iv) assess the consequences of changes in technologies and/or regulations.



APPENDIX B – PREVIOUS (2020) BORING LOGS BY OTHERS

BORING LOGS

SUMMARY OF THE BURMISTER SOIL CLASSIFICATION SYSTEM (MODIFIED)

RELATIVE DENSITY (of non-plastic soils) OR CONSISTENCY (of plastic soils)

STANDARD PENETRATION TEST (SPT)
Method: Samples were collected in accordance with ASTM D1586, using a 2" diameter split spoon sampler driven 24 inches. If samples were collected using direct push methodology (Geoprobe), SPTs were not performed and relative density/consistency were not reported. N-Value: The number of blows with a 140 lb. hammer required to drive the sampler the middle 12 inches. WOR: Weight Of Rod (depth dependent) WOH: Weight Of Hammer (140 lbs.)

COHESIONLESS SOILS		COHESIVE SOILS	
BLOWS/FOOT (SPT N-Value)	RELATIVE DENSITY	BLOWS/FOOT (SPT N-Value)	CONSISTENCY
0-4	Very loose	<2	Very soft
4-10	Loose	2-4	Soft
10-30	Medium dense	4-8	Medium Stiff
30-50	Dense	8-15	Stiff
>50	Very dense	15-30	Very stiff
*Based upon uncorrected field N-values		>30	Hard

MATERIAL: (major constituent identified in CAPITAL letters)

COHESIONLESS SOILS		
MATERIAL	FRACTION	GRAIN SIZE RANGE
GRAVEL	Coarse	3/4" to 3"
	Fine	1/4" to 3/4"
SAND	Coarse	1/16" to 1/4"
	Medium	1/64" to 1/16"
	Fine	Finest visible & distinguishable particles
SILT/CLAY	see adjacent table	Cannot distinguish individual particles
COBBLES	3" to 6" in diameter	
BOULDERS	> 6" in diameter	

Note: Boulders and cobbles are observed in test pits and/or auger cuttings.

COHESIVE SOILS		
SMALLEST DIAMETER	PLASTICITY	IDENTITY
None	Non-plastic	SILT
1/4" (pencil)	Slight	Clayey SILT
1/8"	Low	SILT & CLAY
1/16"	Medium	CLAY & SILT
1/32"	High	Silty CLAY
1/64"	Very High	CLAY

Wetted sample is rolled in hands to smallest possible diameter before breaking.

ORGANIC SILT: Typically gray to dark gray, often has strong H₂S odor. May contain shells or shell fragments. Light weight.

Fibrous PEAT: Light weight, spongy, mostly visible organic matter, water squeezed readily from sample. Typically near top of layer.

Fine grained PEAT: Light weight, spongy, little visible organic matter, water squeezed from sample. Typically below fibrous peat.

DEBRIS: Detailed contents described in parentheses (wood, glass, ash, crushed brick, metal, etc.)

BEDROCK: Underlying rock beneath loose soil, can be weathered (easily crushed) or competent (difficult to crush).

ADDITIONAL CONSTITUENTS

TERM	% OF TOTAL
and	35-50%
some	20-35%
little	10-20%
trace	1-10%

COMMON TERMS

Glacial till: Very dense/hard, heterogeneous mixture of sand, silt, clay, sub-angular gravel. Deposited at base of glaciers, which covered all of New England.
Varved clay: Fine-grained, post-glacial lake sediments characterized by alternating layers (or varves) of silt, sand and clay.
Fill: Material used to raise ground, can be engineered or non-engineered.

COMMON FIELD MEASUREMENTS

Torvane: Undrained shear strength is estimated using an E285 Pocket Torvane (TV). Values in tons/ft².

Penetrometer: Unconfined compressive strength is estimated using a Pocket Penetrometer (PP). Values in tons/ft².

RQD: Rock Quality Designation is determined by measuring total length of pieces of core 4" or greater and dividing by the total length of the run, expressed as %. 100-90% excellent; 90-75% good; 75-50% fair; 50-25% poor; 25-0% very poor.

PID: Soil screened for volatile organic compounds (VOCs) using a photoionization detector (PID) referenced to benzene in air. Readings in parts per million by volume.

LOG OF BORING WB-1

PROJECT	White Brook Culvert			CONTRACTOR	Seaboard Environmental Drilling			
JOB NUMBER	2393-08-01	FINAL DEPTH (ft)	27.0	DRILLING EQUIPMENT	B-53 Truck Mounted Rig			
LOCATION	Agawam, MA	SURFACE ELEV (ft)	131.0	FOREMAN	Dale	CASING		
START DATE	11/12/2020	DISTURBED SAMPLES	6	HELPER	Mike	CASE DIAMETER	N/A	
FINISH DATE	11/12/2020	UNDISTURBED SAMPLES	0	BIT TYPE	Hollow Stem Auger		HAMMER WGT	N/A
ENGINEER/SCIENTIST	Shannon Raymond		WATER LEVEL	ROD TYPE	A (1 5/8" O.D.)		HAMMER DROP	N/A
BORING LOCATION	Northeast of existing culvert	FIRST (ft)	15.0	SAMPLER	2" O.D. Split Spoon		ROCK CORING INFORMATION	
		LAST (ft)	--	HAMMER TYPE	Automatic		TYPE	N/A
		TIME (hr)	--	HAMMER WGT/DROP	140 lb / 30"		SIZE	N/A

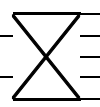
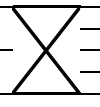
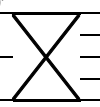
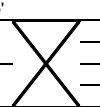
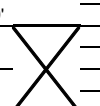
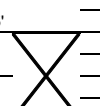
DEPTH (ft)/ SAMPLES	SAMPLES				SAMPLE DESCRIPTION (MODIFIED BURMISTER)	PROFILE		REMARKS/ WELL CONSTRUCTION	
	PENETR. RESIST. (bl / 6 in)	REC. (in)	TYPE/ NO.	FIELD TEST DATA		DEPTH (ft)	ELEV.		
	9/13/10/7	14/24	S-1 (0.75'-2.75')	--	9" of Asphalt Top 6" : Medium dense, red-brown, fine to medium SAND, some coarse sand, little gravel, trace silt, dry (SAND AND GRAVEL BASE) Bottom 8" : Medium dense, red-brown, fine to medium SAND, little coarse sand, trace (+) silt, trace debris (asphalt), dry (GRANULAR FILL)	ASPHALT GRANULAR BASE GRANULAR FILL/ REWORKED SITE SOILS			
	2/3/2/2	13/24	S-2 (5'-7')	--	Top 7" : Loose, brown, fine to medium SAND, little coarse sand, trace (+) silt, dry Bottom 6" : Loose, brown, fine SAND, little silt, little medium sand, trace debris (asphalt) damp				
	4/4/5/10	12/24	S-3 (10'-12')	--	Top 8" : Loose, brown, fine SAND, some to little silt, trace medium sand, damp Bottom 4" : Loose, light brown, fine to medium SAND, trace silt, trace gravel, damp				
	1/1/2/1	15/24	S-4 (15'-17')	--	Soft, grey-brown, varved SILT and CLAY, little fine sand, wet			15.0	116.0
	1/1/2/3	20/24	S-5 (20'-22')	--	Soft, grey, varved SILT and CLAY, little fine sand, wet				
	2/2/2/2	24/24	S-6 (25'-27')	--	Soft, grey, varved SILT and CLAY, little fine sand, wet				
End of exploration at 27'								27.0	104.0

Remarks: 1. Auger easily advanced beginning at 17 feet below ground surface.	PROJECT NO. 2393-08-01
	LOG OF BORING WB-1

LOG OF BORING WB-2

PROJECT	White Brook Culvert			CONTRACTOR	Seaboard Environmental Drilling		
JOB NUMBER	2393-08-01	FINAL DEPTH (ft)	27.0	DRILLING EQUIPMENT	B-53 Truck Mounted Rig		
LOCATION	Agawam, MA	SURFACE ELEV (ft)	129.0	FOREMAN	Dale	CASING	
START DATE	11/12/2020	DISTURBED SAMPLES	6	HELPER	Mike	CASE DIAMETER	N/A
FINISH DATE	11/12/2020	UNDISTURBED SAMPLES	0	BIT TYPE	Hollow Stem Auger	HAMMER WGT	N/A
ENGINEER/SCIENTIST	Shannon Raymond		WATER LEVEL	ROD TYPE	A (1 5/8" O.D.)	HAMMER DROP	N/A
BORING LOCATION	Southeast of existing culvert	FIRST (ft)	10.0	SAMPLER	2" O.D. Split Spoon	ROCK CORING INFORMATION	
		LAST (ft)	--	HAMMER TYPE	Automatic	TYPE	N/A
		TIME (hr)	--	HAMMER WGT/DROP	140 lb / 30"	SIZE	N/A

DEPTH (ft)/ SAMPLES	SAMPLES				SAMPLE DESCRIPTION (MODIFIED BURMISTER)	PROFILE		REMARKS/ WELL CONSTRUCTION
	PENETR. RESIST. (bl / 6 in)	REC. (in)	TYPE/ NO.	FIELD TEST DATA		DEPTH (ft)	ELEV.	
0-5'	3/8/7/7	13/24	S-1 (0'-2')	--	Top 3" : Medium dense, dark brown, fine to medium SAND, trace (+) silt, trace organics (roots), damp (TOPSOIL) Bottom 10" : Medium dense, brown to red-brown, medium to coarse SAND, some fine sand little to trace silt, trace gravel, trace debris (asphalt, brick), damp (GRANULAR FILL)	TOPSOIL		1.
						GRANULAR FILL/ REWORKED SITE SOILS		
5-10'	2/1/1/1	15/24	S-2 (5'-7')	--	Loose, brown to light brown, fine to medium SAND, little to trace silt, trace fine gravel, trace (-) organics (roots), damp			1.
10-15'	3/3/3/3	17/24	S-3 (10'-12')	--	Top 9" : Loose, grey-brown, medium to coarse SAND, some fine sand, little silt, wet Middle 5" : Loose, grey, fine SAND and SILT, wet Bottom 3" : Soft, grey, varved SILT and CLAY (1/16" seams of silt, 1/16" seams of clay)	119.0 118.0	SILT AND CLAY	
15-20'	2/2/2/2	18/24	S-4 (15'-17')	--	Soft, grey, varved SILT and CLAY, trace fine sand, wet			
20-25'	2/1/1/2	20/24	S-5 (20'-22')	--	Soft, grey, varved SILT and CLAY, trace fine sand, wet			
25-27'	2/2/2/2	24/24	S-6 (25'-27')	--	Soft, grey, varved SILT and CLAY, trace fine sand, wet			
End of exploration at 27'						27.0	102.0	

Remarks: 1. Auger grinding at 2 and 4 feet below ground surface, suspected gravel.	PROJECT NO. 2393-08-01
	LOG OF BORING WB-2



APPENDIX C – RECENT (2022) BORING LOGS BY GZA

BORING LOG GUIDE

BORING LOG LEGEND

GS Elev. = Ground Surface Elevation
 NAVD = North American Vertical Datum
 NR = No Recovery
 S.S. = Split Spoon

Stab. = Stabilization Time for groundwater reading
 WOH = Weight of Hammer
 WOR = Weight of Rods

SOIL DESCRIPTIONS

Soil samples are described on the exploration logs by the "Modified Burmister Soil Identification System". The following provides a brief description of the Modified Burmister System.

- Major and minor components of the soil matrix are identified as gravel, sand or fines. The relative amounts of these constituents are proportioned as:

Component	Proportional Term	Percent by Weight of Total
Major		Greater than percentage of other components
Minor	And	35-50
	Some	20-35
	Little	10-20
	Trace	1-10

- The nature of "fines" is defined by using the following guidelines:

Degree of Plasticity	Identity	Plasticity Index
Non-plastic	SILT	0
Slight	Clayey SILT	1-5
Low	SILT & CLAY	5-10
Medium	CLAY & SILT	10-20
High	Silty CLAY	20-40
Very High	CLAY	40 and Greater

- For boring logs, relative density or consistency is identified based on standard penetration resistance, using the following table.

Non-Plastic Soils		Plastic Soils	
Blows/ft "N"	Relative Density	Blows/ft "N"	Consistency
0-4	Very Loose	<2	Very Soft
4-10	Loose	2-4	Soft
10-30	Medium Dense	4-8	Medium Stiff
30-50	Dense	8-15	Stiff
>50	Very Dense	15-30	Very Stiff
		>30	Hard

BEDROCK DESCRIPTIONS

Rock samples described on the exploration logs are generally based on the International Society of Rock Mechanics (ISRM) System, as generally described on the following page. Each rock sample was generally described using the following guideline, in the order presented:

- Field hardness: very hard, hard, moderately hard, medium, soft, very soft
- Weathering: fresh, very slight, slight, moderate, moderately severe, severe, very severe, complete
- Rock continuity (fracturing): extremely, moderately, slightly, sound
- Texture: amorphous, fine, medium, coarse, very coarse
- Color
- Rock type
- Fractures, Bedding, and Foliation, Spacing and Attitude
- Rock Quality Designation (RQD)

TEST BORING LOG



GZA
GeoEnvironmental, Inc.
Engineers and Scientists

Woodard & Curran
Proposed Culvert Replacement
North Street Culvert
Agawam, Massachusetts

BORING NO.: BB-01
SHEET: 1 of 2
PROJECT NO: 01.0177018.00
REVIEWED BY: MJO/MAR

Drilling Co.: Seaboard Drilling Foreman: Dale Griffen Logged By: Matthew Brady	Type of Rig: Truck Rig Model: Mobile B-53 Drilling Method: Drive & Wash	Boring Location: See Plan Ground Surface Elev. (ft.): 136.5 Final Boring Depth (ft.): 52.5 Date Start - Finish: 12/30/2022 - 12/30/2022	H. Datum: NAD83 V. Datum: NAVD88																				
Auger/Casing Type: HW I.D./O.D.(in): 4/4.5 Hammer Weight (lb.): 300 Hammer Fall (in.): 24 Other: Safety Hammer	Sampler Type: Split Spoon I.D./O.D. (in.): 1-3/8/2 Sampler Hmr Wt (lb): 140 Sampler Hmr Fall (in): 30 Other: Auto Hammer	Groundwater Depth (ft.)																					
		<table border="1" style="width: 100%; border-collapse: collapse;"> <thead> <tr> <th>Date</th> <th>Time</th> <th>Water Depth</th> <th>Casing</th> <th>Stab. Time</th> </tr> </thead> <tbody> <tr> <td colspan="5" style="text-align: center;">No stabilized readings obtained</td> </tr> <tr> <td> </td> <td> </td> <td> </td> <td> </td> <td> </td> </tr> <tr> <td> </td> <td> </td> <td> </td> <td> </td> <td> </td> </tr> </tbody> </table>	Date	Time	Water Depth	Casing	Stab. Time	No stabilized readings obtained															
Date	Time	Water Depth	Casing	Stab. Time																			
No stabilized readings obtained																							

Depth (ft)	Casing Blows/Core Rate	Sample					SPT Value	Sample Description and Identification (Modified Burmister Procedure)	Remark	Field Test Data	Depth (ft.)	Stratum Description	Elev. (ft.)
		No.	Depth (ft.)	Pen. (in)	Rec. (in)	Blows (per 6 in.)							
5		S-1	0-2	24	4	3 4 5 4	9	S-1: Loose, brown, fine to coarse SAND, little Silt, little Gravel.	1 2				
		S-2	2-4	24	5	3 2 2 3	4	S-2: Medium stiff, gray/brown Clayey SILT, little fine Sand, trace Organics.					
		S-3	4-6	24	10	3 3 3 3	6	S-3: Medium stiff, gray, SILT & CLAY, trace (+) fine Sand.					
		S-4	6-8	24	7	4 3 3 4	6	S-4: Medium stiff, dark gray, SILT & CLAY, trace (-) fine Sand.					
		S-5	8-10	24	15	3 3 3 3	6	S-5: Medium stiff, gray, CLAY & SILT, trace fine Sand.			FILL		
10		S-6	10-12	24	12	4 4 4 4	8	S-6: Stiff, gray/brown/red, SILT & CLAY, trace (-) fine Sand.					
		S-7	13-15	24	14	2 3 3 4	6	S-7: Medium stiff, gray, SILT & CLAY, trace (-) fine Sand.					
15											16.5'	120.0'	
		S-8	18-20	24	17	2 2 2 2	4	S-8 (Top 6"): Gray and brown, SILT & CLAY, trace (+) fine Sand. S-8 (Bottom 11"): Gray, SILT & CLAY, trace (-) fine Sand.	3 4				
20													
		S-9	23-25	24	24	2 3 2 2	5	S-9: Medium stiff, gray with red, SILT & CLAY. (varved deposit)			VARVED SILT & CLAY		
25													
		S-10	28-30	24	22	1 1 1 1	2	S-10 (Top 14"): Soft, gray with red, SILT & CLAY. (varved deposit)					
30													

REMARKS

- Ground surface elevation estimated from the topography shown on preliminary design plan NO. C-100 entitled "Existing Conditions Plan" prepared by Woodard & Curran and dated October 2022.
- Advanced borehole using cased drive and wash techniques from 0 to 18 feet below existing ground surface (bgs).
- Advanced borehole using open hole drilling techniques below 18 feet bgs.
- In samples S-8 through the top portion of S-12 Silt & Clay were observed in alternating sub-layers (varves).

See Log Key for explanation of sample description and identification procedures. Stratification lines represent approximate boundaries between soil and bedrock types. Actual transitions may be gradual. Water level readings have been made at the times and under the conditions stated. Fluctuations of groundwater may occur due to other factors than those present at the times the measurements were made.

Boring No.:
BB-01

177018.00 NORTH STREET CULVERT-AGAWAM, MA.GPJ-STRATUM ONLY NORWOOD: 5/19/2023

TEST BORING LOG



GZA
GeoEnvironmental, Inc.
Engineers and Scientists

Woodard & Curran
Proposed Culvert Replacement
North Street Culvert
Agawam, Massachusetts

BORING NO.: BB-01
SHEET: 2 of 2
PROJECT NO: 01.0177018.00
REVIEWED BY: MJO/MAR

Depth (ft)	Casing Blows/ Core Rate	Sample						SPT Value	Sample Description and Identification (Modified Burmister Procedure)	Remark	Field Test Data	Depth (ft.)	Stratum Description	Elev. (ft.)
		No.	Depth (ft.)	Pen. (in)	Rec. (in)	Blows (per 6 in.)								
35		S-11	33-35	24	24	2 3 4 5	7	S-10 (Bottom 8"): Red/gray, Silty CLAY. (varved deposit)						
		S-12	35-37	24	14	5 5 5 5	10	S-11: Medium stiff, gray/red, Silty CLAY, trace(-) fine Sand. S-12 (Top 7"): Gray/red, Silty CLAY, trace(-) fine Sand. S-12 (Bottom 7"): Gray/red/brown, Silty CLAY, some fine to coarse Sand, little Gravel.			35.6'		100.9'	
40		S-13	40-42	24	14	8 9 12 12	21	S-13: Very Stiff, red/brown Silty CLAY, some fine to coarse Sand, some Gravel.						
		C-1	42.5-47.5	60	58			C-1: Hard, fresh to slightly weathered, amorphous to fine-grained, brown/red SILTSTONE, with very thin subhorizontal bedding and moderately close to very close subhorizontal to moderately dipping joints/fractures. RQD=75%	5		42.5'		94.0'	
45	7:08													
	6:27													
50	6:46													
	5:57	C-2	47.5-52.5	60	55			C-2: Hard, fresh to slightly weathered, amorphous to fine-grained, brown/red SILTSTONE, with very thin subhorizontal bedding and close to very close subhorizontal to moderately dipping joints/fractures. RQD=67%						
	4:48													
	3:50													
	3:10													
	3:53													
	3:29													
	2:43													
								Bottom of boring at 52.5 feet.	6			52.5'	84.0'	

REMARKS
 5. Driller noted greatly increased resistance roller biting at 42.5 feet bgs and indicated the presence of bedrock. Bedrock was then cored starting at 42.5 feet bgs.
 6. Upon completion, borehole backfilled with drill cuttings to ground surface.

See Log Key for explanation of sample description and identification procedures. Stratification lines represent approximate boundaries between soil and bedrock types. Actual transitions may be gradual. Water level readings have been made at the times and under the conditions stated. Fluctuations of groundwater may occur due to other factors than those present at the times the measurements were made.

Boring No.:
BB-01

177018.00 NORTH STREET CULVERT-AGAWAM, MA.GPJ; STRATUM ONLY NORWOOD; 5/19/2023

TEST BORING LOG



GZA
GeoEnvironmental, Inc.
Engineers and Scientists

Woodard & Curran
Proposed Culvert Replacement
North Street Culvert
Agawam, Massachusetts

BORING NO.: BB-02
SHEET: 1 of 2
PROJECT NO: 01.0177018.00
REVIEWED BY: MJO/MAR

Drilling Co.: Seaboard Drilling	Type of Rig: Truck	Boring Location: See Plan	H. Datum: NAD83
Foreman: Dale Griffen	Rig Model: Mobile B-53	Ground Surface Elev. (ft.): 135	V. Datum: NAVD88
Logged By: Matthew Brady	Drilling Method: Drive & Wash	Final Boring Depth (ft.): 56.8	
		Date Start - Finish: 12/28/2022 - 12/28/2022	

Auger/Casing Type: HW	Sampler Type: Split Spoon	Groundwater Depth (ft.)			
I.D./O.D.(in): 4/4.5	I.D./O.D. (in.): 1-3/8/2	Date	Time	Water Depth	Casing
Hammer Weight (lb.): 300	Sampler Hmr Wt (lb): 140	No stabilized readings obtained			
Hammer Fall (in.): 24	Sampler Hmr Fall (in): 30				
Other: Safety Hammer	Other: Auto Hammer				

Depth (ft)	Casing Blows/ Core Rate	Sample No.	Sample				SPT Value	Sample Description and Identification (Modified Burmister Procedure)	Remark	Field Test Data	Stratum Description	Elev. (ft.)
			Depth (ft.)	Pen. (in)	Rec. (in)	Blows (per 6 in.)						
5		S-1	0.5-2.5	24	10	25 18 17 16	35	0-6": ASPHALT. S-1: Tan, fine to coarse SAND, little Gravel, trace Silt.	1 2 3		ASPHALT	134.5'
15		S-2	13-15	24	0	9 4 2 3	6	S-2: No recovery.	4 5		FILL	
20		S-3	18-20	24	5	3 1 2 1	3	S-3: Soft, gray, SILT & CLAY, little fine Sand, little(-) Wood fibers.	6			
25		S-4	23-25	24	0	0 1 2 1	3	S-4: No recovery.				
30		S-5	28-30	24	24	0 1 1 2	2	S-5: Very soft, gray, CLAY & SILT, trace (-) fine Sand.				

REMARKS

- Ground surface elevation estimated from the topography shown on preliminary design plan NO. C-100 entitled "Existing Conditions Plan" prepared by Woodard & Curran and dated October 2022.
- Augered through the pavement then obtained sample S-1.
- Advanced borehole using cased drive and wash techniques from 0.5 to 18 feet below existing ground surface (bgs). Driller noted the presence of wood in the wash water.
- Stratum change at 15 feet bgs estimated based on the depth to the existing culvert and nearby previous boring WB-1 by others.
- In samples S-3 and S-5 through S-9 Silt & Clay were observed in alternating sub-layers (varves).
- Advanced borehole using open hole drilling techniques below 18 feet bgs. Drill cuttings and occasional low sample recoveries appeared to be due to pushing a piece of wood from the fill stratum.

See Log Key for explanation of sample description and identification procedures. Stratification lines represent approximate boundaries between soil and bedrock types. Actual transitions may be gradual. Water level readings have been made at the times and under the conditions stated. Fluctuations of groundwater may occur due to other factors than those present at the times the measurements were made.

Boring No.:
BB-02

177018.00 NORTH STREET CULVERT-AGAWAM, MA.GPJ-STRATUM ONLY NORWOOD: 5/19/2023

TEST BORING LOG



GZA
GeoEnvironmental, Inc.
Engineers and Scientists

Woodard & Curran
Proposed Culvert Replacement
North Street Culvert
Agawam, Massachusetts

BORING NO.: BB-02
SHEET: 2 of 2
PROJECT NO: 01.0177018.00
REVIEWED BY: MJO/MAR

Depth (ft)	Casing Blows/ Core Rate	Sample						SPT Value	Sample Description and Identification (Modified Burmister Procedure)	Remark	Field Test Data	Depth (ft.)	Stratum Description	Elev. (ft.)
		No.	Depth (ft.)	Pen. (in)	Rec. (in)	Blows (per 6 in.)								
35		S-6	33-35	24	0	3 3 4 3	7	S-6: No recovery.						
40		S-7	38-40	24	22	1 3 5 3	8	S-7: Stiff, gray, Silty CLAY, trace (-) fine Sand.				VARVED SILT AND CLAY		
45		S-8	43-45	24	17	3 2 3 2	5	S-8 (Top 12"): Gray, Silty CLAY, trace (-) fine Sand. S-8 (Bottom 5"): Brown, SILT and CLAY, trace (-) fine Sand.						
50		S-9	48-50	24	22	3 1 2 11	3	S-9: Soft, brown, Clayey SILT, some fine to coarse Sand, little Gravel.				49.5'	85.5'	
55		S-10	53-53.8	24	2	9 50/3"	R	S-10: Brown, Clayey SILT and fine to coarse SAND, some Gravel.	7 8			53.8'	81.2'	
								Bottom of boring at 56.8 feet.	9			56.8'	78.2'	
60														
65														

REMARKS

7. Driller indicated top of bedrock at approximately 53.8 feet bgs. Roller bitted from approximately 53.8 to 56.8 feet bgs using approximately 450 psi downpressure over approximately 80 minutes. Drill cuttings appeared to consist of 1/8-inch pieces of red siltstone.
8. Driller indicated there was a 3 inch fracture in the rock and was losing water.
9. Upon completion, borehole backfilled with drill cuttings and patched the surface with concrete.

See Log Key for explanation of sample description and identification procedures. Stratification lines represent approximate boundaries between soil and bedrock types. Actual transitions may be gradual. Water level readings have been made at the times and under the conditions stated. Fluctuations of groundwater may occur due to other factors than those present at the times the measurements were made.

Boring No.:
BB-02

177018.00 NORTH STREET CULVERT-AGAWAM, MA.GPJ; STRATUM ONLY NORWOOD; 5/19/2023

TEST BORING LOG



GZA
GeoEnvironmental, Inc.
Engineers and Scientists

Woodard & Curran
 Proposed Culvert Replacement
 North Street Culvert
 Agawam, Massachusetts

BORING NO.: BB-03
SHEET: 1 of 2
PROJECT NO: 01.0177018.00
REVIEWED BY: MJO/MAR

Drilling Co.: Seaboard Drilling	Type of Rig: Truck	Boring Location: See Plan	H. Datum: NAD83
Foreman: Dale Griffen	Rig Model: Mobile B-53	Ground Surface Elev. (ft.): 132.5	V. Datum: NAVD88
Logged By: Matthew Brady	Drilling Method: Drive & Wash	Final Boring Depth (ft.): 66.5	
		Date Start - Finish: 12/29/2022 - 12/29/2022	

Auger/Casing Type: HW	Sampler Type: Split Spoon	Groundwater Depth (ft.)		
I.D./O.D.(in): 4/4.5	I.D./O.D. (in.): 1-3/8/2	Date	Time	Water Depth
Hammer Weight (lb.): 300	Sampler Hmr Wt (lb): 140	No stabilized readings obtained		
Hammer Fall (in.): 24	Sampler Hmr Fall (in): 30			
Other: Safety Hammer	Other: Auto Hammer			

Depth (ft)	Casing Blows/ Core Rate	Sample No.	Sample			Blows (per 6 in.)	SPT Value	Sample Description and Identification (Modified Burmister Procedure)	Remark	Field Test Data	Depth (ft.)	Stratum Description	Elev. (ft.)
			Depth (ft.)	Pen. (in)	Rec. (in)								
5		S-1	0-2	24	14	27 30	54	S-1: Very dense, brown/red/tan/white, GRAVEL and fine to coarse SAND, little Silt.	1				
						24 22							
15		S-2	13-15	24	7	9 8	16	S-2: Very stiff, gray, SILT and CLAY, little fine to coarse Sand, trace (-) Gravel.	5				
						8 6							
25		S-3	23-25	24	24	1 1	2	S-3: Soft, gray, CLAY and SILT, trace (-) fine Sand.					
						1 1							

REMARKS

- Ground surface elevation estimated from the topography shown on preliminary design plan NO. C-100 entitled "Existing Conditions Plan" prepared by Woodard & Curran and dated October 2022.
- Advanced borehole from 0 to 13 feet below existing ground surface (bgs) using cased drive and wash techniques.
- Stratum change estimated at 11.5 feet bgs based on nearby previous boring WB-2 by others.
- In samples S-2 through S-6 Silt & Clay were observed in alternating sub-layers (varves).
- Advanced borehole below 13 feet bgs using open hole drilling techniques.

See Log Key for explanation of sample description and identification procedures. Stratification lines represent approximate boundaries between soil and bedrock types. Actual transitions may be gradual. Water level readings have been made at the times and under the conditions stated. Fluctuations of groundwater may occur due to other factors than those present at the times the measurements were made.

Boring No.:
BB-03

177018.00 NORTH STREET CULVERT-AGAWAM, MA.GPJ-STRATUM ONLY NORWOOD: 5/19/2023

TEST BORING LOG



GZA
GeoEnvironmental, Inc.
Engineers and Scientists

Woodard & Curran
Proposed Culvert Replacement
North Street Culvert
Agawam, Massachusetts

BORING NO.: BB-03
SHEET: 2 of 2
PROJECT NO: 01.0177018.00
REVIEWED BY: MJO/MAR

Depth (ft)	Casing Blows/ Core Rate	Sample						Sample Description and Identification (Modified Burmister Procedure)	Remark	Field Test Data	Depth (ft.)	Stratum Description	Elev. (ft.)
		No.	Depth (ft.)	Pen. (in)	Rec. (in)	Blows (per 6 in.)	SPT Value						
35		S-4	33-35	24	24	1 1 1 1	2	S-4: Soft, gray and little red, Silty CLAY, trace (-) fine Sand.					
45		S-5	43-45	24	24	2 4 1 2	5	S-5: Medium stiff, gray/reddish, Silty CLAY.				VARVED SILT & CLAY	
55		S-6	53-55	24	24	2 3 10 9	13	S-6 (Top 19"): Stiff, gray/reddish, Silty CLAY. S-6 (Bottom 5"): Brown/red, Clayey SILT and fine to coarse SAND, little Gravel.			54.5'	78.0'	
60												GLACIAL TILL	
65									6			62.5'	70.0'
									7				BEDROCK
												66.5'	66.0'

REMARKS

6. Drill noted bedrock at 62.5 feet bgs. Roller bitted with a 4-inch roller bit from 62.5 to 66.5 feet bgs under 300 psi downpressure in approximately 45 minutes. The drill cuttings appeared to consist of 1/16- to 1/4-inch reddish siltstone.
7. Upon completion, borehole backfilled with drill cuttings.

Bottom of boring at 66.5 feet.

177018.00 NORTH STREET CULVERT-AGAWAM, MA.GPJ; STRATUM ONLY NORWOOD; 5/19/2023

See Log Key for explanation of sample description and identification procedures. Stratification lines represent approximate boundaries between soil and bedrock types. Actual transitions may be gradual. Water level readings have been made at the times and under the conditions stated. Fluctuations of groundwater may occur due to other factors than those present at the times the measurements were made.

Boring No.:
BB-03



APPENDIX D – 2022 ROCK CORE PHOTOGRAPHS

Boring No.	Core Run	Core Depths (ft)		Core Recovery		Rock Quality Designation (RQD, %)
		Top	Bottom	Rec. (in)	%	
BB-01	C-1	42.5	47.5	58	97	75
BB-01	C-2	47.5	52.5	55	92	67
-	-	-	-	-	-	-
-	-	-	-	-	-	-



Dry Condition



Wet Condition



North Street over White Brook, Agawam, MA
Culvert Replacement

Rock Core Photographs

Boring
BB-01



APPENDIX E – PREVIOUS (2020) GEOTECHNICAL LABORATORY TEST RESULTS BY OTHERS

Particle Size Distribution Report

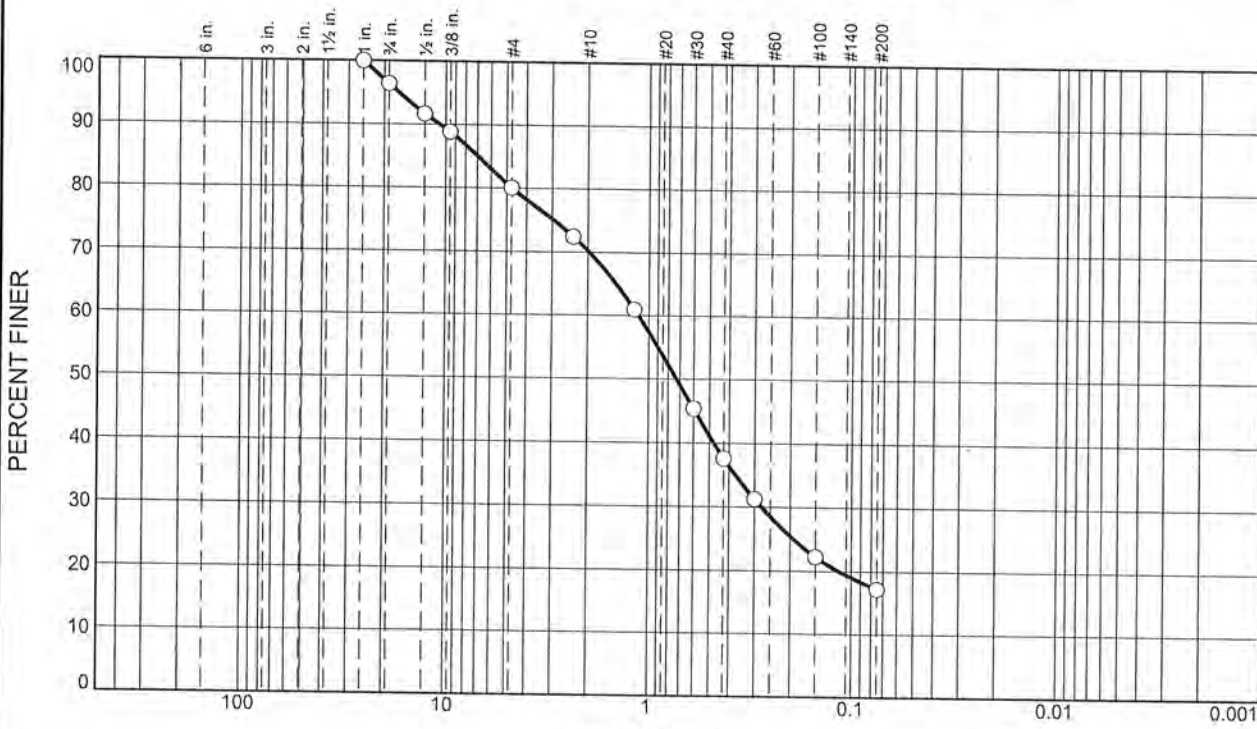

% +3"	% Gravel		% Sand			% Fines	
	Coarse	Fine	Coarse	Medium	Fine	Silt	Clay
0.0	3.6	16.3	9.9	32.6	20.4	17.2	

Test Results (ASTM C 136 & ASTM C 117)			
Opening Size	Percent Finer	Spec.* (Percent)	Pass? (X=Fail)
1	100.0		
3/4	96.4		
1/2	91.7		
3/8	88.8		
#4	80.1		
#8	72.5		
#16	61.0		
#30	45.3		
#40	37.6		
#50	31.3		
#100	22.2		
#200	17.2		

* (no specification provided)

Material Description

WB-1 1'-5'

Atterberg Limits (ASTM D 4318)

PL= LL= PI=

Classification

USCS (D 2487)= AASHTO (M 145)=

Coefficients

D₉₀= 10.7093 D₈₅= 6.9724 D₆₀= 1.1265
D₅₀= 0.7291 D₃₀= 0.2768 D₁₅=
D₁₀= C_u= C_c=

Remarks

This sample delivered to lab by client. This sample was washed

Date Received: 11/12/2020 Date Tested: 11/13/2020

Tested By: _____

Checked By: John McGreevy

Title: Dir. of Testing Services

Sample Number: 2521 Depth: 1'-5' Date Sampled: 11/12/2020

Particle Size Distribution Report

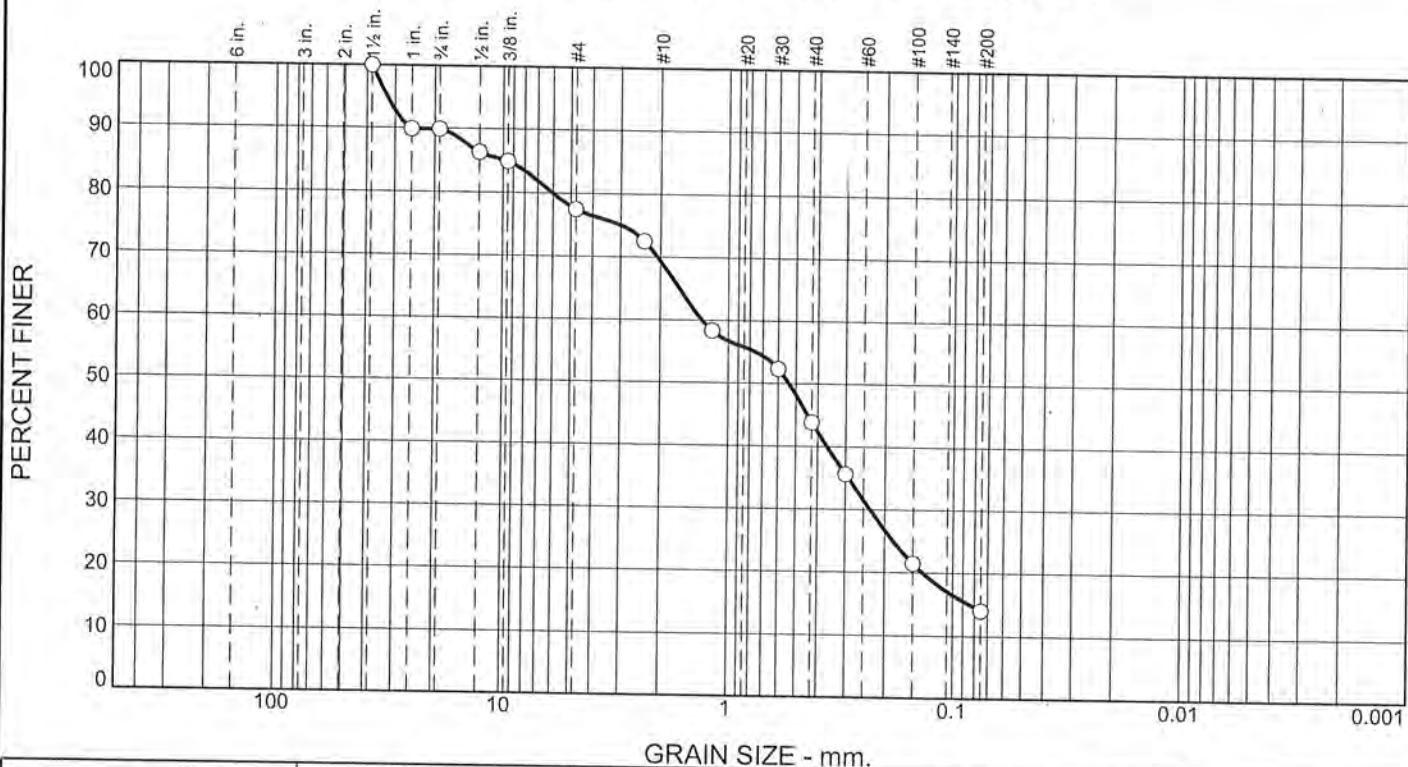

% +3"	% Gravel		% Sand			% Fines	
	Coarse	Fine	Coarse	Medium	Fine	Silt	Clay
0.0	10.2	12.3	8.1	25.6	29.8	14.0	

Test Results (ASTM C 136 & ASTM C 117)			
Opening Size	Percent Finer	Spec.* (Percent)	Pass? (X=Fail)
1.5	100.0		
1	89.8		
3/4	89.8		
1/2	86.3		
3/8	84.9		
#4	77.5		
#8	72.5		
#16	58.3		
#30	52.3		
#40	43.8		
#50	35.6		
#100	21.5		
#200	14.0		

* (no specification provided)

Material Description

WB-2 1'-5'

Atterberg Limits (ASTM D 4318)

PL= LL= PI=

Classification

USCS (D 2487)= AASHTO (M 145)=

Coefficients

D₉₀= 25.9024 D₈₅= 9.7390 D₆₀= 1.3084
 D₅₀= 0.5381 D₃₀= 0.2331 D₁₅= 0.0842
 D₁₀= C_u= C_c=

Remarks

This sample delivered to lab by client. This sample was washed

Date Received: 11/12/2020 **Date Tested:** 11/13/2020
Tested By: _____
Checked By: John McGreevy
Title: Dir. of Testing Services

Sample Number: 2522 **Depth:** 1'-5' **Date Sampled:** 11/12/2020

ALLIED TESTING LABORATORIES, INC. Springfield, Massachusetts	Client: O'Reilly Talbot & Okun Associates Project: Agawam White Brook Culvert Project No: OTO #2393-08-01
Figure	



APPENDIX F – RECENT (2022) GEOTECHNICAL LABORATORY TEST RESULTS



195 Frances Avenue
 Cranston RI, 02910
 Phone: (401)-467-6454
 Fax: (401)-467-2398
thielsch.com
Let's Build a Solid Foundation

Client Information:
 GZA GeoEnvironmental
 Norwood, MA 02062
 PM: Michael Ostrowski
 Assigned By: Michael Ostrowski
 Collected By: Matt Brady

Project Information:
North Street over White Brook Culvert
Agawam, MA
 Project Number: 01.0177018.00
 Summary Page: 1 of 1
 Report Date: 01.16.23

LABORATORY TESTING DATA SHEET, Report No.: 7423-A-119

Boring No.	Sample No.	Depth (ft)	Laboratory No.	Identification Tests								Proctor / CBR / Permeability Tests							Laboratory Log and Soil Description		
				As Rcvd Moisture Content %	LL %	PL %	Gravel %	Sand %	Fines %	Org. %	pH	Dry unit wt. (pcf)	Test Moisture Content %	γ_d MAX (pcf) / W_{opt} (%)	γ_d MAX (pcf) / W_{opt} (%) (Corr.)	Target Test Setup as % of Proctor	CBR @ 0.1"	CBR @ 0.2"		Permeability cm/sec	
				D2216	D4318		D6913			D2974	D4792			D1557							
BB-02	S-1	0.5-2.5	23-S-091				14.9	73.9	11.2											Brown f-c SAND, little fine Gravel, little Silt	
BB-03	S-2	13-15	23-S-092				8.8	9.8	81.4											Gray CLAY & SILT, trace f-c Sand, trace fine Gravel	

Date Received: 01.10.23

Reviewed By: 

Date Reviewed: 01.16.23

This report only relates to items inspect and/or tested. No warranty, expressed or implied, is made.
 This report shall not be reproduced, except in full, without prior written approval from the Agency, as defined in ASTM E329.

These results are for the exclusive use of the client for whom they were obtained. They apply only to the samples tested and are not indicative of apparently identical samples.

Particle Size Distribution Report

ASTM D6913



% +3"	% Gravel		% Sand			% Fines	
	Coarse	Fine	Coarse	Medium	Fine	Silt	Clay
0.0	0.0	14.9	9.0	34.2	30.7	11.2	

Sieve Size or Diam. (mm.)	Finer (%)	Spec.* (%)	Out of Spec. (%)	Pct. of Fines
3/4"	100.0			
1/2"	97.0			
3/8"	93.8			
#4	85.1			
#10	76.1			
#20	60.0			
#40	41.9			
#60	28.8			
#100	19.0			
#200	11.2			

Material Description
Brown f-c SAND, little fine Gravel, little Silt

PL= NP Atterberg Limits LL= NV PI= NP

Coefficients

D₉₀= 7.0416 D₈₅= 4.7060 D₆₀= 0.8517
D₅₀= 0.5750 D₃₀= 0.2635 D₁₅= 0.1088
D₁₀= C_u= C_c=

USCS= SP-SM Classification AASHTO= A-1-b

Test Remarks

* (no specification provided)

Source of Sample: Boring Depth: 0.5-2.5'
Sample Number: BB-02 / S-1

Sample Date: 01.16.23

Thielsch Engineering Inc. Cranston, RI	Client: GZA GeoEnvironmental
	Project: North Street over White Brook Culvert Agawam, MA
Project No: 01.0177018.00	Figure 23-S-091

Tested By: RB / AV

Checked By:

These results are for the exclusive use of the client for whom they were obtained. They apply only to the samples tested and are not indicative of apparently identical samples.

Particle Size Distribution Report

ASTM D6913

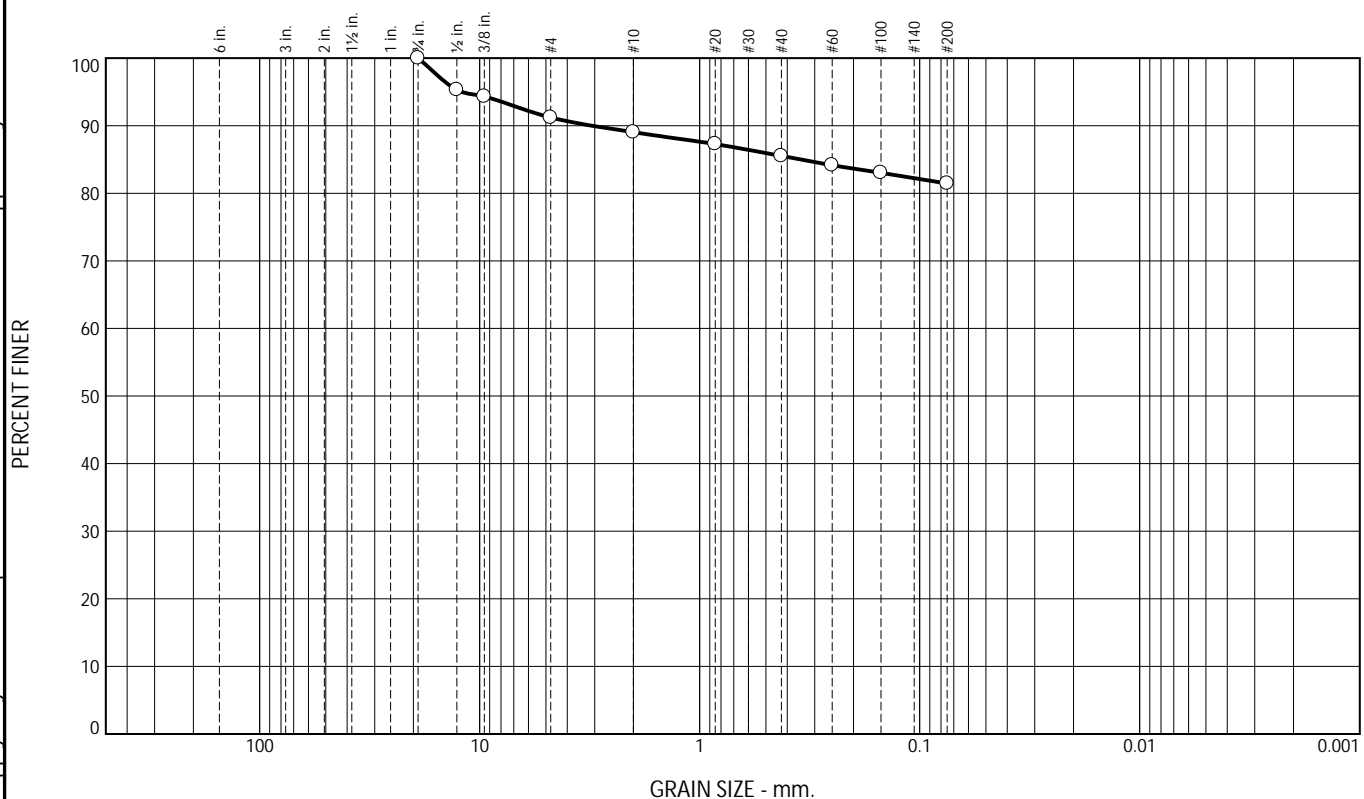

% +3"	% Gravel		% Sand			% Fines	
	Coarse	Fine	Coarse	Medium	Fine	Silt	Clay
0.0	0.0	8.8	2.2	3.5	4.1	81.4	

Test Results (ASTM D6913)				
Sieve Size or Diam. (mm.)	Finer (%)	Spec. * (%)	Out of Spec. (%)	Pct. of Fines
3/4"	100.0			
1/2"	95.3			
3/8"	94.3			
#4	91.2			
#10	89.0			
#20	87.3			
#40	85.5			
#60	84.2			
#100	83.0			
#200	81.4			

Material Description

Gray CLAY & SILT, trace f-c Sand, trace fine Gravel

PL=	<u>Atterberg Limits</u>	PI=
	LL=	
	<u>Coefficients</u>	
D ₉₀ = 3.0905	D ₈₅ = 0.3475	D ₆₀ =
D ₅₀ =	D ₃₀ =	D ₁₅ =
D ₁₀ =	C _u =	C _c =
	<u>Classification</u>	
USCS= CL	AASHTO=	A-6(11)
	<u>Test Remarks</u>	
Sample visually classified as plastic. Sample rolled below 1/8".		

* (no specification provided)

Source of Sample: Boring Depth: 13-15'
 Sample Number: BB-03 / S-2

Sample Date: 01.16.23

Thielsch Engineering Inc. Cranston, RI	Client: GZA GeoEnvironmental Project: North Street over White Brook Culvert Agawam, MA Project No: 01.0177018.00
Figure 23-S-092	

Tested By: RB / AV Checked By:



Client:	GZA GeoEnvironmental, Inc.		
Project:	North Street Culvert Replace		
Location:	Agawam, MA	Project No:	GTX-316793
Boring ID:	BB-01	Sample Type:	jar
Sample ID:	S-8A	Test Date:	02/17/23
Depth:	18-18.5'	Test Id:	705933
Test Comment:	---		
Visual Description:	Wet, brownish gray silt		
Sample Comment:	---		

Atterberg Limits - ASTM D4318

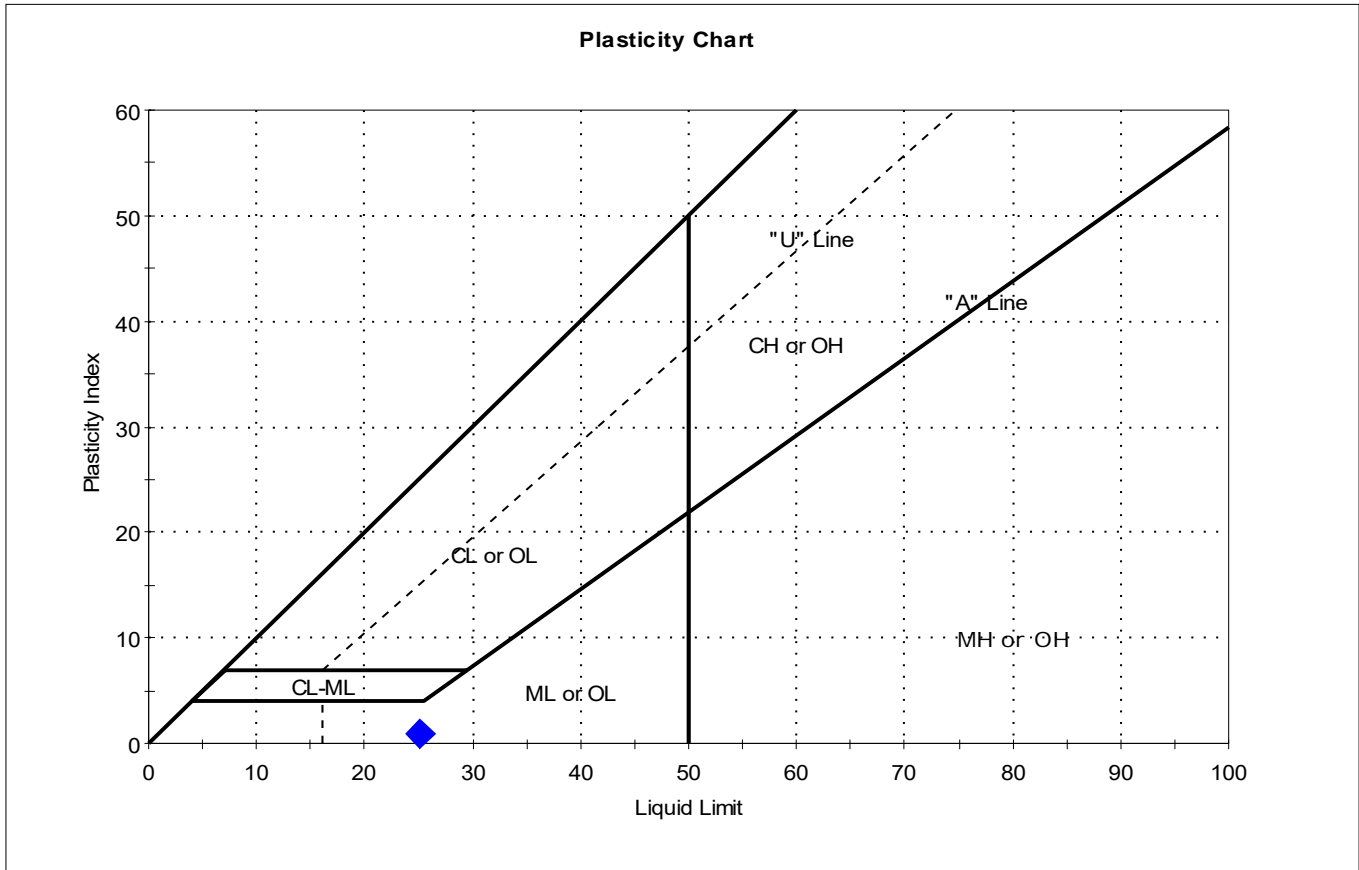

Symbol	Sample ID	Boring	Depth	Natural Moisture Content, %	Liquid Limit	Plastic Limit	Plasticity Index	Liquidity Index	Soil Classification
◆	S-8A	BB-01	18-18.5'	35	25	24	1	11.4	

Sample Prepared using the WET method

Dry Strength: VERY HIGH

Dilatancy: SLOW

Toughness: LOW



Client:	GZA GeoEnvironmental, Inc.		
Project:	North Street Culvert Replace		
Location:	Agawam, MA	Project No:	GTX-316793
Boring ID:	BB-02	Sample Type:	jar
Sample ID:	S-3	Test Date:	02/17/23
Depth :	18-20'	Checked By:	ank
		Test Id:	705934
Test Comment:	---		
Visual Description:	Wet, grayish brown clay		
Sample Comment:	---		

Atterberg Limits - ASTM D4318

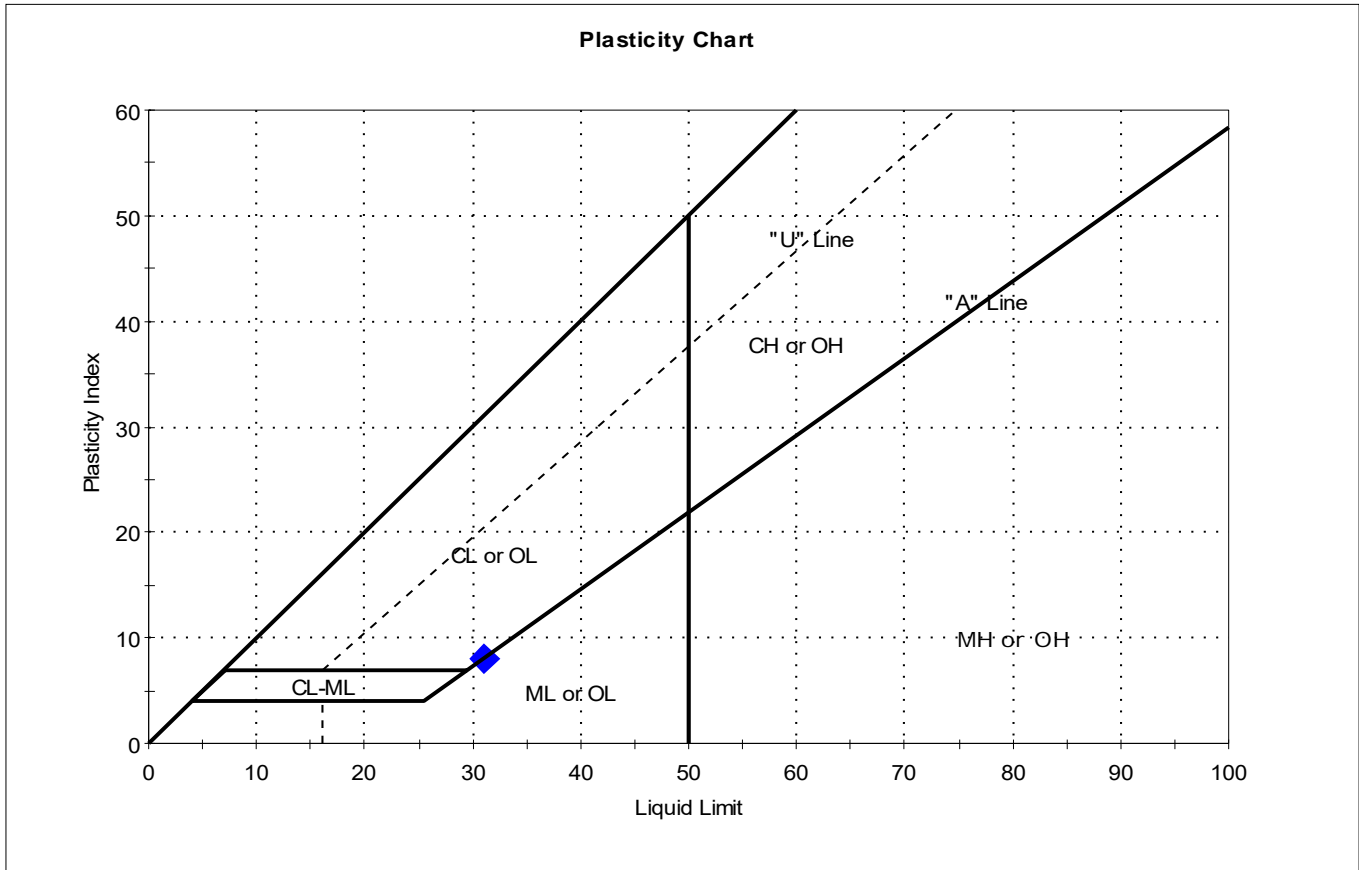

Symbol	Sample ID	Boring	Depth	Natural Moisture Content, %	Liquid Limit	Plastic Limit	Plasticity Index	Liquidity Index	Soil Classification
◆	S-3	BB-02	18-20'	38	31	23	8	1.9	

Sample Prepared using the WET method

Dry Strength: HIGH
 Dilatancy: SLOW
 Toughness: LOW



Client:	GZA GeoEnvironmental, Inc.		
Project:	North Street Culvert Replace		
Location:	Agawam, MA	Project No:	GTX-316793
Boring ID:	BB-02	Sample Type:	jar
Sample ID:	S-5	Test Date:	02/17/23
Depth :	28-30'	Test Id:	705935
Test Comment:	---		
Visual Description:	Wet, brownish gray clay		
Sample Comment:	---		

Atterberg Limits - ASTM D4318

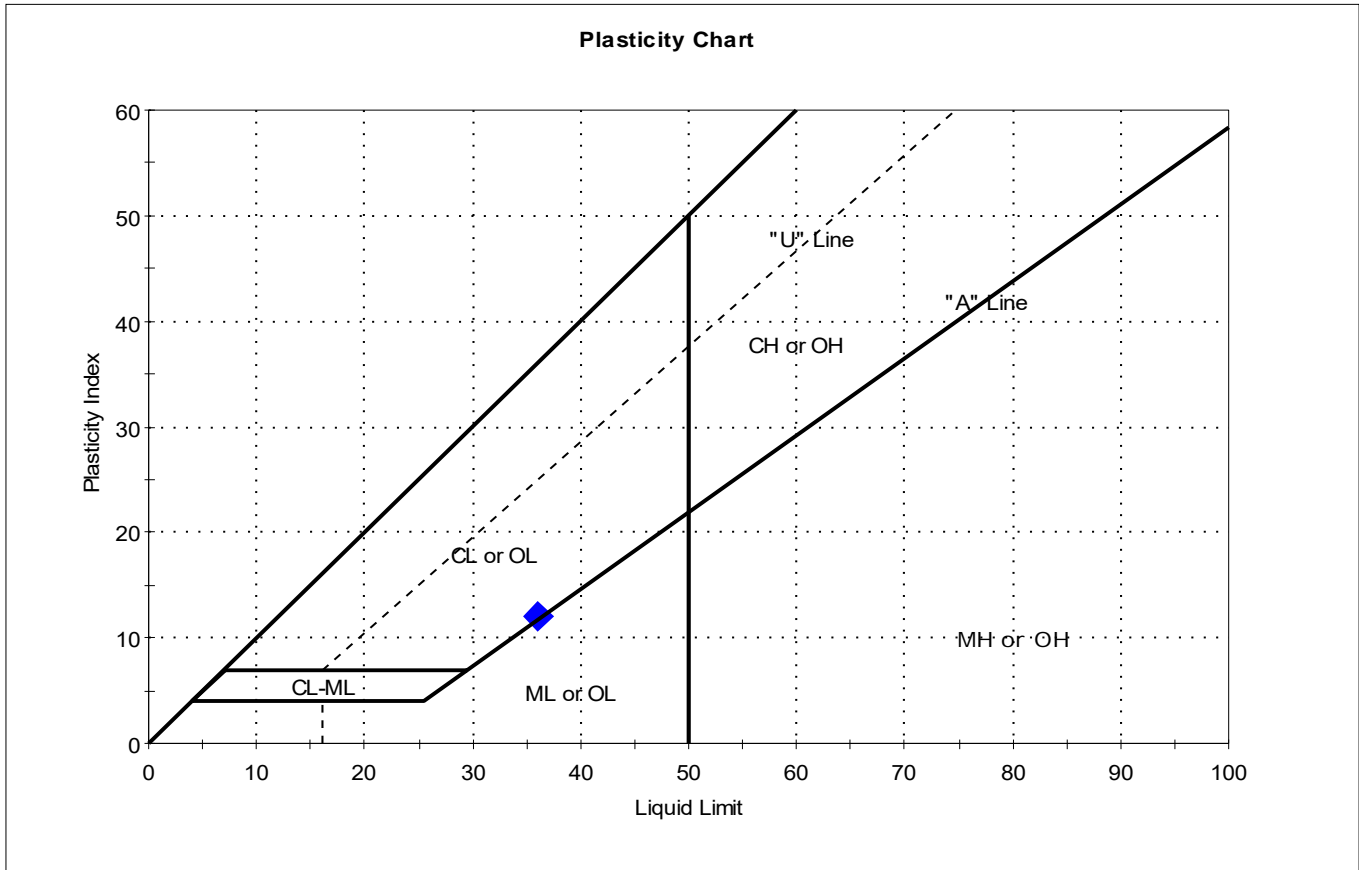

Symbol	Sample ID	Boring	Depth	Natural Moisture Content, %	Liquid Limit	Plastic Limit	Plasticity Index	Liquidity Index	Soil Classification
◆	S-5	BB-02	28-30'	40	36	24	12	1.3	

Sample Prepared using the WET method

Dry Strength: HIGH

Dilatancy: SLOW

Toughness: LOW



Client:	GZA GeoEnvironmental, Inc.		
Project:	North Street Culvert Replace		
Location:	Agawam, MA	Project No:	GTX-316793
Boring ID:	BB-02	Sample Type:	jar
Sample ID:	S-7	Test Date:	02/17/23
Depth :	38-40'	Checked By:	ank
		Test Id:	705936
Test Comment:	---		
Visual Description:	Wet, brownish gray clay		
Sample Comment:	---		

Atterberg Limits - ASTM D4318

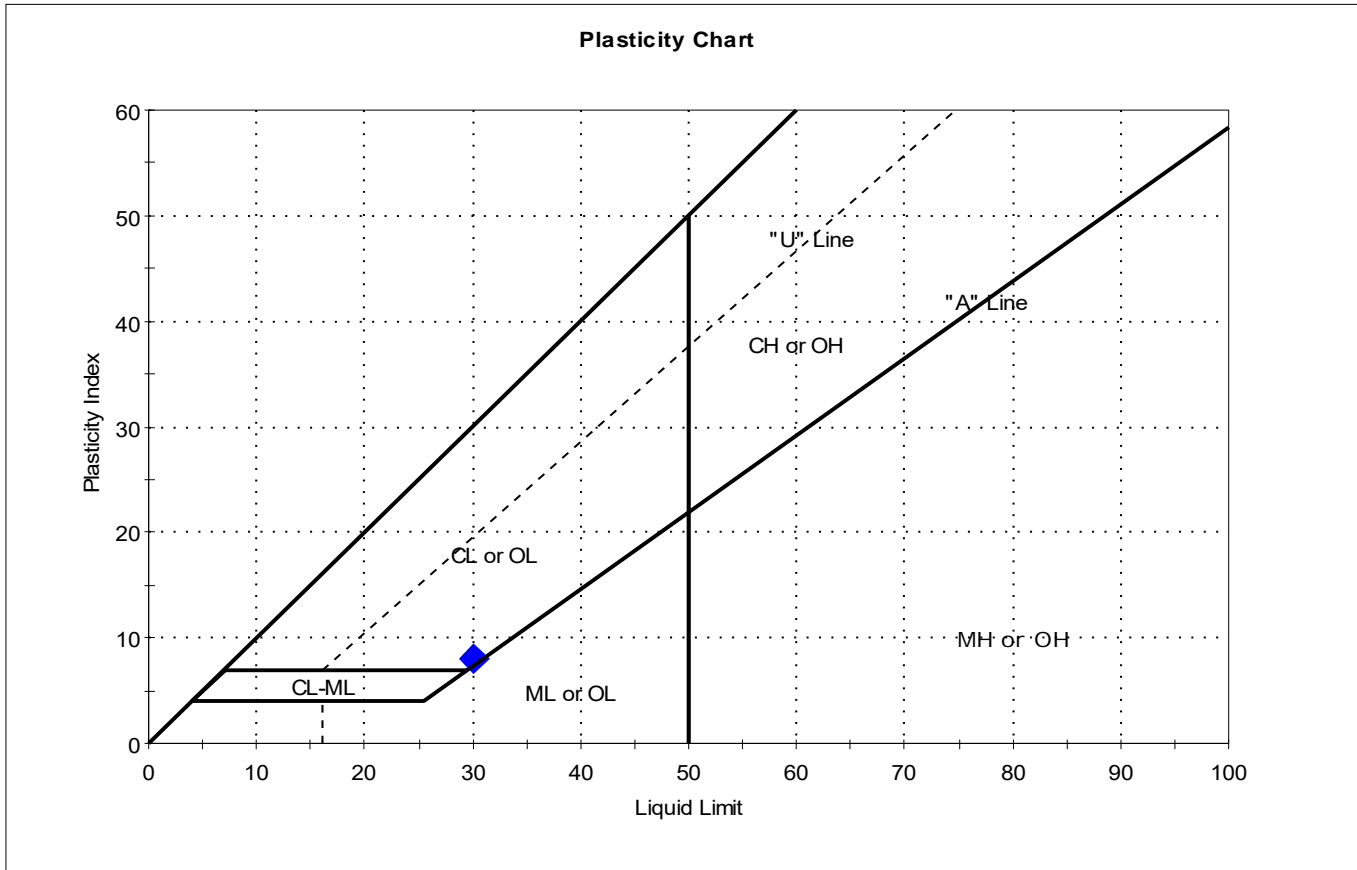

Symbol	Sample ID	Boring	Depth	Natural Moisture Content, %	Liquid Limit	Plastic Limit	Plasticity Index	Liquidity Index	Soil Classification
◆	S-7	BB-02	38-40'	40	30	22	8	2.3	

Sample Prepared using the WET method

Dry Strength: n/a

Dilatancy: n/a

Toughness: n/a



Client:	GZA GeoEnvironmental, Inc.		Project No:	GTX-316793	
Project:	North Street Culvert Replace		Tested By:	cam	
Location:	Agawam, MA	Sample Type:	jar	Checked By:	ank
Boring ID:	BB-03	Test Date:	02/17/23	Test Id:	705938
Sample ID:	S-3	Visual Description:	Wet, grayish brown clay		
Depth :	23-25'	Sample Comment:	---		

Atterberg Limits - ASTM D4318

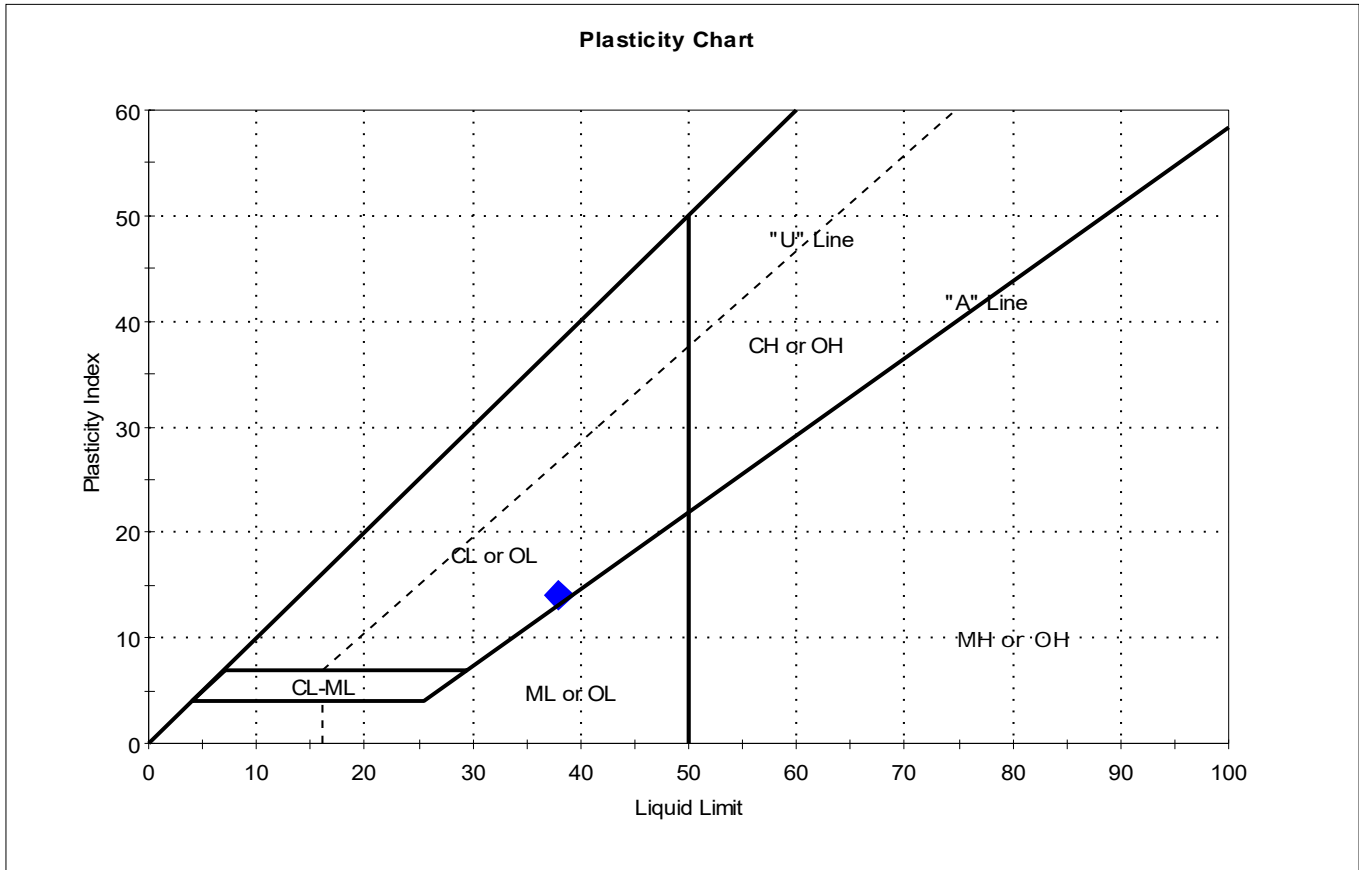

Symbol	Sample ID	Boring	Depth	Natural Moisture Content, %	Liquid Limit	Plastic Limit	Plasticity Index	Liquidity Index	Soil Classification
◆	S-3	BB-03	23-25'	47	38	24	14	1.7	

Sample Prepared using the WET method

Dry Strength: HIGH

Dilatancy: SLOW

Toughness: LOW



Client:	GZA GeoEnvironmental, Inc.		
Project:	North Street Culvert Replace		
Location:	Agawam, MA	Project No:	GTX-316793
Boring ID:	BB-02	Sample Type:	jar
Sample ID:	S-9	Test Date:	02/17/23
Depth :	48-50'	Checked By:	ank
		Test Id:	705937
Test Comment:	---		
Visual Description:	Moist, brown clay		
Sample Comment:	---		

Atterberg Limits - ASTM D4318

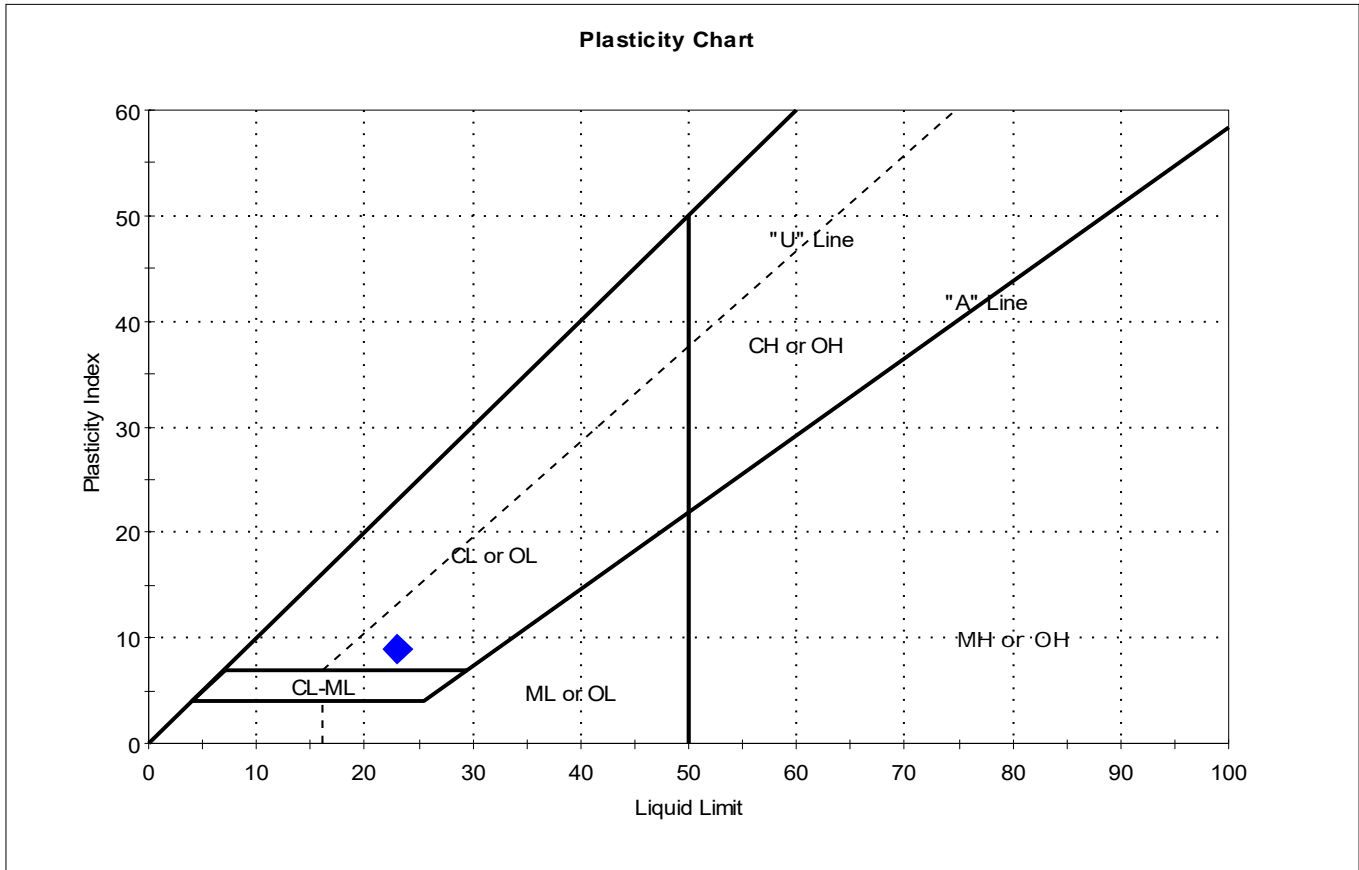

Symbol	Sample ID	Boring	Depth	Natural Moisture Content, %	Liquid Limit	Plastic Limit	Plasticity Index	Liquidity Index	Soil Classification
◆	S-9	BB-02	48-50'	13	23	14	9	-0.1	

Sample Prepared using the WET method

Dry Strength: HIGH

Dilatancy: SLOW

Toughness: LOW



Client:	GZA GeoEnvironmental, Inc.		Project No:	GTX-316793	
Project:	North Street Culvert Replace		Tested By:	cam	
Location:	Agawam, MA	Sample Type:	jar	Checked By:	ank
Boring ID:	BB-03	Test Date:	02/17/23	Test Id:	705939
Sample ID:	S-4	Test Comment: ---			
Depth :	33-35'	Visual Description: Moist, brownish gray clay			
Sample Comment: ---					

Atterberg Limits - ASTM D4318

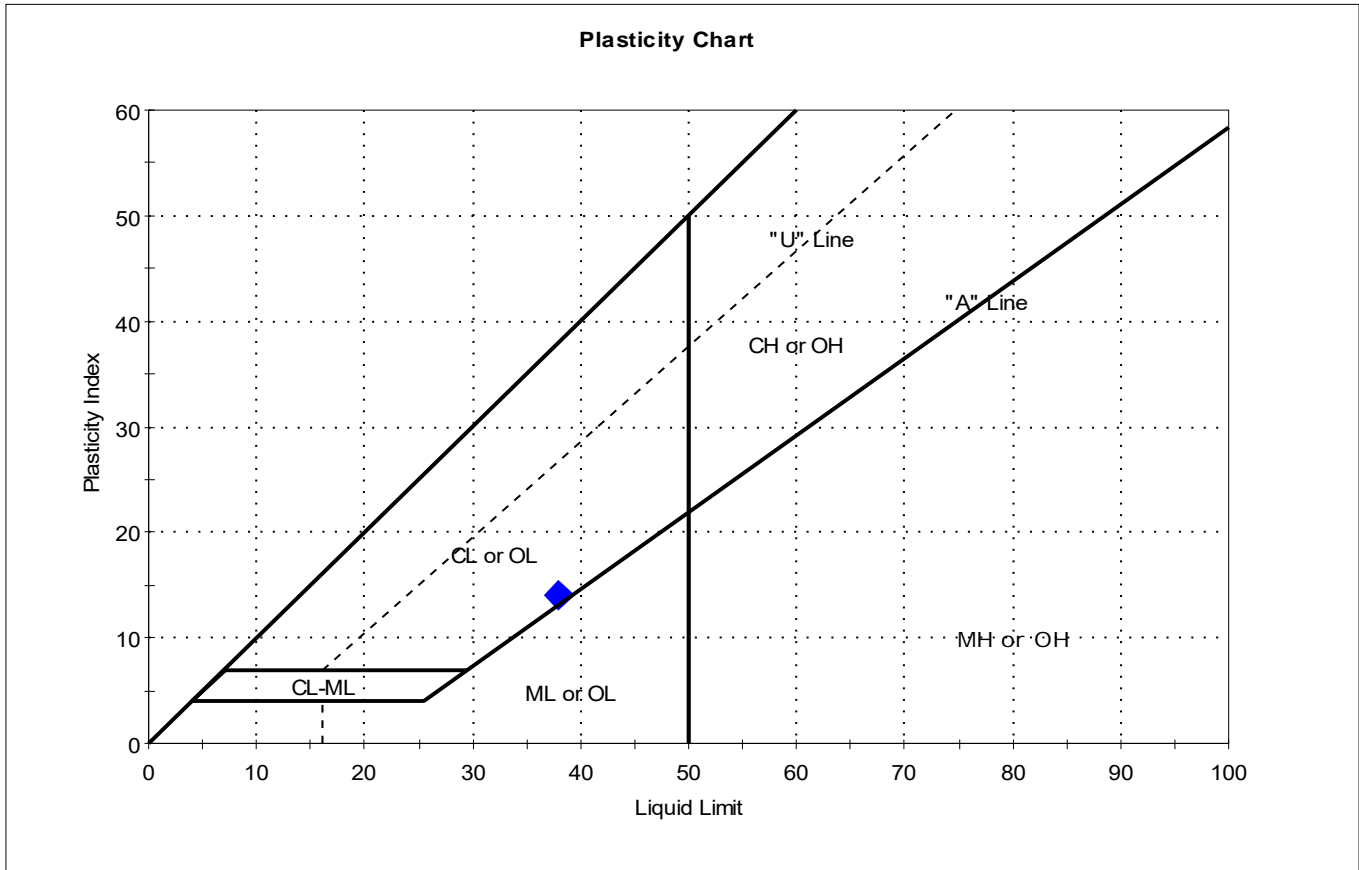

Symbol	Sample ID	Boring	Depth	Natural Moisture Content, %	Liquid Limit	Plastic Limit	Plasticity Index	Liquidity Index	Soil Classification
◆	S-4	BB-03	33-35'	39	38	24	14	1.1	

Sample Prepared using the WET method

Dry Strength: HIGH

Dilatancy: SLOW

Toughness: LOW



Client:	GZA GeoEnvironmental, Inc.		
Project:	North Street Culvert Replace		
Location:	Agawam, MA	Project No:	GTX-316793
Boring ID:	BB-03	Sample Type:	jar
Sample ID:	S-5	Test Date:	02/17/23
Depth :	43-45'	Checked By:	ank
		Test Id:	705940
Test Comment:	---		
Visual Description:	Moist, brown clay		
Sample Comment:	---		

Atterberg Limits - ASTM D4318

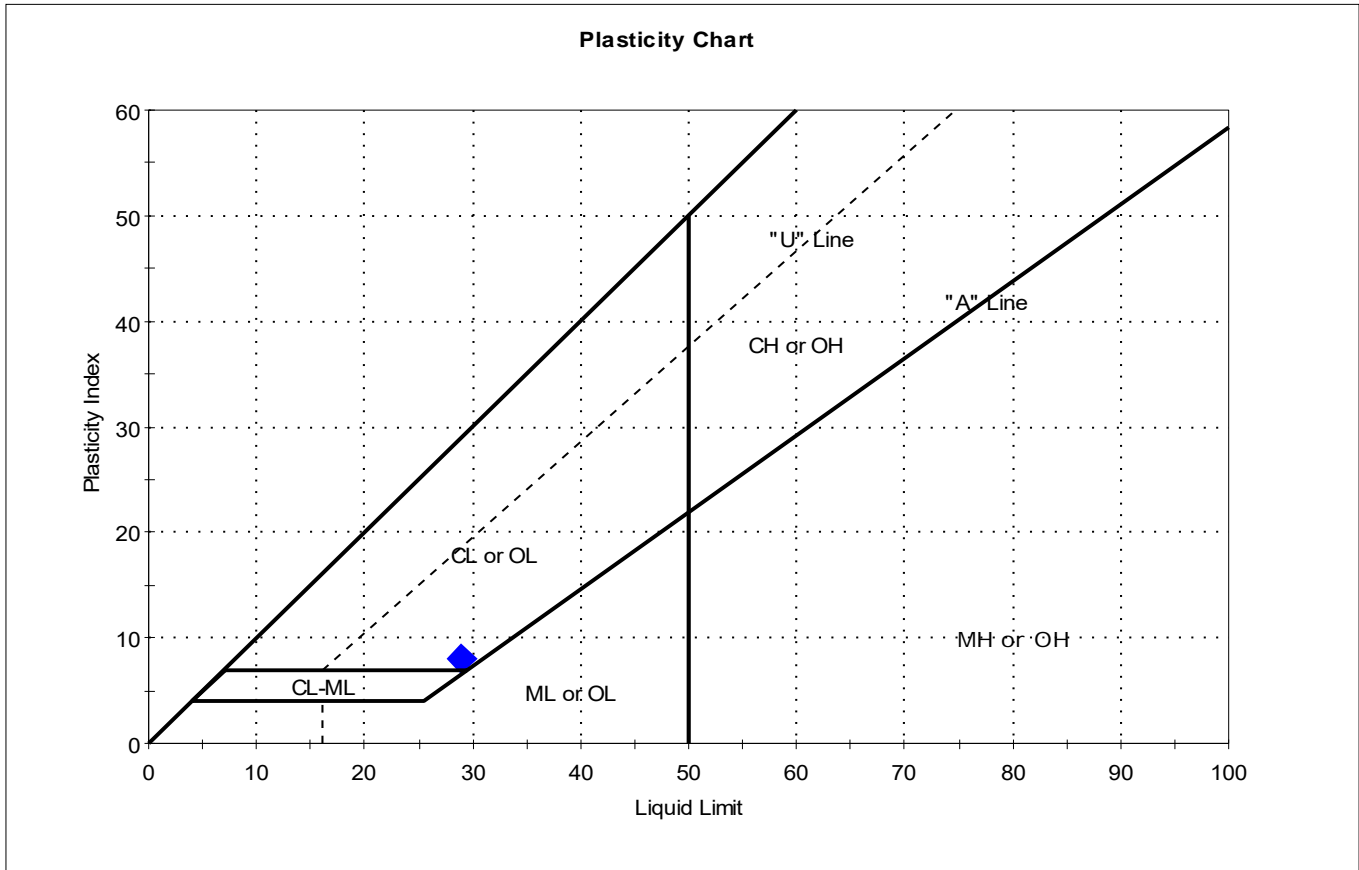

Symbol	Sample ID	Boring	Depth	Natural Moisture Content, %	Liquid Limit	Plastic Limit	Plasticity Index	Liquidity Index	Soil Classification
◆	S-5	BB-03	43-45'	24	29	21	8	0.4	

Sample Prepared using the WET method

Dry Strength: HIGH

Dilatancy: SLOW

Toughness: LOW



APPENDIX G – CALCULATIONS

LRFD Bearing Resistance - North Street over White Brook Culvert Replacement - Abutments



Project:	Culvert Replacement - North Street over White Brook	
Location:	Agawam, MA	
Calculated By:	MJO	Date: 3/30/2023
Checked By:	JBH	Date: 3/30/2023

Purpose: Evaluate factored bearing resistance for the assumed reinforced concrete mat foundation at the new North Street over White Brook culvert using the methodology contained in the AASHTO LRFD Bridge Design Specification, 9th Edition (2020). The proposed culvert is being analyzed as an AASHTO Bridge in accordance with MGL Chapter 85, Section 35 and is anticipated to be a single-span aluminum arch structure with abutment ends supported on a continuous shallow mat foundation bearing on existing natural fine-grained soils.

References: 1) MassDOT Bridge Design Manual, 2013 with 2020 updates.

2) AASHTO LRFD Bridge Design Specifications, 9th Edition, 2020.

3) Subsurface conditions based on recent borings BB-01 through BB-03 completed from December 28 to 30, 2022, by Seaboard Drilling, Inc. of Springfield, Massachusetts, observed and logged by GZA. Subsurface conditions from the recent borings supplemented by subsurface conditions based on previous borings WB-1 and WB-2 completed on November 12, 2020, by Seaboard Drilling, Inc. of Springfield, Massachusetts, observed and logged by O'Rielly, Talbot & Okun.

4) Email from Contech Engineered Solutions LLC transmitted on March 29, 2023 indicating preliminary settlement results by GZA, transmitted 3/24/2023, for the proposed culvert supported by a 22-foot-wide mat foundation are acceptable.

5) Appendix G Attachments 1 and 2 - Preliminary Design Progress Print showing plan and section views of the proposed culvert prepared by Woodard & Curran (W&C), respectively, dated February 16, 2023 with PDF markups by GZA.

Subsurface Conditions: The proposed culvert mat foundation below North Street is assumed to bear at approximately 19.5 to 20 feet below proposed roadway grades (correspond to approximate elevations or El.s ranging from 115 to 116) and slopes upward from north to south based on plans provided by Woodard & Curran dated 2/16/2023. Subsurface conditions at the proposed culvert generally consist of soft to very stiff natural silt & clay. For the purpose of this calculation, assume the bearing stratum is soft natural silt & clay.

Analysis Assumptions: 1) Based on subsurface conditions at the bearing subgrade (soft to very stiff fine-grained soil), use $\phi=0$ degrees for bearing soils. Use a unit weight of 110 pcf.

2) Footings are not considered to be within a slope and considerations for sloping ground conditions are not required for the evaluation of bearing resistance.

3) Perform calculation evaluating proposed roadway (North Street) section of the culvert foundation, 10-ft embedment below the proposed grades, based a cross-section view in Attachment G.2.

4) Based on groundwater levels measured in the 2020 borings during drilling, assume groundwater is at El 121.3 to 122.3 or about 12.7 to 13.7 feet below the proposed roadway grade elevations. Therefore, assume groundwater at about 12.7 feet below the proposed roadway grade elevation.

5) Footing widths (B) for the proposed new culvert are not known at this time. For purpose of this calculation, consider effective footing widths ranging from 15 to 22 feet. 22-foot footing width corresponds to full-width continuous concrete mat slab.

6) Evaluate the factored bearing resistance for the strength limit state. Primary consolidation settlement of the foundation (provided under separate cover) will be used to evaluate the service limit state.

7) Footing length for the proposed culvert, as measured along the longitudinal dimension of the culvert (not including wingwalls), is approximately 119 feet based on the attached plans of Reference #5.

LRFD Bearing Resistance - North Street over White Brook Culvert Replacement - Abutments



Project: Culvert Replacement - North Street over White Brook
Location: Agawam, MA
Calculated By: MJO **Date:** 3/30/2023
Checked By: JBH **Date:** 3/30/2023

Results: The following table summarizes the nominal and factored bearing resistance of the soil anticipated for support of the proposed new culvert for the strength limit state.

Effective Footing Width, B' (ft) (See Note 1)	Nominal Bearing Resistance (ksf)	STRENGTH LIMIT STATE Factored Bearing Resistance (ksf)
15	4.4	2.0
16	4.4	2.0
17	4.4	2.0
18	4.4	2.0
19	4.4	2.0
20	4.4	2.0
21	4.4	2.0
22	4.4	2.0

Selected foundation option

Notes

1. The effective footing width $B'=B-2e$, where e is the eccentricity of the applied footing loads. Per AASHTO LRFD, the maximum permitted eccentricity is one-third of the footing width. The 11-foot footing width corresponds to a full-width continuous concrete mat slab.

Attachments: Bearing Capacity Calculations, Preliminary Design Drawings of proposed culvert with GZA markups (Attachments 1 and 2 of Appendix G), Figures comparing published and recent CVVC Atterberg Limit laboratory test results, Consolidation Settlement & Undrained Shear Strength Estimate calculation files



GZA
GeoEnvironmental, Inc.
 249 Vanderbilt Ave
 Norwood, MA 02062
 781-278-3700

PROJECT: Culvert Replacement - North Street over White Brook
LOCATION: Agawam, MA
CALCULATED BY: MJO **DATE:** 3/30/2023
CHECKED BY: JBH **DATE:** 3/30/2023

<http://www.gza.com>

OBJECTIVE: Evaluate factored net bearing resistance of the proposed foundation for the proposed culvert.

REFERENCE: See cover page.

ASSUMPTIONS AND INPUT

GENERAL ASSUMPTIONS

- See assumptions on calculation package cover page.

ASSUMED SOIL INPUT PARAMETERS

		Basis for Assumption (if applicable)
Soil Unit Weight, γ =	110 pcf	See assumptions
Friction Angle, ϕ =	0 degrees	See assumptions
Cohesion Bearing Capacity Factor, N_c =	5.1	AASHTO LRFD Table 10.6.3.1.2a-1
Embedment Bearing Capacity Factor, N_q =	1.0	AASHTO LRFD Table 10.6.3.1.2a-1
Unit Weight Bearing Capacity Factor, N_γ =	0.0	AASHTO LRFD Table 10.6.3.1.2a-1
Poisson's Ratio, ν =	0.40	AASHTO LRFD Table C10.4.6.3-1
Young's Modulus, E_s =	1.74 ksi	AASHTO LRFD Table C10.4.6.3-1
Cohesion, c =	500 psf	Refer to Undrained Shear Strength Estimate attachment
Depth to Groundwater, D_w =	12.7 ft	See cover page assumptions

ASSUMED FOOTING PARAMETERS

		Basis for Assumption (if applicable)
Footing Length, L =	119 ft	See cover page assumptions
Footing Embedment Depth, D_f =	19.5 ft	See cover page assumptions
Footing Eccentricity, e =	varies ft	See cover page assumptions

ASSUMED BEARING RESISTANCE FACTOR

		Basis for Assumption (if applicable)
Bearing Resistance Factor, ϕ_b =	0.45	AASHTO LRFD Table 10.5.5.2.2-1

Note: for the extreme limit state, use a resistance factor of 1.0 (AASHTO 10.5.5.3.3), i.e. $qr = qn$

DESIRED OUTPUT

Enter up to 15 Footing Widths for calculation, in ascending order. Leave unused cells blank.

	1	2	3	4	5	6	7	8
Effective Footing Width, B' (ft)	15	16	17	18	19	20	21	22



GZA
GeoEnvironmental, Inc.
 249 Vanderbilt Ave
 Norwood, MA 02062
 781-278-3700

<http://www.gza.com>

PROJECT: Culvert Replacement - North Street over White Brook
LOCATION: Agawam, MA
CALCULATED BY: MJO **DATE:** 3/30/2023
CHECKED BY: JBH **DATE:** 3/30/2023

CALCULATIONS

- Determine effective footing width, B' , to account for eccentric loading: $B' = B - 2e$ (AASHTO LRFD Eqn 10.6.1.3-1)
- Account for groundwater using factors C_{wq} and C_{wy} using AASHTO LRFD Table 10.6.3.1.2a-2
- Shape Correction Factors s_c , s_γ , and s_q determined using equation in AASHTO LRFD Table 10.6.3.1.2a-3
- Depth Correction Factor d_q estimated using AASHTO LRFD Equation 10.6.3.1.2a-10
- Load inclination factors i_c , i_γ , and i_q conservatively assumed to be 1.0 based on unknown loading conditions
- Nominal Bearing Resistance, q_n , determined using AASHTO LRFD Equation 10.6.3.1.2a-1

$$q_n = cN_{cm} + \gamma D_f N_{qm} C_{wq} + 0.5 \gamma B' N_{ym} C_{wy}$$
 where: $N_{qm} = N_q s_q d_q i_q$
 $N_{ym} = N_\gamma s_\gamma i_\gamma$
 $N_{cm} = N_c s_c i_c$
- Factored Bearing Resistance, q_r , estimated using AASHTO LRFD Equation 10.6.3.1.1-1: $q_r = q_n \phi_b$
- Sloping ground conditions accounted for (if applicable) using correction factor RC_{BC} developed in accordance with AASHTO LRFD 10.6.3.1.2c. If no correction use $RCBC = 1$.

DETERMINE FACTORED BEARING RESISTANCE, q_r

	B' [ft]	B'/L	D_f/B'	C_{wq}	C_{wy}	N_{cq} (if applicable)	N_{cy} (if applicable)	s_c	s_γ	s_q	d_q
	15.0	0.13	1.30	0.83	0.50			1.03	1.00	1.00	1.00
	16.0	0.13	1.22	0.83	0.50			1.03	1.00	1.00	1.00
	17.0	0.14	1.15	0.83	0.50			1.03	1.00	1.00	1.00
	18.0	0.15	1.08	0.83	0.50			1.03	1.00	1.00	1.00
	19.0	0.16	1.03	0.83	0.50			1.03	1.00	1.00	1.00
	20.0	0.17	0.98	0.83	0.50			1.03	1.00	1.00	1.00
	21.0	0.18	0.93	0.83	0.50			1.04	1.00	1.00	1.00
	22.0	0.18	0.89	0.83	0.50			1.04	1.00	1.00	1.00

calculation continued on next page



GZA
GeoEnvironmental, Inc.
 249 Vanderbilt Ave
 Norwood, MA 02062
 781-278-3700

PROJECT: Culvert Replacement - North Street over White Brook
LOCATION: Agawam, MA
CALCULATED BY: MJO **DATE:** 3/30/2023
CHECKED BY: JBH **DATE:** 3/30/2023

<http://www.gza.com>

q_r calculation, continued

B' [ft]	RC _{BC}	N _{qm}	N _{ym}	N _{cm}	q _n [psf]	q _r [psf]
15	1	1.0	0.0	5.3	4,406	1,983
16	1	1.0	0.0	5.3	4,410	1,985
17	1	1.0	0.0	5.3	4,414	1,986
18	1	1.0	0.0	5.3	4,419	1,988
19	1	1.0	0.0	5.3	4,423	1,990
20	1	1.0	0.0	5.3	4,427	1,992
21	1	1.0	0.0	5.3	4,432	1,994
22	1	1.0	0.0	5.3	4,436	1,996

L/B	Bz [unitless]
7.9	1.41
7.4	1.41
7.0	1.38
6.6	1.32
6.3	1.28
6.0	1.25
5.7	1.22
5.4	1.20



FIGURE G.1-1

Atterberg Limit Result Comparison No. G.1-1: Umass Amherst (2003) vs. Recent (2023) Results

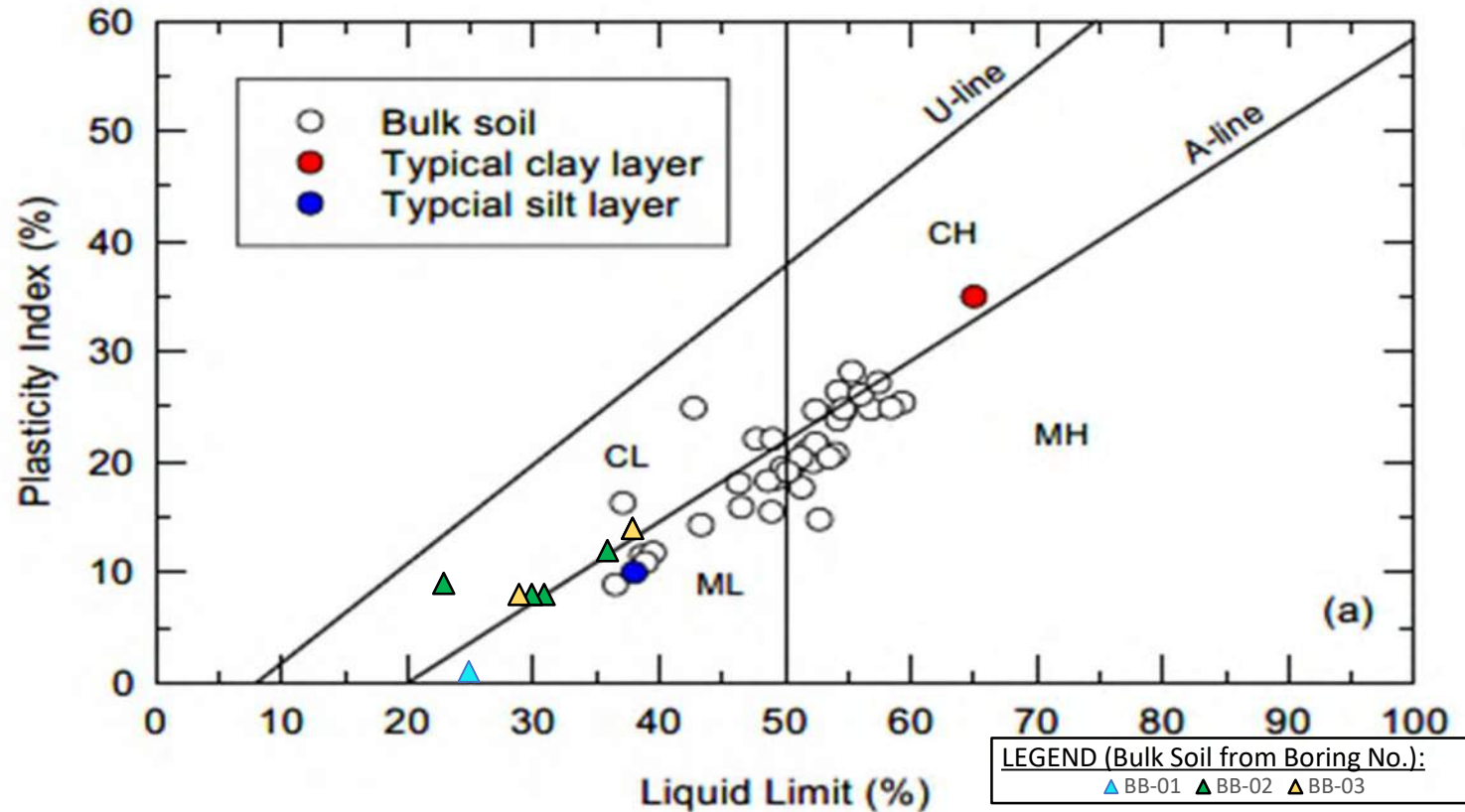

- Notes: 1) Recent borings BB-01 through BB-03 performed between December 28 and 30, 2022 by Seaboard Drilling, Inc., observed and logged by GZA.
2) Laboratory results for BB-01 through BB-03 prepared by GeoTesting Express dated 2/17/2023.

Source Document: Degroot, D.J., & Lutenegeger, A.J. (2003). "Engineering Properties of Connecticut Valley Varved Clay."



FIGURE G.1-2

Atterberg Limit Result Comparison No. G.1-2: Umass Amherst (2003) vs. Recent (2023) Results

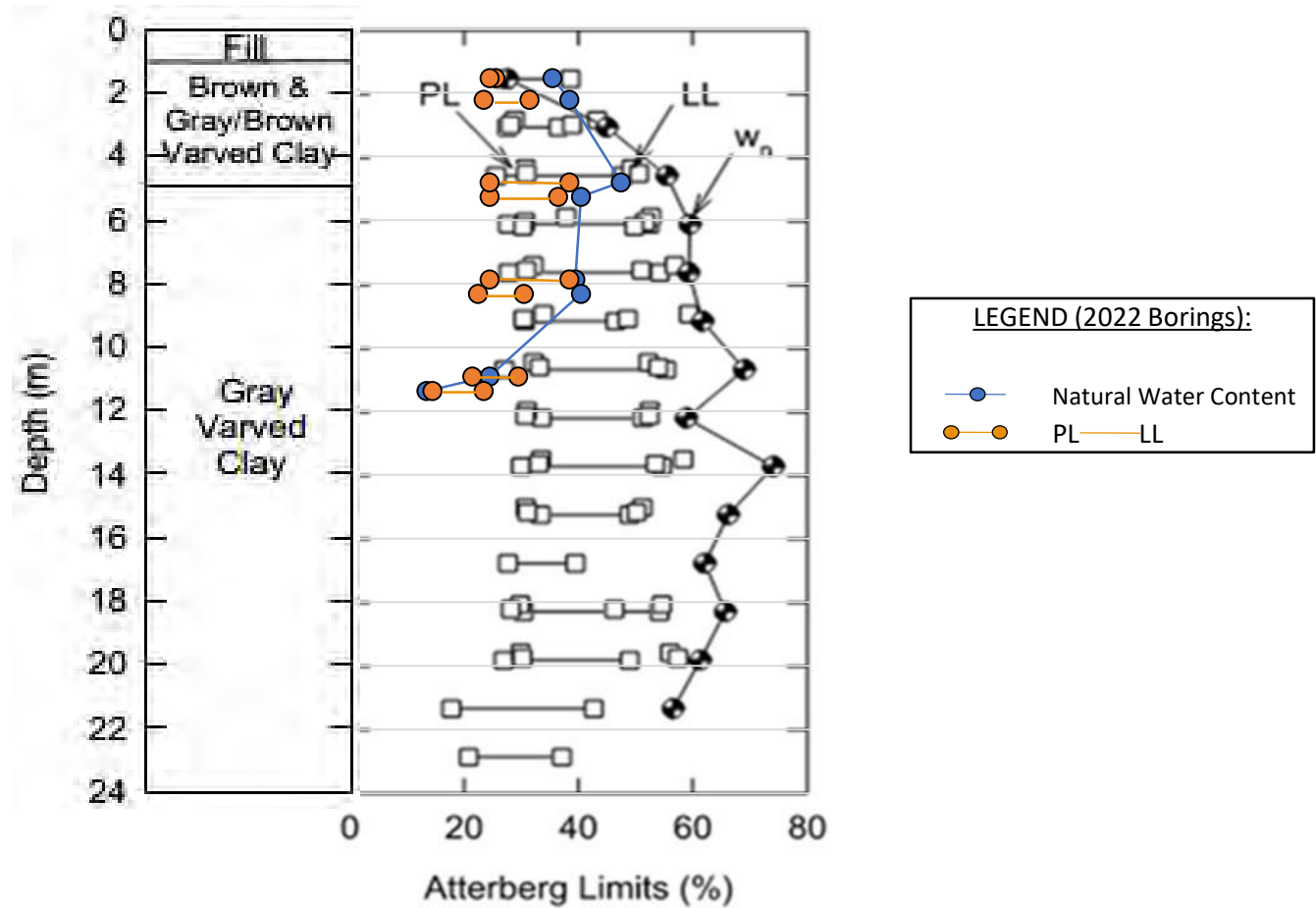

- Notes:
- 1) Recent borings BB-01 through BB-03 performed between December 28 and 30, 2022 by Seaboard Drilling, Inc., observed and logged by GZA.
 - 2) Laboratory results for BB-01 through BB-03 prepared by GeoTesting Express dated 2/17/2023. The depths of the 2023 results were corrected to reduce the fill thickness to 1 meter for the purpose of the comparison.
 - 3) Abbreviations: Wn = Natural Water content, PL = Plastic Limit, LL = Liquid Limit.

Source Document: Degroot, D.J., & Lutenegeger, A.J. (2003). "Engineering Properties of Connecticut Valley Varved Clay."

Estimated Footing Reactions & Applied Bearing Pressures - Proposed Culvert at North Street over White Brook Proposed Culvert



Project: Culvert Replacement - North Street over White Brook
Location: Agawam, MA
Calculated By: MJO **Date:** 4/11/2023
Checked By: MAR **Date:** 4/11/2023

Purpose: To estimate unfactored footing reaction loads for the proposed footings at the North Street over White Brook replacement culvert using the methodology in accordance with MassDOT LRFD Bridge Design Manual, which references the AASHTO LRFD Bridge Design Specification, 9th Edition (2020). The proposed culvert is anticipated to be a single-span aluminum structural plate single radius arch structure with abutment ends supported on a shallow foundation bearing on existing natural fine-grained soils. The three culvert sections to be evaluated are designated areas: C1 - the upstream 1/3, C2 - the middle 1/3, and C3 - the downstream 1/3.

- References:**
- 1) MassDOT Bridge Design Manual, 2013 with 2020 updates.
 - 2) AASHTO LRFD Bridge Design Specifications, 9th Edition, 2020.
 - 3) Subsurface conditions based on recent borings BB-01 through BB-03 completed from December 28 to 30, 2022, by Seaboard Drilling, Inc. of Springfield, Massachusetts, observed and logged by GZA. Subsurface conditions from the recent borings supplemented by subsurface conditions based on previous borings WB-1 and WB-2 completed on November 12, 2020, by Seaboard Drilling, Inc. of Springfield, Massachusetts, observed and logged by O’Rielly, Talbot & Okun.
 - 4) Email from Woodard & Curran (W&C) with calculations prepared by Contech Engineered Solutions LLC (Contech) for Structural Plate Footing Reactions per AASHTO Standard Specification for Highway Bridges, Section 12, dated February 15, 2023.
 - 5) Appendix G Attachments 1 and 2 - Preliminary Design Progress Print showing plan and section views of the proposed culvert prepared by Woodard & Curran (W&C), respectively, dated February 16, 2023 with PDF markups by GZA.

Subsurface Conditions: Proposed top of culvert elevations for settlement evaluation area Nos. C1, C2, and C3 are depicted as ranging between approximately 10 and 19.5 feet below the proposed North Street culvert area replacement grades in the longitudinal culvert profile view prepared by W&C of sheet C-102 entitled "Site Layout Plan," dated February 2023.

Analysis: 1) Culvert dimensions and location as depicted in Reference #5.

- Assumptions:**
- 2) Culvert foundation assumed to be a 22-foot-wide continuous mat foundation as depicted in Reference #5.
 - 3) Fill materials over the proposed culvert and culvert foundation: Compacted expanded shale lightweight aggregate (ES-LWA, assumed unit weight of 70 pounds per cubic foot [pcf]) fill to between approximately 1- to 1.5-feet above the proposed culvert, compacted ultra-lightweight foamed glass aggregate (UL-FGA, assumed unit weight of 25 pcf) fill on top of the ES-LWA to between 1- and 1.5-feet from proposed ground surface level and 1 to 1.5 feet of compacted normal-weight (NW, assumed unit weights of 118 and 125 pcf for topsoil and granular fill/asphalt, respectively) granular fill to proposed ground surface level.
 - 4) Evaluate vehicular live loads for the footing reactions assuming HL-93 tandem vehicle loading. Per AASHTO Figure C12.8.4.2-1, vehicular live loads (LLs) calculated are adjusted based on the lateral distance of the Culvert Area to the LL (overlapping two and single vehicle load conditions assumed to extend to approx. 31 and 44 feet from the North Street centerline, respectively).
 - 5) Neglect the effects of the loose 2-foot-thick streambed cover material over the proposed culvert footings.

Results: The following table summarizes the unfactored vertical dead and live loads per footing section area for the proposed culvert at North Street over White Brook:

Culvert Area ID - Description	Calculation No.	Vert. Dead Load, DL (k / ft / footing)	Vert. Live Load, LL (k / ft / footing)	Total Load: DL + LL (k / ft / footing)	Avg. Bearing Pressure over 22-ft mat foundation, DL (ksf)	Avg. Bearing Pressure over 22-ft mat foundation, DL+LL (ksf)
C1 - Upstream (Low side)	DL-1L	4.5	0.0	4.5	0.51	0.52
C1 - Upstream (High side)	DL+LL-1H	6.7	0.2	6.9		
C2 - Mid-length (Low side)	DL+LL-2L	5.3	2.2	7.5	0.49	0.69
C2 - Mid-length (High side)	DL+LL-2H	5.5	2.1	7.6		
C3 - Downstream (Low side)	DL-3L	4.8	0.0	4.8	0.54	0.59
C3 - Downstream (High side)	DL+LL-3H	7.2	1.1	8.2		

LRFD Load Factors for DL, LL (from AASHTO LRFD Tables 3.4.1-2 & 3.4.1-1, respectively) = 1.5, 1.75
 Factored Avg. Bearing Pressure over 22-ft mat foundation at highest load combination Area, Calc No. DL+LL-3H (ksf) = 1.1
 Factored Bearing Resistance from GZA Calculation (ksf) = 2.0
 Factored Bearing Resistance > Calculated Avg. Bearing Pressure? Yes

Attachments: Calculations by GZA, Calculations by Contech, Preliminary Design Drawings of proposed culvert with GZA markups (Attachments 1 and 2 of Appendix G)



GZA
GeoEnvironmental, Inc.
 249 Vanderbilt Ave
 Norwood, MA 02062
 781-278-3700
<http://www.gza.com>

CALCULATION NO. DL-1L

PROJECT: Culvert Replacement - North Street over White Brook
 LOCATION: Agawam, MA
 CALCULATED BY: MJO DATE: 4/11/2023
 CHECKED BY: MAR DATE: 4/11/2023

OBJECTIVE: Evaluate unfactored dead load (DL) footing reactions of the North Street over White Brook proposed culvert replacement **at the approximate low point of settlement evaluation area No. C1.**

REFERENCE: See cover.

ASSUMPTIONS AND INPUT

GENERAL ASSUMPTIONS

- See assumptions on calculation package cover page.

Culvert Shape =	ALSP 18'0" Span x 7'-8" Rise		Reference #3 of cover page
Span (S) =	18	ft	Reference #3 of cover page
Total Lateral footing projection beyond culvert span (L _{FP}) =	4	ft	See cover page assumptions for foundation width
Arch Top Rise (Rt) =	7.7	ft	Reference #3 of cover page
Bottom Span =	18.0	ft	Reference #3 of cover page
Area of Top Rise (At) =	104.5	sq ft	Reference #3 of cover page
Footing contact angle (fca) =	8.94	degrees	Reference #3 of cover page
Total Height of Cover (Ht) =	10	ft	Reference #4
Height of Cover over Culvert (H) =	2.3	ft	See cover page assumptions
Axle Load Type =	0	lbs	Reference #3 of cover page
Number of Lanes =	0		Reference #4
Axle Load (AL) =	0	lbs	Reference #3 of cover page
ES-LWA Soil Density (γ_{ES-LWA}) =	70	pcf	See cover page assumptions
Height of ES-LWA fill cover over Culvert (H _{ES-LWA}) =	1.3	ft	See cover page assumptions
UL-FGA Soil Density (γ_{UL-FGA}) =	25	pcf	See cover page assumptions
Height of UL-FGA fill cover over Culvert (H _{UL-FGA}) =	0	ft	See cover page assumptions
Topsoil Soil Density (γ_{NW}) =	118	pcf	See cover page assumptions, topsoil
Height of Normal Weight fill cover over Culvert (H _{NW}) =	1	ft	See cover page assumptions

LOAD ON STRUCTURE

Live Load

$$\text{Live Load, LL} = \frac{AL}{(8 + 2(H + Rt))} / 1000$$

$$\text{Live Load} = \frac{0}{} \text{ kips / ft per footing}$$

Dead Load

$$\text{Dead Load, DL} = \frac{\text{Weight of Soil overlying Culvert Footing}}{}$$

Weighted area average for Soil Unit Weight

$$\text{Cross-sectional area of ES-LWA over Culvert (A}_{ES-LWA}) = \frac{(S + L_{FP}) \times (Rt + H_{ES-LWA}) - At}{}$$

$$\text{Cross-sectional area of ES-LWA over Culvert (A}_{ES-LWA}) = \frac{92.8}{} \text{ sq ft}$$

$$\text{Cross-sectional area of UL-FGA over Culvert (A}_{UL-FGA}) = \frac{H_{UL-FGA} \times (S + L_{FP})}{}$$

$$\text{Cross-sectional area of UL-FGA over Culvert (A}_{UL-FGA}) = \frac{0.0}{} \text{ sq ft}$$

$$\text{Cross-sectional area of NW fill over Culvert (A}_{NW}) = \frac{H_{NW} \times (S + L_{FP})}{}$$

$$\text{Cross-sectional area of NW fill over Culvert (A}_{NW}) = \frac{22}{} \text{ sq ft}$$

Weighted Soil Unit Weight

$$\text{Weighted Soil Density (ES-LWA, UL-FGA and NW Fills)} = \frac{(\gamma_{UL-FGA} \times A_{UL-FGA} + \gamma_{ES-LWA} \times A_{ES-LWA} + \gamma_{NW} \times (A_{NW}))}{(A_{UL-FGA} + A_{ES-LWA} + A_{NW})}$$

$$\text{Weighted Soil Density (ES-LWA, UL-FGA and NW Fills)} = \frac{79.2}{} \text{ pcf}$$

Soil Weight

$$\text{Soil Weight} = \frac{((S + L_{FP}) \times (H + Rt) - At) \times \text{Weighted Soil Density}}{1000 \text{ lb/kip}}$$

$$\text{Soil Weight} = \frac{9.1}{} \text{ kips / ft}$$

$$\text{Dead Load} = \frac{4.6}{} \text{ kips / ft per footing}$$

Total Load

$$\text{Total Load, V} = \frac{\text{Live Load} + \text{Dead Load}}{}$$

$$\text{Total Load, V} = \frac{4.6}{} \text{ kips / ft per footing}$$



GZA
GeoEnvironmental, Inc.
 249 Vanderbilt Ave
 Norwood, MA 02062
 781-278-3700
<http://www.gza.com>

CALCULATION NO. DL-1L

PROJECT: Culvert Replacement - North Street over White Brook
 LOCATION: Agawam, MA
 CALCULATED BY: MJO DATE: 4/11/2023
 CHECKED BY: MAR DATE: 4/11/2023

OBJECTIVE: Evaluate unfactored dead load (DL) footing reactions of the North Street over White Brook proposed culvert replacement **at the approximate low point of settlement evaluation area No. C1.**

REFERENCE: See cover.

FOOTING REACTIONS

Vertical

$R_V =$	<u> V x cos(fca)</u>	
$R_{V,LL} =$	<u> 0.0</u>	kips / ft per footing
$R_{V,DL} =$	<u> 4.5</u>	kips / ft per footing
$R_V \text{ Total} =$	<u> 4.5</u>	kips / ft per footing

Horizontal

$R_H =$	<u> V x sin(fca)</u>	
$R_{H,LL} =$	<u> 0.0</u>	kips / ft per footing
$R_{H,DL} =$	<u> 0.7</u>	kips / ft per footing
$R_H \text{ Total} =$	<u> 0.7</u>	kips / ft per footing <u>outward</u>



GZA
GeoEnvironmental, Inc.
 249 Vanderbilt Ave
 Norwood, MA 02062
 781-278-3700
<http://www.gza.com>

CALCULATION NO. DL+LL-1H

PROJECT: Culvert Replacement - North Street over White Brook
 LOCATION: Agawam, MA
 CALCULATED BY: MJO DATE: 4/11/2023
 CHECKED BY: MAR DATE: 4/11/2023

OBJECTIVE: Evaluate unfactored dead and live load (DL and LL, respectively) footing reactions of the North Street over White Brook proposed culvert replacement **at the approximate high point of settlement evaluation area No. C1.**

REFERENCE: See cover.

ASSUMPTIONS AND INPUT

GENERAL ASSUMPTIONS

- See assumptions on calculation package cover page.

Culvert Shape =	ALSP 18'0" Span x 7'-8" Rise		Reference #3 of cover page
Span (S) =	18	ft	Reference #3 of cover page
Total Lateral footing projection beyond culvert span (L _{FP}) =	4	ft	See cover page assumptions for foundation width
Arch Top Rise (Rt) =	7.7	ft	Reference #3 of cover page
Bottom Span =	18.0	ft	Reference #3 of cover page
Area of Top Rise (At) =	104.5	sq ft	Reference #3 of cover page
Footing contact angle (fca) =	8.94	degrees	Reference #3 of cover page
Total Height of Cover (Ht) =	18.5	ft	Reference #4
Height of Cover over Culvert (H) =	10.8	ft	See cover page assumptions
Axle Load Type =	Tandem (HL-93)	lbs	Reference #3 of cover page
Number of Lanes =	1		Reference #4
Axle Load (AL) =	50,000	lbs	Reference #3 of cover page
ES-LWA Soil Density (γ_{ES-LWA}) =	70	pcf	See cover page assumptions
Height of ES-LWA fill cover over Culvert (H _{ES-LWA}) =	1	ft	See cover page assumptions
UL-FGA Soil Density (γ_{UL-FGA}) =	25	pcf	See cover page assumptions
Height of UL-FGA fill cover over Culvert (H _{UL-FGA}) =	8.8	ft	See cover page assumptions
Topsoil Soil Density (γ_{NW}) =	118	pcf	See cover page assumptions, topsoil
Height of Normal Weight fill cover over Culvert (H _{NW}) =	1	ft	See cover page assumptions

LOAD ON STRUCTURE

Live Load

$$\text{Live Load, LL} = \frac{AL}{(8 + 2(H + Rt))} / 1000$$

$$\text{Live Load} = \frac{0.2}{\text{}} \text{ kips / ft per footing}$$

Dead Load

$$\text{Dead Load, DL} = \text{Weight of Soil overlying Culvert Footing}$$

Weighted area average for Soil Unit Weight

$$\text{Cross-sectional area of ES-LWA over Culvert (A}_{ES-LWA}) = \frac{(S + L_{FP}) \times (Rt + H_{ES-LWA}) - A_t}{\text{}}$$

$$\text{Cross-sectional area of ES-LWA over Culvert (A}_{ES-LWA}) = \frac{86.2}{\text{}} \text{ sq ft}$$

$$\text{Cross-sectional area of UL-FGA over Culvert (A}_{UL-FGA}) = \frac{H_{UL-FGA} \times (S + L_{FP})}{\text{}}$$

$$\text{Cross-sectional area of UL-FGA over Culvert (A}_{UL-FGA}) = \frac{194.3}{\text{}} \text{ sq ft}$$

$$\text{Cross-sectional area of NW fill over Culvert (A}_{NW}) = \frac{H_{NW} \times (S + L_{FP})}{\text{}}$$

$$\text{Cross-sectional area of NW fill over Culvert (A}_{NW}) = \frac{22}{\text{}} \text{ sq ft}$$

Weighted Soil Unit Weight

$$\text{Weighted Soil Density (ES-LWA, UL-FGA and NW Fills)} = \frac{(\gamma_{UL-FGA} \times A_{UL-FGA} + \gamma_{ES-LWA} \times A_{ES-LWA} + \gamma_{NW} \times (A_{NW}))}{(A_{UL-FGA} + A_{ES-LWA} + A_{NW})}$$

$$\text{Weighted Soil Density (ES-LWA, UL-FGA and NW Fills)} = \frac{44.6}{\text{}} \text{ pcf}$$

Soil Weight

$$\text{Soil Weight} = \frac{((S + L_{FP}) \times (H + Rt) - A_t) \times \text{Weighted Soil Density}}{1000 \text{ lb/kip}}$$

$$\text{Soil Weight} = \frac{13.5}{\text{}} \text{ kips / ft}$$

$$\text{Dead Load} = \frac{6.7}{\text{}} \text{ kips / ft per footing}$$

Total Load

$$\text{Total Load, V} = \frac{\text{Live Load} + \text{Dead Load}}{\text{}}$$

$$\text{Total Load, V} = \frac{7.0}{\text{}} \text{ kips / ft per footing}$$



GZA
GeoEnvironmental, Inc.
 249 Vanderbilt Ave
 Norwood, MA 02062
 781-278-3700
<http://www.gza.com>

CALCULATION NO. DL+LL-1H

PROJECT: Culvert Replacement - North Street over White Brook
 LOCATION: Agawam, MA
 CALCULATED BY MJO DATE 4/11/2023
 CHECKED BY MAR DATE 4/11/2023

OBJECTIVE: Evaluate unfactored dead and live load (DL and LL, respectively) footing reactions of the North Street over White Brook proposed culvert replacement **at the approximate high point of settlement evaluation area No. C1.**

REFERENCE: See cover.

FOOTING REACTIONS

Vertical

$R_V =$	<u> </u>	<u> </u>	
	$V \times \cos(fca)$		
$R_{V,LL} =$	<u>0.2</u>		kips / ft per footing
$R_{V,DL} =$	<u>6.7</u>		kips / ft per footing
$R_V \text{ Total} =$	<u>6.9</u>		kips / ft per footing

Horizontal

$R_H =$	<u> </u>	<u> </u>	
	$V \times \sin(fca)$		
$R_{H,LL} =$	<u>0.0</u>		kips / ft per footing
$R_{H,DL} =$	<u>1.0</u>		kips / ft per footing
$R_H \text{ Total} =$	<u>1.1</u>		kips / ft per footing <u>outward</u>



GZA
GeoEnvironmental, Inc.
 249 Vanderbilt Ave
 Norwood, MA 02062
 781-278-3700
<http://www.gza.com>

CALCULATION NO. DL+LL-2L

PROJECT: Culvert Replacement - North Street over White Brook
LOCATION: Agawam, MA
CALCULATED BY: MJO **DATE:** 4/11/2023
CHECKED BY: MAR **DATE:** 4/11/2023

OBJECTIVE: Evaluate unfactored dead and live load (DL and LL, respectively) footing reactions of the North Street over White Brook proposed culvert replacement **at the approximate low point of settlement evaluation area No. C2.**

REFERENCE: See cover.

ASSUMPTIONS AND INPUT

GENERAL ASSUMPTIONS

- See assumptions on calculation package cover page.

Culvert Shape =	ALSP 18'0" Span x 7'-8" Rise		Reference #3 of cover page
Span (S) =	18	ft	Reference #3 of cover page
Total Lateral footing projection beyond culvert span (L _{FP}) =	0	ft	See cover page assumptions for foundation width
Arch Top Rise (Rt) =	7.7	ft	Reference #3 of cover page
Bottom Span =	18.0	ft	Reference #3 of cover page
Area of Top Rise (At) =	104.5	sq ft	Reference #3 of cover page
Footing contact angle (fca) =	8.94	degrees	Reference #3 of cover page
Total Height of Cover (Ht) =	18.5	ft	Reference #4
Height of Cover over Culvert (H) =	10.8	ft	See cover page assumptions
Axle Load Type =	Tandem (HL-93)	lbs	Reference #3 of cover page
Number of Lanes =	2		Reference #4
Axle Load (AL) =	100,000	lbs	Reference #3 of cover page
ES-LWA Soil Density (γ _{ES-LWA}) =	70	pcf	See cover page assumptions
Height of ES-LWA fill cover over Culvert (H _{ES-LWA}) =	1	ft	See cover page assumptions
UL-FGA Soil Density (γ _{UL-FGA}) =	25	pcf	See cover page assumptions
Height of UL-FGA fill cover over Culvert (H _{UL-FGA}) =	8.33	ft	See cover page assumptions
Topsoil Soil Density (γ _{NW}) =	125	pcf	See cover page assumptions
Height of Normal Weight fill cover over Culvert (H _{NW}) =	1.5	ft	See cover page assumptions

LOAD ON STRUCTURE

Live Load

$$\text{Live Load, LL} = \frac{AL}{(8 + 2(H + Rt))} / 1000$$

$$\text{Live Load} = \frac{2.2}{\text{kips / ft per footing}}$$

Dead Load

$$\text{Dead Load, DL} = \text{Weight of Soil overlying Culvert Footing}$$

Weighted area average for Soil Unit Weight

$$\text{Cross-sectional area of ES-LWA over Culvert (A}_{ES-LWA}) = \frac{(S + L_{FP}) \times (Rt + H_{ES-LWA}) - At}{\text{sq ft}}$$

$$\text{Cross-sectional area of ES-LWA over Culvert (A}_{ES-LWA}) = \frac{51.6}{\text{sq ft}}$$

$$\text{Cross-sectional area of UL-FGA over Culvert (A}_{UL-FGA}) = \frac{H_{UL-FGA} \times (S + L_{FP})}{\text{sq ft}}$$

$$\text{Cross-sectional area of UL-FGA over Culvert (A}_{UL-FGA}) = \frac{149.9}{\text{sq ft}}$$

$$\text{Cross-sectional area of NW fill over Culvert (A}_{NW}) = \frac{H_{NW} \times (S + L_{FP})}{\text{sq ft}}$$

$$\text{Cross-sectional area of NW fill over Culvert (A}_{NW}) = \frac{27}{\text{sq ft}}$$

Weighted Soil Unit Weight

$$\text{Weighted Soil Density (ES-LWA, UL-FGA and NW Fills)} = \frac{(\gamma_{UL-FGA} \times A_{UL-FGA} + \gamma_{ES-LWA} \times A_{ES-LWA} + \gamma_{NW} \times (A_{NW}))}{(A_{UL-FGA} + A_{ES-LWA} + A_{NW})}$$

$$\text{Weighted Soil Density (ES-LWA, UL-FGA and NW Fills)} = \frac{47.0}{\text{pcf}}$$

Soil Weight

$$\text{Soil Weight} = \frac{((S + L_{FP}) \times (H + Rt) - At) \times \text{Weighted Soil Density}}{1000 \text{ lb/kip}}$$

$$\text{Soil Weight} = \frac{10.7}{\text{kips / ft}}$$

$$\text{Dead Load} = \frac{5.4}{\text{kips / ft per footing}}$$

Total Load

$$\text{Total Load, V} = \text{Live Load} + \text{Dead Load}$$

$$\text{Total Load, V} = \frac{7.6}{\text{kips / ft per footing}}$$



GZA
GeoEnvironmental, Inc.
 249 Vanderbilt Ave
 Norwood, MA 02062
 781-278-3700
<http://www.gza.com>

CALCULATION NO. DL+LL-2L

PROJECT: Culvert Replacement - North Street over White Brook
LOCATION: Agawam, MA
CALCULATED BY: MJO **DATE:** 4/11/2023
CHECKED BY: MAR **DATE:** 4/11/2023

OBJECTIVE: Evaluate unfactored dead and live load (DL and LL, respectively) footing reactions of the North Street over White Brook proposed culvert replacement **at the approximate low point of settlement evaluation area No. C2.**

REFERENCE: See cover.

FOOTING REACTIONS

Vertical

$R_V =$	$V \times \cos(fca)$	
$R_{V,LL} =$	2.2	kips / ft per footing
$R_{V,DL} =$	5.3	kips / ft per footing
$R_V \text{ Total} =$	7.5	kips / ft per footing

Horizontal

$R_H =$	$V \times \sin(fca)$	
$R_{H,LL} =$	0.3	kips / ft per footing
$R_{H,DL} =$	0.8	kips / ft per footing
$R_H \text{ Total} =$	1.2	kips / ft per footing <u>outward</u>



GZA
GeoEnvironmental, Inc.
 249 Vanderbilt Ave
 Norwood, MA 02062
 781-278-3700
<http://www.gza.com>

CALCULATION NO. DL+LL-2H

PROJECT: Culvert Replacement - North Street over White Brook
 LOCATION: Agawam, MA
 CALCULATED BY: MJO DATE: 4/11/2023
 CHECKED BY: MAR DATE: 4/11/2023

OBJECTIVE: Evaluate unfactored dead and live load (DL and LL, respectively) footing reactions of the North Street over White Brook proposed culvert replacement at the approximate high point of settlement evaluation area No. C2.
REFERENCE: See cover.

ASSUMPTIONS AND INPUT

GENERAL ASSUMPTIONS

- See assumptions on calculation package cover page.

Culvert Shape =	ALSP 18'0" Span x 7'-8" Rise		Reference #3 of cover page
Span (S) =	18	ft	Reference #3 of cover page
Total Lateral footing projection beyond culvert span (L _{FP}) =	0	ft	See cover page assumptions for foundation width
Arch Top Rise (Rt) =	7.7	ft	Reference #3 of cover page
Bottom Span =	18.0	ft	Reference #3 of cover page
Area of Top Rise (At) =	104.5	sq ft	Reference #3 of cover page
Footing contact angle (fca) =	8.94	degrees	Reference #3 of cover page
Total Height of Cover (Ht) =	19.5	ft	Reference #4
Height of Cover over Culvert (H) =	11.8	ft	See cover page assumptions
Axle Load Type =	Tandem (HL-93)	lbs	Reference #3 of cover page
Number of Lanes =	2		Reference #4
Axle Load (AL) =	100,000	lbs	Reference #3 of cover page
ES-LWA Soil Density (γ _{ES-LWA}) =	70	pcf	See cover page assumptions
Height of ES-LWA fill cover over Culvert (H _{ES-LWA}) =	1	ft	See cover page assumptions
UL-FGA Soil Density (γ _{UL-FGA}) =	25	pcf	See cover page assumptions
Height of UL-FGA fill cover over Culvert (H _{UL-FGA}) =	9.33	ft	See cover page assumptions
Topsoil Soil Density (γ _{NW}) =	125	pcf	See cover page assumptions
Height of Normal Weight fill cover over Culvert (H _{NW}) =	1.5	ft	See cover page assumptions

LOAD ON STRUCTURE

Live Load

$$\text{Live Load, LL} = \frac{AL}{(8 + 2(H + Rt))} / 1000$$

$$\text{Live Load} = \frac{2.1}{\text{kips / ft per footing}}$$

Dead Load

$$\text{Dead Load, DL} = \text{Weight of Soil overlying Culvert Footing}$$

Weighted area average for Soil Unit Weight

$$\text{Cross-sectional area of ES-LWA over Culvert (A}_{ES-LWA}) = \frac{(S + L_{FP}) \times (Rt + H_{ES-LWA}) - At}{\text{sq ft}}$$

$$\text{Cross-sectional area of ES-LWA over Culvert (A}_{ES-LWA}) = \frac{51.6}{\text{sq ft}}$$

$$\text{Cross-sectional area of UL-FGA over Culvert (A}_{UL-FGA}) = \frac{H_{UL-FGA} \times (S + L_{FP})}{\text{sq ft}}$$

$$\text{Cross-sectional area of UL-FGA over Culvert (A}_{UL-FGA}) = \frac{167.9}{\text{sq ft}}$$

$$\text{Cross-sectional area of NW fill over Culvert (A}_{NW}) = \frac{H_{NW} \times (S + L_{FP})}{\text{sq ft}}$$

$$\text{Cross-sectional area of NW fill over Culvert (A}_{NW}) = \frac{27}{\text{sq ft}}$$

Weighted Soil Unit Weight

$$\text{Weighted Soil Density (ES-LWA, UL-FGA and NW Fills)} = \frac{(\gamma_{UL-FGA} \times A_{UL-FGA} + \gamma_{ES-LWA} \times A_{ES-LWA} + \gamma_{NW} \times (A_{NW}))}{(A_{UL-FGA} + A_{ES-LWA} + A_{NW})}$$

$$\text{Weighted Soil Density (ES-LWA, UL-FGA and NW Fills)} = \frac{45.4}{\text{pcf}}$$

Soil Weight

$$\text{Soil Weight} = \frac{((S + L_{FP}) \times (H + Rt) - At) \times \text{Weighted Soil Density}}{1000 \text{ lb/kip}}$$

$$\text{Soil Weight} = \frac{11.2}{\text{kips / ft}}$$

$$\text{Dead Load} = \frac{5.6}{\text{kips / ft per footing}}$$

Total Load

$$\text{Total Load, V} = \text{Live Load} + \text{Dead Load}$$

$$\text{Total Load, V} = \frac{7.7}{\text{kips / ft per footing}}$$



GZA
GeoEnvironmental, Inc.
249 Vanderbilt Ave
Norwood, MA 02062
781-278-3700
<http://www.gza.com>

CALCULATION NO. DL+LL-2H

PROJECT: Culvert Replacement - North Street over White Brook
LOCATION: Agawam, MA
CALCULATED BY: MJO **DATE:** 4/11/2023
CHECKED BY: MAR **DATE:** 4/11/2023

OBJECTIVE: Evaluate unfactored dead and live load (DL and LL, respectively) footing reactions of the North Street over White Brook proposed culvert replacement **at the approximate high point of settlement evaluation area No. C2.**
REFERENCE: See cover.

FOOTING REACTIONS

Vertical

$R_V =$	$V \times \cos(fca)$	
$R_{V,LL} =$	2.1	kips / ft per footing
$R_{V,DL} =$	5.5	kips / ft per footing
$R_V \text{ Total} =$	7.6	kips / ft per footing

Horizontal

$R_H =$	$V \times \sin(fca)$	
$R_{H,LL} =$	0.3	kips / ft per footing
$R_{H,DL} =$	0.9	kips / ft per footing
$R_H \text{ Total} =$	1.2	kips / ft per footing <u>outward</u>



GZA
GeoEnvironmental, Inc.
 249 Vanderbilt Ave
 Norwood, MA 02062
 781-278-3700
<http://www.gza.com>

CALCULATION NO. DL-3L

PROJECT: Culvert Replacement - North Street over White Brook
 LOCATION: Agawam, MA
 CALCULATED BY: MJO DATE: 4/11/2023
 CHECKED BY: MAR DATE: 4/11/2023

OBJECTIVE: Evaluate unfactored dead load (DL) footing reactions of the North Street over White Brook proposed culvert replacement at the approximate low point of settlement evaluation area No. C3.
REFERENCE: See cover.

ASSUMPTIONS AND INPUT

GENERAL ASSUMPTIONS

- See assumptions on calculation package cover page.

Culvert Shape =	ALSP 18'0" Span x 7'-8" Rise		Reference #3 of cover page
Span (S) =	18	ft	Reference #3 of cover page
Total Lateral footing projection beyond culvert span (L _{FP}) =	4	ft	See cover page assumptions for foundation width
Arch Top Rise (Rt) =	7.7	ft	Reference #3 of cover page
Bottom Span =	18.0	ft	Reference #3 of cover page
Area of Top Rise (At) =	104.5	sq ft	Reference #3 of cover page
Footing contact angle (fca) =	8.94	degrees	Reference #3 of cover page
Total Height of Cover (Ht) =	10.5	ft	Reference #4
Height of Cover over Culvert (H) =	2.8	ft	See cover page assumptions
Axle Load Type =	0	lbs	Reference #3 of cover page
Number of Lanes =	0		Reference #4
Axle Load (AL) =	0	lbs	Reference #3 of cover page
ES-LWA Soil Density (γ _{ES-LWA}) =	70	pcf	See cover page assumptions
Height of ES-LWA fill cover over Culvert (H _{ES-LWA}) =	1.5	ft	See cover page assumptions
UL-FGA Soil Density (γ _{UL-FGA}) =	25	pcf	See cover page assumptions
Height of UL-FGA fill cover over Culvert (H _{UL-FGA}) =	0.3	ft	See cover page assumptions
Topsoil Soil Density (γ _{NW}) =	118	pcf	See cover page assumptions, topsoil
Height of Normal Weight fill cover over Culvert (H _{NW}) =	1	ft	See cover page assumptions

LOAD ON STRUCTURE

Live Load

$$\text{Live Load, LL} = \frac{AL}{(8 + 2(H + Rt)) / 1000}$$

$$\text{Live Load} = \frac{0.0}{\text{}} \text{ kips / ft per footing}$$

Dead Load

$$\text{Dead Load, DL} = \text{Weight of Soil overlying Culvert Footing}$$

Weighted area average for Soil Unit Weight

$$\text{Cross-sectional area of ES-LWA over Culvert (A}_{ES-LWA}\text{)} = \frac{(S + L_{FP}) \times (Rt + H_{ES-LWA}) - A_t}{\text{}} \text{ sq ft}$$

$$\text{Cross-sectional area of ES-LWA over Culvert (A}_{ES-LWA}\text{)} = \frac{97.2}{\text{}} \text{ sq ft}$$

$$\text{Cross-sectional area of UL-FGA over Culvert (A}_{UL-FGA}\text{)} = \frac{H_{UL-FGA} \times (S + L_{FP})}{\text{}} \text{ sq ft}$$

$$\text{Cross-sectional area of UL-FGA over Culvert (A}_{UL-FGA}\text{)} = \frac{6.6}{\text{}} \text{ sq ft}$$

$$\text{Cross-sectional area of NW fill over Culvert (A}_{NW}\text{)} = \frac{H_{NW} \times (S + L_{FP})}{\text{}} \text{ sq ft}$$

$$\text{Cross-sectional area of NW fill over Culvert (A}_{NW}\text{)} = \frac{22}{\text{}} \text{ sq ft}$$

Weighted Soil Unit Weight

$$\text{Weighted Soil Density (ES-LWA, UL-FGA and NW Fills)} = \frac{\gamma_{UL-FGA} \times A_{UL-FGA} + \gamma_{ES-LWA} \times A_{ES-LWA} + \gamma_{NW} \times (A_{NW})}{(A_{UL-FGA} + A_{ES-LWA} + A_{NW})}$$

$$\text{Weighted Soil Density (ES-LWA, UL-FGA and NW Fills)} = \frac{76.0}{\text{}} \text{ pcf}$$

Soil Weight

$$\text{Soil Weight} = \frac{((S + L_{FP}) \times (H + Rt) - A_t) \times \text{Weighted Soil Density}}{1000 \text{ lb/kip}}$$

$$\text{Soil Weight} = \frac{9.6}{\text{}} \text{ kips / ft}$$

$$\text{Dead Load} = \frac{4.8}{\text{}} \text{ kips / ft per footing}$$

Total Load

$$\text{Total Load, V} = \text{Live Load} + \text{Dead Load}$$

$$\text{Total Load, V} = \frac{4.8}{\text{}} \text{ kips / ft per footing}$$



GZA
GeoEnvironmental, Inc.
 249 Vanderbilt Ave
 Norwood, MA 02062
 781-278-3700
<http://www.gza.com>

CALCULATION NO. DL-3L

PROJECT: Culvert Replacement - North Street over White Brook
 LOCATION: Agawam, MA
 CALCULATED BY: MJO DATE: 4/11/2023
 CHECKED BY: MAR DATE: 4/11/2023

OBJECTIVE:

Evaluate unfactored dead load (DL) footing reactions of the North Street over White Brook proposed culvert replacement **at the approximate low point of settlement evaluation area No. C3.**

REFERENCE:

See cover.

FOOTING REACTIONS

Vertical

$R_V =$	$V \times \cos(\text{fca})$	
$R_{V,LL} =$	<u>0.0</u>	kips / ft per footing
$R_{V,DL} =$	<u>4.8</u>	kips / ft per footing
$R_V \text{ Total} =$	<u>4.8</u>	kips / ft per footing

Horizontal

$R_H =$	$V \times \sin(\text{fca})$	
$R_{H,LL} =$	<u>0.0</u>	kips / ft per footing
$R_{H,DL} =$	<u>0.7</u>	kips / ft per footing
$R_H \text{ Total} =$	<u>0.7</u>	kips / ft per footing <u>outward</u>



GZA
GeoEnvironmental, Inc.
 249 Vanderbilt Ave
 Norwood, MA 02062
 781-278-3700
<http://www.gza.com>

CALCULATION NO. DL+LL-3H

PROJECT: Culvert Replacement - North Street over White Brook
 LOCATION: Agawam, MA
 CALCULATED BY: MJO DATE: 4/11/2023
 CHECKED BY: MAR DATE: 4/11/2023

OBJECTIVE: Evaluate unfactored dead and live load (DL and LL, respectively) footing reactions of the North Street over White Brook proposed culvert replacement **at the approximate high point of settlement evaluation area No. C3.**

REFERENCE: See cover.

ASSUMPTIONS AND INPUT

GENERAL ASSUMPTIONS

- See assumptions on calculation package cover page.

Culvert Shape =	ALSP 18'0" Span x 7'-8" Rise		Reference #3 of cover page
Span (S) =	18	ft	Reference #3 of cover page
Total Lateral footing projection beyond culvert span (L _{FP}) =	4	ft	See cover page assumptions for foundation width
Arch Top Rise (Rt) =	7.7	ft	Reference #3 of cover page
Bottom Span =	18.0	ft	Reference #3 of cover page
Area of Top Rise (At) =	104.5	sq ft	Reference #3 of cover page
Footing contact angle (fca) =	8.94	degrees	Reference #3 of cover page
Total Height of Cover (Ht) =	19.5	ft	Reference #4
Height of Cover over Culvert (H) =	11.8	ft	See cover page assumptions
Axle Load Type =	Tandem (HL-93)	lbs	Reference #3 of cover page
Number of Lanes =	1		Reference #4
Axle Load (AL) =	50,000	lbs	Reference #3 of cover page
ES-LWA Soil Density (γ_{ES-LWA}) =	70	pcf	See cover page assumptions
Height of ES-LWA fill cover over Culvert (H _{ES-LWA}) =	1.5	ft	See cover page assumptions
UL-FGA Soil Density (γ_{UL-FGA}) =	25	pcf	See cover page assumptions
Height of UL-FGA fill cover over Culvert (H _{UL-FGA}) =	9.33	ft	See cover page assumptions
Topsoil Soil Density (γ_{NW}) =	118	pcf	See cover page assumptions, topsoil
Height of Normal Weight fill cover over Culvert (H _{NW}) =	1	ft	See cover page assumptions

LOAD ON STRUCTURE

Live Load

$$\text{Live Load, LL} = \frac{AL}{(8 + 2(H + Rt)) / 1000}$$

$$\text{Live Load} = \frac{1.1}{\text{kips / ft per footing}}$$

Dead Load

$$\text{Dead Load, DL} = \frac{\text{Weight of Soil overlying Culvert Footing}}{\text{kips / ft per footing}}$$

Weighted area average for Soil Unit Weight

$$\text{Cross-sectional area of ES-LWA over Culvert (A}_{ES-LWA}) = \frac{(S + L_{FP}) \times (Rt + H_{ES-LWA}) - A_t}{\text{sq ft}}$$

$$\text{Cross-sectional area of ES-LWA over Culvert (A}_{ES-LWA}) = \frac{97.2}{\text{sq ft}}$$

$$\text{Cross-sectional area of UL-FGA over Culvert (A}_{UL-FGA}) = \frac{H_{UL-FGA} \times (S + L_{FP})}{\text{sq ft}}$$

$$\text{Cross-sectional area of UL-FGA over Culvert (A}_{UL-FGA}) = \frac{205.3}{\text{sq ft}}$$

$$\text{Cross-sectional area of NW fill over Culvert (A}_{NW}) = \frac{H_{NW} \times (S + L_{FP})}{\text{sq ft}}$$

$$\text{Cross-sectional area of NW fill over Culvert (A}_{NW}) = \frac{22}{\text{sq ft}}$$

Weighted Soil Unit Weight

$$\text{Weighted Soil Density (ES-LWA, UL-FGA and NW Fills)} = \frac{\gamma_{UL-FGA} \times A_{UL-FGA} + \gamma_{ES-LWA} \times A_{ES-LWA} + \gamma_{NW} \times (A_{NW})}{(A_{UL-FGA} + A_{ES-LWA} + A_{NW})}$$

$$\text{Weighted Soil Density (ES-LWA, UL-FGA and NW Fills)} = \frac{44.8}{\text{pcf}}$$

Soil Weight

$$\text{Soil Weight} = \frac{((S + L_{FP}) \times (H + Rt) - A_t) \times \text{Weighted Soil Density}}{1000 \text{ lb/kip}}$$

$$\text{Soil Weight} = \frac{14.5}{\text{kips / ft}}$$

$$\text{Dead Load} = \frac{7.3}{\text{kips / ft per footing}}$$

Total Load

$$\text{Total Load, V} = \frac{\text{Live Load} + \text{Dead Load}}{\text{kips / ft per footing}}$$

$$\text{Total Load, V} = \frac{8.3}{\text{kips / ft per footing}}$$



GZA
GeoEnvironmental, Inc.
 249 Vanderbilt Ave
 Norwood, MA 02062
 781-278-3700
<http://www.gza.com>

CALCULATION NO. DL+LL-3H

PROJECT: Culvert Replacement - North Street over White Brook
 LOCATION: Agawam, MA
 CALCULATED BY: MJO DATE: 4/11/2023
 CHECKED BY: MAR DATE: 4/11/2023

OBJECTIVE:

Evaluate unfactored dead and live load (DL and LL, respectively) footing reactions of the North Street over White Brook proposed culvert replacement **at the approximate high point of settlement evaluation area No. C3.**
 See cover.

REFERENCE:

FOOTING REACTIONS

Vertical

$R_V =$	<u> </u>	<u> </u>
	$V \times \cos(\text{fca})$	
$R_{V,LL} =$	<u> 1.1 </u>	kips / ft per footing
$R_{V,DL} =$	<u> 7.2 </u>	kips / ft per footing
$R_V \text{ Total} =$	<u> 8.2 </u>	kips / ft per footing

Horizontal

$R_H =$	<u> </u>	<u> </u>
	$V \times \sin(\text{fca})$	
$R_{H,LL} =$	<u> 0.2 </u>	kips / ft per footing
$R_{H,DL} =$	<u> 1.1 </u>	kips / ft per footing
$R_H \text{ Total} =$	<u> 1.3 </u>	kips / ft per footing <u>outward</u>

Structural Plate Footing Reactions

Per AASHTO Standard Specifications for Highway Bridges, Section 12



Project Name: _____

Merlin #: _____

Location: _____

Date: 2/15/2023

Tandem (HL93) Live Load

Corrugation =	ALSP	
Shape =	ALSP 18'-0" Span x 7'-8" Rise	
Span (S) =	18.00	ft.
Rise (R) =	7.67	ft.
Arch Top Rise (Rt) =	7.67	ft.
Bottom Span =	18.00	ft.
Area (A) =	104.5	sq. ft.
Area of Top Rise (At) =	104.5	sq. ft.
Footing contact angle (fca) =	8.94	degrees
Height of cover (H) =	10.00	ft.
Axle Load =	Tandem (HL93)	lbs.
Number of Lanes =	2	
Axle Load (AL) =	100,000	lbs.
Soil Density =	120	lbs./cu. ft.

GZA NOTE: INITIAL LOADING CALCULATED BY THE MANUFACTURER BUT DOES NOT INCLUDE WEIGHT OF SOIL OVERLYING PORTION OF FOOTING EXTENDING BEYOND THE SPAN ENDS OF THE CULVERT.

LOAD ON STRUCTURE

Total Load, V = Live Load + Dead Load

Live Load, LL =	$AL / (8 + 2(H + R))$	
Live Load =	2,307	lbs./foot/footing

MULTI-PLATE & Aluminum Structural Plate Single Radius Arch

Dead Load, DL =	Soil weight	
Soil weight =	$(S \times (H + Rt) - At) \times \text{Soil Density}$	
Soil weight =	25,627	lbs./foot
Dead Load per footing =	12,814	lbs./foot/footing

Dead Load =	12,814	lbs./foot/footing
Total Load, V =	15,121	lbs./foot/footing

FOOTING REACTIONS

Vertical

$R_V =$	$V \times \cos(fca)$	
$R_{V,LL} =$	2,279	
$R_{V,DL} =$	12,658	
$R_V \text{ Total} =$	14,937	lbs./foot/footing

Horizontal

$R_H =$	$V \times \sin(fca)$	
$R_{H,LL} =$	359	
$R_{H,DL} =$	1,992	
$R_H \text{ Total} =$	2,350	lbs./foot/footing <u>outward</u>

Use these Unfactored Reactions for preliminary footing design unless it is known that Factored Reactions are required.

These results are submitted to you as a guideline only, without liability on the part of Contech Engineered Solutions LLC for accuracy or suitability to any particular application, and are subject to your verification.

Comparison of Consolidation Pressures: Existing and Proposed Conditions - North Street over White Brook Proposed Culvert



Project:	Culvert Replacement - North Street over White Brook		
Location:	Agawam, MA		
Calculated By:	MJO	Date:	4/4/2023
Checked By:		Date:	

Purpose: Evaluate pre- and post-construction consolidation pressures for select foundation footprint areas of the proposed North Street over White Brook replacement culvert in general accordance with the MassDOT LRFD Bridge Design Manual, which references the AASHTO LRFD Bridge Design Specification, 9th Edition (2020). The proposed culvert is being analyzed as an AASHTO Bridge in accordance with MGL Chapter 85, Section 35 and is anticipated to be a single-span aluminum structural plate single radius arch structure with culvert/abutment ends supported on a shallow foundation bearing on existing natural fine-grained soils. The evaluation sections will be selected from three general culvert footprint areas: C1 - the upstream 1/3 where a raise-in-grade (RIG) is proposed, C2 - the middle 1/3 (generally no RIG proposed), and C3 - the downstream 1/3 where a RIG is proposed. Post-construction consolidation pressures less than or equal to pre-consolidation pressures will be used to evaluate recompression settlement while post-construction consolidation pressures greater than pre-consolidation pressures will be used to evaluate virgin settlement in a separate calculation.

- References:**
- 1) MassDOT Bridge Design Manual, 2013 with 2020 updates.
 - 2) AASHTO LRFD Bridge Design Specifications, 9th Edition, 2020.
 - 3) Subsurface conditions based on recent borings BB-01 through BB-03 completed from December 28 to 30, 2022, by Seaboard Drilling, Inc. of Springfield, Massachusetts, observed and logged by GZA. Subsurface conditions from the recent borings supplemented by subsurface conditions based on previous borings WB-1 and WB-2 completed on November 12, 2020, by Seaboard Drilling, Inc. of Springfield, Massachusetts, observed and logged by O'Rielly, Talbot & Okun.
 - 4) Email from Woodard & Curran (W&C) with calculations prepared by Contech Engineered Solutions LLC (Contech) for Structural Plate Footing Reactions per AASHTO Standard Specification for Highway Bridges, Section 12, dated February 15, 2023.
 - 5) Appendix G Attachments 1 and 3 - Preliminary Design Progress Print showing plan and section views of the proposed culvert prepared by Woodard & Curran (W&C), respectively, dated February 16, 2023 with PDF markups by GZA.

Subsurface Conditions: Estimated bottom of foundation base course grades at area Nos. C1, C2, and C3 are depicted as approximately 4 to 21 feet below the existing ground surface grades, which correspond to approximately 10 to 21 feet below proposed ground surface grades based on the longitudinal culvert profile view in Reference #5.

- Analysis Assumptions:**
- 1) Proposed culvert dimensions and location as depicted in Reference #5.
 - 2) Proposed culvert foundation assumed to be a 22-foot-wide continuous reinforced lightweight concrete mat foundation over a 1-foot-thick crushed stone base course as depicted in the mark ups in Reference #5.
 - 3) Pre-consolidation pressures assumed to consist only of existing soil, neglecting the effects of hydrostatic pore pressures.
 - 4) Post-construction consolidation pressures determined using the weight of the 1-foot of 3/4-inch crushed stone (CS) base course fill, a 1-foot-thick reinforced lightweight concrete mat foundation, 2-feet of streambed (SB) fill material, and the following fill materials over the proposed culvert and culvert foundation: Compacted expanded shale lightweight aggregate (ES-LWA) fill to between approximately 1- to 1.5-feet above the proposed culvert, compacted ultra-lightweight foamed glass aggregate (UL-FGA) fill on top of the ES-LWA to between 1- and 1.5-feet from proposed ground surface level and 1 to 1.5 feet of compacted normal-weight (NW) fill for the topsoil and roadway granular fill/asphalt to the proposed ground surface level. The pressures neglect the effects of hydrostatic pore pressures.

Results: The following table summarizes the pre-consolidation and post-construction consolidation pressures at the bottom of the proposed foundation base course grades for select areas of the proposed culvert at North Street over White Brook:

Culvert Settlement Evaluation Area ID - Description	Preconsolidation Pressure: Existing Condition (psf)	Consolidation Pressure: Post Construction (psf)	Comparison of Consolidation Pressures	
			Pre- minus Post- Construction (psf)	Notes
C1A - Upstream End	600	779	-179	net increased pressure
C1B - Upstream	1090	836	254	net decreased pressure
C1C - Upstream	814	814	0	-
C2A - Mid-length	2520	1061	1459	net decreased pressure
C3A - Downstream	1296	957	339	net decreased pressure
C3B - Downstream End	420	842	-422	net increased pressure
C3C - Downstream	947	947	0	-

Attachments: Calculations by GZA, Preliminary Design Drawings of proposed culvert with GZA markups (Attachments 1 and 3 of Appendix G)



GZA
GeoEnvironmental, Inc.
 249 Vanderbilt Ave
 Norwood, MA 02062
 781-278-3700
<http://www.gza.com>

CALCULATION: AREA C1A

PROJECT: Culvert Replacement - North Street over White Brook
 LOCATION: Agawam, MA
 CALCULATED BY: MJO DATE: 4/4/2023
 CHECKED BY: 0 DATE: 1/0/1900

OBJECTIVE: Evaluate the existing preconsolidation and proposed consolidation pressures for proposed foundation section area C1A of the North Street over White Brook proposed culvert replacement.
REFERENCE: See cover.

ASSUMPTIONS AND INPUT

GENERAL ASSUMPTIONS

- See assumptions on calculation package cover page.

Existing/Pre-Construction Conditions at Proposed Culvert Area

Approx. existing ground surface elevation/EI. (El _{EX}) =	122	ft	Reference #5 of cover page
Existing Soil estimated unit weight (γ _{EX}) =	120	ft	Reference #3 of cover page

Proposed Culvert Dimensions

Culvert Shape =	ALSP 18'0" Span x 7'-8" Rise		Reference #5 of cover page
Culvert Span (S) =	18	ft	Reference #5 of cover page
Total Lateral footing projection beyond culvert span (L _{FP}) =	4	ft	See cover page
Rise (R) =	7.7	ft	Reference #5 of cover page
Area (A) =	104.5	sq ft	Reference #5 of cover page

Proposed Materials

Approx. proposed ground surface elevation/EI. (El _{PR}) =	129	ft	Reference #5 of cover page
Proposed EI. for bottom of crushed stone for foundation (El _{BCS}) =	117	ft	Reference #5 of cover page
Unit Weight: NW fill (γ _{NW}) =	118	pcf	See cover page, topsoil
Unit Weight: ES-LWA fill (γ _{ES-LWA}) =	70	pcf	-
Unit Weight: UL-FGA fill (γ _{UL-FGA}) =	25	pcf	-
Unit Weight: Streambed Material (γ _{SB}) =	100	pcf	-
Unit Weight: Reinforced Lightweight Concrete (γ _{LWC}) =	100	pcf	-
Unit Weight: 3/4-inch Crushed Stone (γ _{CS}) =	115	pcf	-
Thickness: NW fill (t _{NW}) =	1	ft	See cover page
Thickness: ES-LWA fill (t _{ES-LWA}) =	8.7	ft	See cover page
Thickness: UL-FGA fill (t _{UL-FGA}) =	0.3	ft	See cover page
Thickness: Streambed Material (t _{SB}) =	2	ft	See cover page
Thickness: Reinforced Lightweight Concrete (t _{LWC}) =	1	ft	See cover page
Thickness: 3/4-inch Crushed Stone (t _{CS}) =	1	ft	See cover page

CALCULATION: EXISTING/PRE-CONSTRUCTION PRE-CONSOLIDATION PRESSURE

Existing Soil thickness (t _{EX}) =	El _{EX} - El _{BCS}	ft
Existing Soil thickness (t _{EX}) =	5	ft
Cross-sectional area of NW fill over Culvert El _{BCS} (A _{NW}) =	t _{EX} × (S + L _{FP})	
Cross-sectional area of NW fill over Culvert El _{BCS} (A _{NW}) =	110	sq ft
Existing Pre-Consolidation Pressure (P _{EX}) =	γ _{EX} × A _{NW} / (S + L _{FP})	
Existing Pre-Consolidation Pressure (P _{EX}) =	600	psf

CALCULATION: PROPOSED/POST-CONSTRUCTION CONSOLIDATION PRESSURE

Cross-sectional area of ES-LWA over Culvert foundation (A _{ES-LWA}) =	(S + L _{FP}) × (t _{ES-LWA}) - A	
Cross-sectional area of ES-LWA over Culvert foundation (A _{ES-LWA}) =	86.2	sq ft
Cross-sectional area of UL-FGA over Culvert foundation (A _{UL-FGA}) =	t _{UL-FGA} × (S + L _{FP})	
Cross-sectional area of UL-FGA over Culvert foundation (A _{UL-FGA}) =	7.3	sq ft
Cross-sectional area of NW fill over Culvert foundation (A _{NW}) =	t _{NW} × (S + L _{FP})	
Cross-sectional area of NW fill over Culvert foundation (A _{NW}) =	22	sq ft
Total Cross-sectional area: All Proposed fills (A _{PR}) =	A _{ES-LWA} + A _{UL-FGA} + A _{NW}	
Total Cross-sectional area: All Proposed fills (A _{PR}) =	115.5	sq ft
Cross-sectional area: Streambed Material (A _{SB}) =	t _{SB} × S	
Cross-sectional area: Streambed Material (A _{SB}) =	36.0	sq ft

Weighted Soil Unit Weight

Weighted Soil Density (ES-LWA, UL-FGA and NW Fills, γ _{PR}) =	(γ _{UL-FGA} × A _{UL-FGA} + γ _{ES-LWA} × A _{ES-LWA} + γ _{NW} × A _{NW}) / (A _{UL-FGA} + A _{ES-LWA} + A _{NW})	
Weighted Soil Density (ES-LWA, UL-FGA and NW Fills, γ _{PR}) =	76.3	pcf

Post-Construction Consolidation Pressure

Proposed / Post-Consolidation Pressure (P _{PR}) =	(γ _{PR} × A _{PR} + γ _{SB} × A _{SB}) / (S + L _{FP}) + γ _{LWC} × t _{LWC} + γ _{CS} × t _{CS}	
Proposed / Post-Consolidation Pressure (P _{PR}) =	779	psf



GZA
GeoEnvironmental, Inc.
 249 Vanderbilt Ave
 Norwood, MA 02062
 781-278-3700
<http://www.gza.com>

CALCULATION: AREA C1B

PROJECT: Culvert Replacement - North Street over White Brook
 LOCATION: Agawam, MA
 CALCULATED BY: MJO DATE: 4/4/2023
 CHECKED BY: 0 DATE: 1/0/1900

OBJECTIVE: Evaluate the existing preconsolidation and proposed consolidation pressures for proposed foundation section area C1B of the North Street over White Brook proposed culvert replacement.
REFERENCE: See cover.

ASSUMPTIONS AND INPUT

GENERAL ASSUMPTIONS

- See assumptions on calculation package cover page.

Existing/Pre-Construction Conditions at Proposed Culvert Area

Approx. existing ground surface elevation/EI. (El _{EX}) =	125.5	ft	Reference #5 of cover page
Existing Soil estimated unit weight (γ _{EX}) =	120	ft	Reference #3 of cover page

Proposed Culvert Dimensions

Culvert Shape =	ALSP 18'0" Span x 7'-8" Rise		Reference #5 of cover page
Culvert Span (S) =	18	ft	Reference #5 of cover page
Total Lateral footing projection beyond culvert span (L _{FP}) =	4	ft	See cover page
Rise (R) =	7.7	ft	Reference #5 of cover page
Area (A) =	104.5	sq ft	Reference #5 of cover page

Proposed Materials

Approx. proposed ground surface elevation/EI. (El _{PR}) =	130.7	ft	Reference #5 of cover page
Proposed EI. for bottom of crushed stone for foundation (El _{BCS}) =	116.4	ft	Reference #5 of cover page
Unit Weight: NW fill (γ _{NW}) =	118	pcf	See cover page, topsoil
Unit Weight: ES-LWA fill (γ _{ES-LWA}) =	70	pcf	-
Unit Weight: UL-FGA fill (γ _{UL-FGA}) =	25	pcf	-
Unit Weight: Streambed Material (γ _{SB}) =	100	pcf	-
Unit Weight: Reinforced Lightweight Concrete (γ _{LWC}) =	100	pcf	-
Unit Weight: 3/4-inch Crushed Stone (γ _{CS}) =	115	pcf	-
Thickness: NW fill (t _{NW}) =	1	ft	See cover page
Thickness: ES-LWA fill (t _{ES-LWA}) =	8.7	ft	See cover page
Thickness: UL-FGA fill (t _{UL-FGA}) =	2.6	ft	See cover page
Thickness: Streambed Material (t _{SB}) =	2	ft	See cover page
Thickness: Reinforced Lightweight Concrete (t _{LWC}) =	1	ft	See cover page
Thickness: 3/4-inch Crushed Stone (t _{CS}) =	1	ft	See cover page

CALCULATION: EXISTING/PRE-CONSTRUCTION PRE-CONSOLIDATION PRESSURE

Existing Soil thickness (t _{EX}) =	El _{EX} - El _{BCS}	ft
Existing Soil thickness (t _{EX}) =	9.08	ft
Cross-sectional area of NW fill over Culvert El _{BCS} (A _{NW}) =	t _{EX} x (S + L _{FP})	
Cross-sectional area of NW fill over Culvert El _{BCS} (A _{NW}) =	199.76	sq ft
Existing Pre-Consolidation Pressure (P _{EX}) =	γ _{EX} x A _{NW} / (S + L _{FP})	
Existing Pre-Consolidation Pressure (P _{EX}) =	1089.6	psf

CALCULATION: PROPOSED/POST-CONSTRUCTION CONSOLIDATION PRESSURE

Cross-sectional area of ES-LWA over Culvert foundation (A _{ES-LWA}) =	(S + L _{FP}) x (t _{ES-LWA}) - A	
Cross-sectional area of ES-LWA over Culvert foundation (A _{ES-LWA}) =	86.2	sq ft
Cross-sectional area of UL-FGA over Culvert foundation (A _{UL-FGA}) =	t _{UL-FGA} x (S + L _{FP})	
Cross-sectional area of UL-FGA over Culvert foundation (A _{UL-FGA}) =	56.8	sq ft
Cross-sectional area of NW fill over Culvert foundation (A _{NW}) =	t _{NW} x (S + L _{FP})	
Cross-sectional area of NW fill over Culvert foundation (A _{NW}) =	22	sq ft
Total Cross-sectional area: All Proposed fills (A _{PR}) =	A _{ES-LWA} + A _{UL-FGA} + A _{NW}	
Total Cross-sectional area: All Proposed fills (A _{PR}) =	165.0	sq ft
Cross-sectional area: Streambed Material (A _{SB}) =	t _{SB} x S	
Cross-sectional area: Streambed Material (A _{SB}) =	36.0	sq ft

Weighted Soil Unit Weight

Weighted Soil Density (ES-LWA, UL-FGA and NW Fills, γ _{PR}) =	(γ _{UL-FGA} x A _{UL-FGA} + γ _{ES-LWA} x A _{ES-LWA} + γ _{NW} x A _{NW}) / (A _{UL-FGA} + A _{ES-LWA} + A _{NW})	
Weighted Soil Density (ES-LWA, UL-FGA and NW Fills, γ _{PR}) =	60.9	pcf

Post-Construction Consolidation Pressure

Proposed / Post-Consolidation Pressure (P _{PR}) =	(γ _{PR} x A _{PR} + γ _{SB} x A _{SB}) / (S + L _{FP}) + γ _{LWC} x t _{LWC} + γ _{CS} x t _{CS}	
Proposed / Post-Consolidation Pressure (P _{PR}) =	836	psf



GZA
GeoEnvironmental, Inc.
 249 Vanderbilt Ave
 Norwood, MA 02062
 781-278-3700
<http://www.gza.com>

CALCULATION: AREA C1C

PROJECT: Culvert Replacement - North Street over White Brook
 LOCATION: Agawam, MA
 CALCULATED BY: MJO DATE: 4/4/2023
 CHECKED BY: 0 DATE: 1/0/1900

OBJECTIVE: Evaluate the existing preconsolidation and proposed consolidation pressures for proposed foundation section area C1C of the North Street over White Brook proposed culvert replacement.
REFERENCE: See cover.

ASSUMPTIONS AND INPUT

GENERAL ASSUMPTIONS

- See assumptions on calculation package cover page.

Existing/Pre-Construction Conditions at Proposed Culvert Area

Approx. existing ground surface elevation/EI. (E_{EX}) =	123.6	ft	Reference #5 of cover page
Existing Soil estimated unit weight (γ_{EX}) =	120	ft	Reference #3 of cover page

Proposed Culvert Dimensions

Culvert Shape =	ALSP 18'0" Span x 7'-8" Rise		Reference #5 of cover page
Culvert Span (S) =	18	ft	Reference #5 of cover page
Total Lateral footing projection beyond culvert span (L_{FP}) =	4	ft	See cover page
Rise (R) =	7.7	ft	Reference #5 of cover page
Area (A) =	104.5	sq ft	Reference #5 of cover page

Proposed Materials

Approx. proposed ground surface elevation/EI. (E_{PR}) =	130.2	ft	Reference #5 of cover page
Proposed EI. for bottom of crushed stone for foundation (E_{BCS}) =	116.8	ft	Reference #5 of cover page
Unit Weight: NW fill (γ_{NW}) =	118	pcf	See cover page, topsoil
Unit Weight: ES-LWA fill (γ_{ES-LWA}) =	70	pcf	-
Unit Weight: UL-FGA fill (γ_{UL-FGA}) =	25	pcf	-
Unit Weight: Streambed Material (γ_{SB}) =	100	pcf	-
Unit Weight: Reinforced Lightweight Concrete (γ_{LWC}) =	100	pcf	-
Unit Weight: 3/4-inch Crushed Stone (γ_{CS}) =	115	pcf	-
Thickness: NW fill (t_{NW}) =	1	ft	See cover page
Thickness: ES-LWA fill (t_{ES-LWA}) =	8.7	ft	See cover page
Thickness: UL-FGA fill (t_{UL-FGA}) =	1.7	ft	See cover page
Thickness: Streambed Material (t_{SB}) =	2	ft	See cover page
Thickness: Reinforced Lightweight Concrete (t_{LWC}) =	1	ft	See cover page
Thickness: 3/4-inch Crushed Stone (t_{CS}) =	1	ft	See cover page

CALCULATION: EXISTING/PRE-CONSTRUCTION PRE-CONSOLIDATION PRESSURE

Existing Soil thickness (t_{EX}) =	$E_{EX} - E_{BCS}$	ft
Existing Soil thickness (t_{EX}) =	6.8	ft
Cross-sectional area of NW fill over Culvert E_{BCS} (A_{NW}) =	$t_{EX} \times (S + L_{FP})$	
Cross-sectional area of NW fill over Culvert E_{BCS} (A_{NW}) =	149.3	sq ft
Existing Pre-Consolidation Pressure (P_{EX}) =	$\gamma_{EX} \times A_{NW} / (S + L_{FP})$	
Existing Pre-Consolidation Pressure (P_{EX}) =	814	psf

CALCULATION: PROPOSED/POST-CONSTRUCTION CONSOLIDATION PRESSURE

Cross-sectional area of ES-LWA over Culvert foundation (A_{ES-LWA}) =	$(S + L_{FP}) \times (t_{ES-LWA}) - A$	
Cross-sectional area of ES-LWA over Culvert foundation (A_{ES-LWA}) =	86.2	sq ft
Cross-sectional area of UL-FGA over Culvert foundation (A_{UL-FGA}) =	$t_{UL-FGA} \times (S + L_{FP})$	
Cross-sectional area of UL-FGA over Culvert foundation (A_{UL-FGA}) =	37.9	sq ft
Cross-sectional area of NW fill over Culvert foundation (A_{NW}) =	$t_{NW} \times (S + L_{FP})$	
Cross-sectional area of NW fill over Culvert foundation (A_{NW}) =	22	sq ft
Total Cross-sectional area: All Proposed fills (A_{PR}) =	$A_{ES-LWA} + A_{UL-FGA} + A_{NW}$	
Total Cross-sectional area: All Proposed fills (A_{PR}) =	146.1	sq ft
Cross-sectional area: Streambed Material (A_{SB}) =	$t_{SB} \times S$	
Cross-sectional area: Streambed Material (A_{SB}) =	36.0	sq ft

Weighted Soil Unit Weight

Weighted Soil Density (ES-LWA, UL-FGA and NW Fills, γ_{PR}) =	$(\gamma_{UL-FGA} \times A_{UL-FGA} + \gamma_{ES-LWA} \times A_{ES-LWA} + \gamma_{NW} \times A_{NW}) / (A_{UL-FGA} + A_{ES-LWA} + A_{NW})$	
Weighted Soil Density (ES-LWA, UL-FGA and NW Fills, γ_{PR}) =	65.6	pcf

Post-Construction Consolidation Pressure

Proposed / Post-Consolidation Pressure (P_{PR}) =	$(\gamma_{PR} \times A_{PR} + \gamma_{SB} \times A_{SB}) / (S + L_{FP}) + \gamma_{LWC} \times t_{LWC} + \gamma_{CS} \times t_{CS}$	
Proposed / Post-Consolidation Pressure (P_{PR}) =	814	psf



GZA
GeoEnvironmental, Inc.
 249 Vanderbilt Ave
 Norwood, MA 02062
 781-278-3700
<http://www.gza.com>

CALCULATION: AREA C2A

PROJECT: Culvert Replacement - North Street over White Brook
 LOCATION: Agawam, MA
 CALCULATED BY: MJO DATE: 4/4/2023
 CHECKED BY: 0 DATE: 1/0/1900

OBJECTIVE: Evaluate the existing preconsolidation and proposed consolidation pressures for proposed foundation section area C2A of the North Street over White Brook proposed culvert replacement.
REFERENCE: See cover.

ASSUMPTIONS AND INPUT

GENERAL ASSUMPTIONS

- See assumptions on calculation package cover page.

Existing/Pre-Construction Conditions at Proposed Culvert Area

Approx. existing ground surface elevation/EI. (E _{EX}) =	135.2	ft	Reference #5 of cover page
Existing Soil estimated unit weight (γ _{EX}) =	120	ft	Reference #3 of cover page

Proposed Culvert Dimensions

Culvert Shape =	ALSP 18'0" Span x 7'-8" Rise		Reference #5 of cover page
Culvert Span (S) =	18	ft	Reference #5 of cover page
Total Lateral footing projection beyond culvert span (L _{FP}) =	4	ft	See cover page
Rise (R) =	7.7	ft	Reference #5 of cover page
Area (A) =	104.5	sq ft	Reference #5 of cover page

Proposed Materials

Approx. proposed ground surface elevation/EI. (E _{PR}) =	135.2	ft	Reference #5 of cover page
Proposed EI. for bottom of crushed stone for foundation (E _{BCS}) =	114.2	ft	Reference #5 of cover page
Unit Weight: NW fill (γ _{NW}) =	125	pcf	See cover page, granular fill and asphalt
Unit Weight: ES-LWA fill (γ _{ES-LWA}) =	70	pcf	-
Unit Weight: UL-FGA fill (γ _{UL-FGA}) =	25	pcf	-
Unit Weight: Streambed Material (γ _{SB}) =	100	pcf	-
Unit Weight: Reinforced Lightweight Concrete (γ _{LWC}) =	100	pcf	-
Unit Weight: 3/4-inch Crushed Stone (γ _{CS}) =	115	pcf	-
Thickness: NW fill (t _{NW}) =	1.5	ft	See cover page
Thickness: ES-LWA fill (t _{ES-LWA}) =	8.7	ft	See cover page
Thickness: UL-FGA fill (t _{UL-FGA}) =	8.8	ft	See cover page
Thickness: Streambed Material (t _{SB}) =	2	ft	See cover page
Thickness: Reinforced Lightweight Concrete (t _{LWC}) =	1	ft	See cover page
Thickness: 3/4-inch Crushed Stone (t _{CS}) =	1	ft	See cover page

CALCULATION: EXISTING/PRE-CONSTRUCTION PRE-CONSOLIDATION PRESSURE

Existing Soil thickness (t _{EX}) =	E _{EX} - E _{BCS}	ft
Existing Soil thickness (t _{EX}) =	21	ft
Cross-sectional area of NW fill over Culvert E _{BCS} (A _{NW}) =	t _{EX} × (S + L _{FP})	
Cross-sectional area of NW fill over Culvert E _{BCS} (A _{NW}) =	462	sq ft
Existing Pre-Consolidation Pressure (P _{EX}) =	γ _{EX} × A _{NW} / (S + L _{FP})	
Existing Pre-Consolidation Pressure (P _{EX}) =	2520	psf

CALCULATION: PROPOSED/POST-CONSTRUCTION CONSOLIDATION PRESSURE

Cross-sectional area of ES-LWA over Culvert foundation (A _{ES-LWA}) =	(S + L _{FP}) × (t _{ES-LWA}) - A	
Cross-sectional area of ES-LWA over Culvert foundation (A _{ES-LWA}) =	86.2	sq ft
Cross-sectional area of UL-FGA over Culvert foundation (A _{UL-FGA}) =	t _{UL-FGA} × (S + L _{FP})	
Cross-sectional area of UL-FGA over Culvert foundation (A _{UL-FGA}) =	194.3	sq ft
Cross-sectional area of NW fill over Culvert foundation (A _{NW}) =	t _{NW} × (S + L _{FP})	
Cross-sectional area of NW fill over Culvert foundation (A _{NW}) =	33	sq ft
Total Cross-sectional area: All Proposed fills (A _{PR}) =	A _{ES-LWA} + A _{UL-FGA} + A _{NW}	
Total Cross-sectional area: All Proposed fills (A _{PR}) =	313.5	sq ft
Cross-sectional area: Streambed Material (A _{SB}) =	t _{SB} × S	
Cross-sectional area: Streambed Material (A _{SB}) =	36.0	sq ft

Weighted Soil Unit Weight

Weighted Soil Density (ES-LWA, UL-FGA and NW Fills, γ _{PR}) =	(γ _{UL-FGA} × A _{UL-FGA} + γ _{ES-LWA} × A _{ES-LWA} + γ _{NW} × A _{NW}) / (A _{UL-FGA} + A _{ES-LWA} + A _{NW})	
Weighted Soil Density (ES-LWA, UL-FGA and NW Fills, γ _{PR}) =	47.9	pcf

Post-Construction Consolidation Pressure

Proposed / Post-Consolidation Pressure (P _{PR}) =	(γ _{PR} × A _{PR} + γ _{SB} × A _{SB}) / (S + L _{FP}) + γ _{LWC} × t _{LWC} + γ _{CS} × t _{CS}	
Proposed / Post-Consolidation Pressure (P _{PR}) =	1061	psf



GZA
GeoEnvironmental, Inc.
 249 Vanderbilt Ave
 Norwood, MA 02062
 781-278-3700
<http://www.gza.com>

CALCULATION: AREA C3A

PROJECT: Culvert Replacement - North Street over White Brook
 LOCATION: Agawam, MA
 CALCULATED BY: MJO DATE: 4/4/2023
 CHECKED BY: 0 DATE: 1/0/1900

OBJECTIVE: Evaluate the existing preconsolidation and proposed consolidation pressures for proposed foundation section area C3A of the North Street over White Brook proposed culvert replacement.
REFERENCE: See cover.

ASSUMPTIONS AND INPUT

GENERAL ASSUMPTIONS

- See assumptions on calculation package cover page.

Existing/Pre-Construction Conditions at Proposed Culvert Area

Approx. existing ground surface elevation/EI. (El _{EX}) =	123	ft	Reference #5 of cover page
Existing Soil estimated unit weight (γ _{EX}) =	120	ft	Reference #3 of cover page

Proposed Culvert Dimensions

Culvert Shape =	ALSP 18'0" Span x 7'-8" Rise		Reference #5 of cover page
Culvert Span (S) =	18	ft	Reference #5 of cover page
Total Lateral footing projection beyond culvert span (L _{FP}) =	4	ft	See cover page
Rise (R) =	7.7	ft	Reference #5 of cover page
Area (A) =	104.5	sq ft	Reference #5 of cover page

Proposed Materials

Approx. proposed ground surface elevation/EI. (El _{PR}) =	131.3	ft	Reference #5 of cover page
Proposed EI. for bottom of crushed stone for foundation (El _{BCS}) =	112.2	ft	Reference #5 of cover page
Unit Weight: NW fill (γ _{NW}) =	118	pcf	See cover page, topsoil
Unit Weight: ES-LWA fill (γ _{ES-LWA}) =	70	pcf	-
Unit Weight: UL-FGA fill (γ _{UL-FGA}) =	25	pcf	-
Unit Weight: Streambed Material (γ _{SB}) =	100	pcf	-
Unit Weight: Reinforced Lightweight Concrete (γ _{LWC}) =	100	pcf	-
Unit Weight: 3/4-inch Crushed Stone (γ _{CS}) =	115	pcf	-
Thickness: NW fill (t _{NW}) =	1	ft	See cover page
Thickness: ES-LWA fill (t _{ES-LWA}) =	8.7	ft	See cover page
Thickness: UL-FGA fill (t _{UL-FGA}) =	7.4	ft	See cover page
Thickness: Streambed Material (t _{SB}) =	2	ft	See cover page
Thickness: Reinforced Lightweight Concrete (t _{LWC}) =	1	ft	See cover page
Thickness: 3/4-inch Crushed Stone (t _{CS}) =	1	ft	See cover page

CALCULATION: EXISTING/PRE-CONSTRUCTION PRE-CONSOLIDATION PRESSURE

Existing Soil thickness (t _{EX}) =	El _{EX} - El _{BCS}	ft
Existing Soil thickness (t _{EX}) =	10.8	ft
Cross-sectional area of NW fill over Culvert El _{BCS} (A _{NW}) =	t _{EX} x (S + L _{FP})	
Cross-sectional area of NW fill over Culvert El _{BCS} (A _{NW}) =	237.6	sq ft
Existing Pre-Consolidation Pressure (P _{EX}) =	γ _{EX} x A _{NW} / (S + L _{FP})	
Existing Pre-Consolidation Pressure (P _{EX}) =	1296	psf

CALCULATION: PROPOSED/POST-CONSTRUCTION CONSOLIDATION PRESSURE

Cross-sectional area of ES-LWA over Culvert foundation (A _{ES-LWA}) =	(S + L _{FP}) x (t _{ES-LWA}) - A	
Cross-sectional area of ES-LWA over Culvert foundation (A _{ES-LWA}) =	86.2	sq ft
Cross-sectional area of UL-FGA over Culvert foundation (A _{UL-FGA}) =	t _{UL-FGA} x (S + L _{FP})	
Cross-sectional area of UL-FGA over Culvert foundation (A _{UL-FGA}) =	163.5	sq ft
Cross-sectional area of NW fill over Culvert foundation (A _{NW}) =	t _{NW} x (S + L _{FP})	
Cross-sectional area of NW fill over Culvert foundation (A _{NW}) =	22	sq ft
Total Cross-sectional area: All Proposed fills (A _{PR}) =	A _{ES-LWA} + A _{UL-FGA} + A _{NW}	
Total Cross-sectional area: All Proposed fills (A _{PR}) =	271.7	sq ft
Cross-sectional area: Streambed Material (A _{SB}) =	t _{SB} x S	
Cross-sectional area: Streambed Material (A _{SB}) =	36.0	sq ft

Weighted Soil Unit Weight

Weighted Soil Density (ES-LWA, UL-FGA and NW Fills, γ _{PR}) =	(γ _{UL-FGA} x A _{UL-FGA} + γ _{ES-LWA} x A _{ES-LWA} + γ _{NW} x A _{NW}) / (A _{UL-FGA} + A _{ES-LWA} + A _{NW})	
Weighted Soil Density (ES-LWA, UL-FGA and NW Fills, γ _{PR}) =	46.8	pcf

Post-Construction Consolidation Pressure

Proposed / Post-Consolidation Pressure (P _{PR}) =	(γ _{PR} x A _{PR} + γ _{SB} x A _{SB}) / (S + L _{FP}) + γ _{LWC} x t _{LWC} + γ _{CS} x t _{CS}	
Proposed / Post-Consolidation Pressure (P _{PR}) =	957	psf



GZA
GeoEnvironmental, Inc.
 249 Vanderbilt Ave
 Norwood, MA 02062
 781-278-3700
<http://www.gza.com>

CALCULATION: AREA C3B

PROJECT: Culvert Replacement - North Street over White Brook
 LOCATION: Agawam, MA
 CALCULATED BY: MJO DATE: 4/4/2023
 CHECKED BY: 0 DATE: 1/0/1900

OBJECTIVE: Evaluate the existing preconsolidation and proposed consolidation pressures for proposed foundation section area C3B of the North Street over White Brook proposed culvert replacement.
REFERENCE: See cover.

ASSUMPTIONS AND INPUT

GENERAL ASSUMPTIONS

- See assumptions on calculation package cover page.

Existing/Pre-Construction Conditions at Proposed Culvert Area

Approx. existing ground surface elevation/EI. (El _{EX}) =	115	ft	Reference #5 of cover page
Existing Soil estimated unit weight (γ _{EX}) =	120	ft	Reference #3 of cover page

Proposed Culvert Dimensions

Culvert Shape =	ALSP 18'0" Span x 7'-8" Rise		Reference #5 of cover page
Culvert Span (S) =	18	ft	Reference #5 of cover page
Total Lateral footing projection beyond culvert span (L _{FP}) =	4	ft	See cover page
Rise (R) =	7.7	ft	Reference #5 of cover page
Area (A) =	104.5	sq ft	Reference #5 of cover page

Proposed Materials

Approx. proposed ground surface elevation/EI. (El _{PR}) =	124	ft	Reference #5 of cover page
Proposed EI. for bottom of crushed stone for foundation (El _{BCS}) =	111.5	ft	Reference #5 of cover page
Unit Weight: NW fill (γ _{NW}) =	118	pcf	See cover page, topsoil
Unit Weight: ES-LWA fill (γ _{ES-LWA}) =	70	pcf	-
Unit Weight: UL-FGA fill (γ _{UL-FGA}) =	25	pcf	-
Unit Weight: Streambed Material (γ _{SB}) =	100	pcf	-
Unit Weight: Reinforced Lightweight Concrete (γ _{LWC}) =	100	pcf	-
Unit Weight: 3/4-inch Crushed Stone (γ _{CS}) =	115	pcf	-
Thickness: NW fill (t _{NW}) =	1.3	ft	See cover page
Thickness: ES-LWA fill (t _{ES-LWA}) =	9.2	ft	See cover page
Thickness: UL-FGA fill (t _{UL-FGA}) =	0.0	ft	See cover page
Thickness: Streambed Material (t _{SB}) =	2	ft	See cover page
Thickness: Reinforced Lightweight Concrete (t _{LWC}) =	1	ft	See cover page
Thickness: 3/4-inch Crushed Stone (t _{CS}) =	1	ft	See cover page

CALCULATION: EXISTING/PRE-CONSTRUCTION PRE-CONSOLIDATION PRESSURE

Existing Soil thickness (t _{EX}) =	El _{EX} - El _{BCS}	ft
Existing Soil thickness (t _{EX}) =	3.5	ft
Cross-sectional area of NW fill over Culvert El _{BCS} (A _{NW}) =	t _{EX} x (S + L _{FP})	
Cross-sectional area of NW fill over Culvert El _{BCS} (A _{NW}) =	77	sq ft
Existing Pre-Consolidation Pressure (P _{EX}) =	γ _{EX} x A _{NW} / (S + L _{FP})	
Existing Pre-Consolidation Pressure (P _{EX}) =	420	psf

CALCULATION: PROPOSED/POST-CONSTRUCTION CONSOLIDATION PRESSURE

Cross-sectional area of ES-LWA over Culvert foundation (A _{ES-LWA}) =	(S + L _{FP}) x (t _{ES-LWA}) - A	
Cross-sectional area of ES-LWA over Culvert foundation (A _{ES-LWA}) =	97.2	sq ft
Cross-sectional area of UL-FGA over Culvert foundation (A _{UL-FGA}) =	t _{UL-FGA} x (S + L _{FP})	
Cross-sectional area of UL-FGA over Culvert foundation (A _{UL-FGA}) =	0.7	sq ft
Cross-sectional area of NW fill over Culvert foundation (A _{NW}) =	t _{NW} x (S + L _{FP})	
Cross-sectional area of NW fill over Culvert foundation (A _{NW}) =	28.6	sq ft
Total Cross-sectional area: All Proposed fills (A _{PR}) =	A _{ES-LWA} + A _{UL-FGA} + A _{NW}	
Total Cross-sectional area: All Proposed fills (A _{PR}) =	126.5	sq ft
Cross-sectional area: Streambed Material (A _{SB}) =	t _{SB} x S	
Cross-sectional area: Streambed Material (A _{SB}) =	36.0	sq ft

Weighted Soil Unit Weight

Weighted Soil Density (ES-LWA, UL-FGA and NW Fills, γ _{PR}) =	(γ _{UL-FGA} x A _{UL-FGA} + γ _{ES-LWA} x A _{ES-LWA} + γ _{NW} x A _{NW}) / (A _{UL-FGA} + A _{ES-LWA} + A _{NW})	
Weighted Soil Density (ES-LWA, UL-FGA and NW Fills, γ _{PR}) =	80.6	pcf

Post-Construction Consolidation Pressure

Proposed / Post-Consolidation Pressure (P _{PR}) =	(γ _{PR} x A _{PR} + γ _{SB} x A _{SB}) / (S + L _{FP}) + γ _{LWC} x t _{LWC} + γ _{CS} x t _{CS}	
Proposed / Post-Consolidation Pressure (P _{PR}) =	842	psf



GZA
GeoEnvironmental, Inc.
 249 Vanderbilt Ave
 Norwood, MA 02062
 781-278-3700
<http://www.gza.com>

CALCULATION: AREA C3C

PROJECT: Culvert Replacement - North Street over White Brook
 LOCATION: Agawam, MA
 CALCULATED BY: MJO DATE: 4/4/2023
 CHECKED BY: 0 DATE: 1/0/1900

OBJECTIVE: Evaluate the existing preconsolidation and proposed consolidation pressures for proposed foundation section area C3C of the North Street over White Brook proposed culvert replacement.
REFERENCE: See cover.

ASSUMPTIONS AND INPUT

GENERAL ASSUMPTIONS

- See assumptions on calculation package cover page.

Existing/Pre-Construction Conditions at Proposed Culvert Area

Approx. existing ground surface elevation/EI. (E _{EX}) =	119.8	ft	Reference #5 of cover page
Existing Soil estimated unit weight (γ _{EX}) =	120	ft	Reference #3 of cover page

Proposed Culvert Dimensions

Culvert Shape =	ALSP 18'0" Span x 7'-8" Rise		Reference #5 of cover page
Culvert Span (S) =	18	ft	Reference #5 of cover page
Total Lateral footing projection beyond culvert span (L _{FP}) =	4	ft	See cover page
Rise (R) =	7.7	ft	Reference #5 of cover page
Area (A) =	104.5	sq ft	Reference #5 of cover page

Proposed Materials

Approx. proposed ground surface elevation/EI. (E _{PR}) =	128.6	ft	Reference #5 of cover page
Proposed EI. for bottom of crushed stone for foundation (E _{BES}) =	111.9	ft	Reference #5 of cover page
Unit Weight: NW fill (γ _{NW}) =	118	pcf	See cover page, topsoil
Unit Weight: ES-LWA fill (γ _{ES-LWA}) =	70	pcf	-
Unit Weight: UL-FGA fill (γ _{UL-FGA}) =	25	pcf	-
Unit Weight: Streambed Material (γ _{SB}) =	100	pcf	-
Unit Weight: Reinforced Lightweight Concrete (γ _{LWC}) =	100	pcf	-
Unit Weight: 3/4-inch Crushed Stone (γ _{CS}) =	115	pcf	-
Thickness: NW fill (t _{NW}) =	1.3	ft	See cover page
Thickness: ES-LWA fill (t _{ES-LWA}) =	9.2	ft	See cover page
Thickness: UL-FGA fill (t _{UL-FGA}) =	4.2	ft	See cover page
Thickness: Streambed Material (t _{SB}) =	2	ft	See cover page
Thickness: Reinforced Lightweight Concrete (t _{LWC}) =	1	ft	See cover page
Thickness: 3/4-inch Crushed Stone (t _{CS}) =	1	ft	See cover page

CALCULATION: EXISTING/PRE-CONSTRUCTION PRE-CONSOLIDATION PRESSURE

Existing Soil thickness (t _{EX}) =	E _{EX} - E _{BES}	ft
Existing Soil thickness (t _{EX}) =	7.9	ft
Cross-sectional area of NW fill over Culvert E _{BES} (A _{NW}) =	t _{EX} × (S + L _{FP})	
Cross-sectional area of NW fill over Culvert E _{BES} (A _{NW}) =	173.6	sq ft
Existing Pre-Consolidation Pressure (P _{EX}) =	γ _{EX} × A _{NW} / (S + L _{FP})	
Existing Pre-Consolidation Pressure (P _{EX}) =	946.7	psf

CALCULATION: PROPOSED/POST-CONSTRUCTION CONSOLIDATION PRESSURE

Cross-sectional area of ES-LWA over Culvert foundation (A _{ES-LWA}) =	(S + L _{FP}) × (t _{ES-LWA}) - A	
Cross-sectional area of ES-LWA over Culvert foundation (A _{ES-LWA}) =	97.2	sq ft
Cross-sectional area of UL-FGA over Culvert foundation (A _{UL-FGA}) =	t _{UL-FGA} × (S + L _{FP})	
Cross-sectional area of UL-FGA over Culvert foundation (A _{UL-FGA}) =	92.6	sq ft
Cross-sectional area of NW fill over Culvert foundation (A _{NW}) =	t _{NW} × (S + L _{FP})	
Cross-sectional area of NW fill over Culvert foundation (A _{NW}) =	28.6	sq ft
Total Cross-sectional area: All Proposed fills (A _{PR}) =	A _{ES-LWA} + A _{UL-FGA} + A _{NW}	
Total Cross-sectional area: All Proposed fills (A _{PR}) =	218.4	sq ft
Cross-sectional area: Streambed Material (A _{SB}) =	t _{SB} × S	
Cross-sectional area: Streambed Material (A _{SB}) =	36.0	sq ft

Weighted Soil Unit Weight

Weighted Soil Density (ES-LWA, UL-FGA and NW Fills, γ _{PR}) =	(γ _{UL-FGA} × A _{UL-FGA} + γ _{ES-LWA} × A _{ES-LWA} + γ _{NW} × A _{NW}) / (A _{UL-FGA} + A _{ES-LWA} + A _{NW})	
Weighted Soil Density (ES-LWA, UL-FGA and NW Fills, γ _{PR}) =	57.2	pcf

Post-Construction Consolidation Pressure

Proposed / Post-Consolidation Pressure (P _{PR}) =	(γ _{PR} × A _{PR} + γ _{SB} × A _{SB}) / (S + L _{FP}) + γ _{LWC} × t _{LWC} + γ _{CS} × t _{CS}	
Proposed / Post-Consolidation Pressure (P _{PR}) =	946.7	psf



Settlement Estimate - North Street over White Brook Proposed Culvert Foundation

Project:	Culvert Replacement - North Street over White Brook		
Location:	Agawam, MA		
Calculated By:	MJO	Date:	4/5/2023
Checked By:	MAR	Date:	4/12/2023

Objective: Estimate settlement of the assumed proposed mat foundation using estimated dead loads associated with the North Street over White Brook replacement culvert construction using the methodology in general accordance with MassDOT LRFD Bridge Design Manual, which references the AASHTO LRFD Bridge Design Specification, 9th Edition (2020).

Approach: Estimated primary consolidation settlement for a shallow foundation bearing on a compressible fine-grained Connecticut Valley Varved Clay (CVVC) soil stratum in general accordance with AASHTO Section 10.6.2.4.3.

- References:**
- 1) MassDOT Bridge Design Manual, 2013 with 2020 updates.
 - 2) AASHTO LRFD Bridge Design Specifications, 9th Edition, 2020.
 - 3) Subsurface conditions based on recent borings BB-01 through BB-03 completed from December 28 to 30, 2022, by Seaboard Drilling, Inc. of Springfield, Massachusetts, observed and logged by GZA. Subsurface conditions from the recent borings supplemented by subsurface conditions based on previous borings WB-1 and WB-2 completed on November 12, 2020, by Seaboard Drilling, Inc. of Springfield, Massachusetts, observed and logged by O'Rielly, Talbot & Okun.
 - 4) Footing Reaction & Consolidation Pressure Calculations prepared by GZA dated April, 2023.
 - 5) Degroot, D.J., & Lutenegeger, A.J. (2003). "Engineering Properties of Connecticut Valley Varved Clay."
 - 6) GZA calculations of CVVC clay consolidation parameters based on laboratory oedometer results published in Reference #5.
 - 7) GZA Figures comparing Atterberg Limit laboratory results from samples obtained from the borings in Reference #3 to published data from Reference #5 (attached to GZA's Bearing Capacity Calculation packet, included in this report).

Subsurface Conditions: As depicted in the attached plans in Reference #4, the proposed bottom of culvert foundation elevations for the proposed culvert range from between approximately 10 and 21 feet below proposed grades (corresponding to approximate El. range 112.5 to 118). Based on Reference #3, subsurface conditions below the proposed bottom of culvert foundation grades include approximately 17 to 34.5 feet of CVVC overlying glacial till and bedrock.

- Analysis Assumptions:**
- 1) Culvert dimensions and location as depicted in Appendix G Attachments 1 and 2.
 - 2) Culvert foundation assumed to be a 22-foot-wide continuous mat foundation as depicted in Appendix G Attachment 2.
 - 3) Fill materials (i.e. normal-weight fill, expanded shale lightweight aggregate fill, and ultra-light foamed glass aggregate) over the culvert and culvert foundation are as described in Reference #4.
 - 4) Raise-in-Grade areas and thicknesses are per the attached Figure G.4-1 by GZA, which are based on an evaluation of existing vs. proposed grades from the preliminary design plans. Also refer to GZA's Bearing Capacity calculation dated 3/30/2023.
 - 5) Consolidation parameters for the CVVC stratum at this site as calculated in Reference #7.
 - 6) Virgin compression settlement is calculated only for the portion of the culvert and fill surcharge pressures that result in a net increase in effective stress over existing conditions (areas C1V and C3V only). Recompression settlement is calculated for the portion of culvert and fill surcharge pressures that do not cause a net increase in effective stress over existing conditions.

Attachments: Calculations Summary Tables by GZA, Settlement Evaluation Plan by GZA, Calculations determining clay consolidation parameters from published documents,

LRFD Settlement Evaluation - North Street over White Brook Proposed Culvert Foundation

Project: Culvert Replacement - North Street over White Brook
 Location: Agawam, MA
 Assumptions: See Cover
 References: See Cover

Calculated By: MJO Date: 4/5/2023

Checked By: MAR Date: 4/12/2023

SETTLEMENT EVALUATION RESULTS: CULVERT FOUNDATION LOADS																						
Load Area No.	Case	Weighted Unit Wt, γ (pcf)	Soil Height, H (ft)	Assumed Fdn: 1' x 22' wide mat		Load Area Coordinates				Avg. Bearing EL. (ft)	Settlements Computed at the indicated grid coordinate points using SAF-I for Culvert Mat Slab Loads (inches)											
				Area Avg. B.P. from DL (ksf)	Area Avg. B.P. from DL (psf)	SW (x)	SW (y)	NE (x)	NE (y)		(18, 125.5)	(18,135.8)	(18, 145)	(7, 109.8)	(7, 124.8)	(7, 138)	(18, 37)	(18, 47.5)	(7, 32)	(7, 39.5)	(18,86.5)	(7,86.5)
C1 (Inlet)	HP, recomp. LP, recomp.	45 79	19 19	0.51	510	7	28	29	67	117								0.76	0.81	0.41	0.48	
C1V (Inlet)	Virgin	65.6	11.4	0.09	90	7	32	33	37	117							0.34	0.05	0.19	0.11		
C2 (Arch)	HP, recomp. LP, recomp.	45 47	19.5 18.5	0.49	490	7	67	29	106	115.3	0.02			0.11	0.02		0.01	0.02			0.62	0.37
C3 (Outlet)	HP, recomp. LP, recomp.	44.8 76	18.5 10	0.54	540	7	106	29	145	113.5	0.38	0.37	0.2	0.18	0.21	0.2						
C3V (Outlet)	Virgin	57.2	14.7	0.21	211	7	135.8	34.5	145	113.5	1.06	1.03	0.54	0.49	0.57	0.53						
Avg. Unit Weight: C1 (pcf) =		62																				
Avg. Unit Weight: C3 (pcf) =		60																				

SETTLEMENT EVALUATION RESULTS: RAISE-IN-GRADE (RIG) LOADS																						
Area	Weighted Unit Wt, γ (pcf) LW Fills	H (ft)	Avg. B.P. (psf)	Load Area Coordinates				Prop. EL. High (ft)	Prop. EL. Low (ft)	Avg. Bearing EL. (ft)	Settlements Computed at the indicated grid coordinate points using SAF-I for RIG Fill Area (FA) Loads (inches)											
				SW (x)	SW (y)	NE (x)	NE (y)				(18, 125.5)	(18,135.8)	(18, 145)	(7, 109.8)	(7, 124.8)	(7, 138)	(18, 37)	(18, 47.5)	(7, 32)	(7, 39.5)	(18,86.5)	(7,86.5)
FA1	60	4	242	-33.5	131	1.5	156	136	123	125.5	0.01	0.01	0.01	0	0.02	0.05	0	0	0	0	0	0
FA2a	60	8	483	1.5	131	7	145	131	123	119	0	0.01	0.01	0	0.02	0.18	0	0	0	0	0	0
FA2b	60	8	483	1.5	145	34.5	149	131	123	119	0	0.02	0.17	0	0	0.03	0	0	0	0	0	0
FA2c	60	8	483	29	131	34.5	145	131	123	119	0	0.01	0.01	0	0	0	0	0	0	0	0	0
FA3	60	4	242	34.5	131	49	156	132.5	123	123.75	0	0.01	0.01	0	0	0	0	0	0	0	0	0
FA4a	60	5	302	-20	118.5	7	131	136	131	128.5	0.01	0.01	0.02	0	0	0	0	0	0	0	0	0
FA4b	60	5	302	29	118.5	47	131	136	131	128.5	0.02	0.01	0.01	0	0	0	0	0	0	0	0	0
FA5a	60	3	181	-11	101	7	118.5	136	133	131.5	0.01	0	0	0.05	0.02	0.01	0	0	0	0	0.01	0.01
FA5b	60	3	181	29	101	45	118.5	136	133	131.5	0.01	0	0	0	0	0	0	0	0	0	0.01	0
FA6a	62	6	371	2.8	28	7	36	131	129	126.5							0.04	0.02	0.09	0.07	0	0
FA6b	62	6	371	29	28	33	36	131	129	126.5							0					
FA7a	62	3	186	3	36	7	43	133	131	126.5												
FA7b	62	3	186	29	36	33	43	133	131	126.5												
Settlement Totals: Culvert Foundation Load and RIG Load Areas (inches):											1.46	0.74	0.78	0.8	0.73		0.88	0.6	0.59	0.62	0.37	

Notes: 1) Acronyms/Shorthand: HP = High Point, LP = Low Point, recomp. = recompression, Fdn = foundation, DL = dead load, Avg. = Average, B.P. = bearing pressure, pcf = pounds per cubic foot, psf = pounds per square foot, ft = foot, EL. = Elevation (referenced to the North American Vertical Datum of 1988), Wt = weight, SW = southwest, NE = northeast, FA = Fill Area (for raise-in-grade loads), LW = lightweight, Prop. = Proposed.

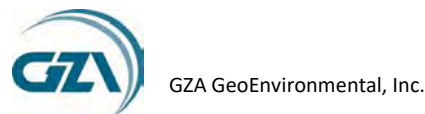

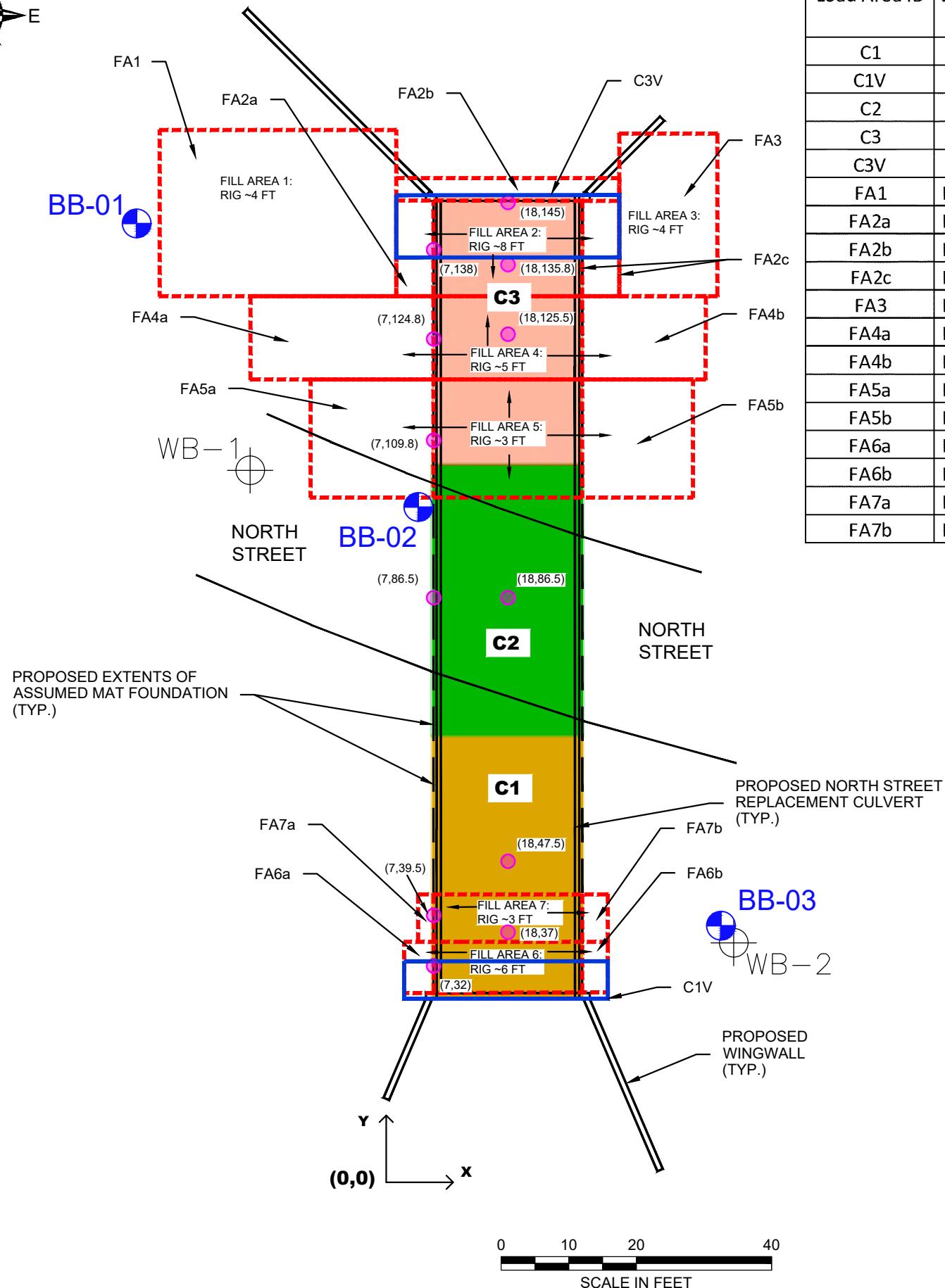
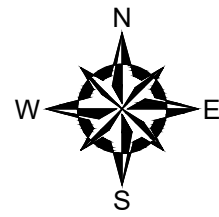

Load Area ID	Load Area Type	Average Bearing El. (ft)	Settlement Evaluation Type (virgin/recompression)
C1	Culvert	117	recompression
C1V	Culvert	117	virgin
C2	Culvert	115.3	recompression
C3	Culvert	113.5	recompression
C3V	Culvert	113.5	virgin
FA1	Raise-in-Grade	125.5	recompression
FA2a	Raise-in-Grade	119	recompression
FA2b	Raise-in-Grade	119	recompression
FA2c	Raise-in-Grade	119	recompression
FA3	Raise-in-Grade	123.75	recompression
FA4a	Raise-in-Grade	128.5	recompression
FA4b	Raise-in-Grade	128.5	recompression
FA5a	Raise-in-Grade	131.5	recompression
FA5b	Raise-in-Grade	131.5	recompression
FA6a	Raise-in-Grade	126.5	recompression
FA6b	Raise-in-Grade	126.5	recompression
FA7a	Raise-in-Grade	126.5	recompression
FA7b	Raise-in-Grade	126.5	recompression

LEGEND:

- TEST BORING PERFORMED BY SEABOARD DRILLING, INC. OF SPRINGFIELD, MASSACHUSETTS ON DECEMBER 28 TO 30, 2022. OBSERVED AND LOGGED BY GZA PERSONNEL.
- BB-01**
- BORING PERFORMED BY SEABOARD DRILLING, INC. OF SPRINGFIELD, MASSACHUSETTS ON NOVEMBER 12, 2020. OBSERVED AND LOGGED BY O'REILLY, TALBOT & OKUN ASSOCIATES, INC. (OTO).
- WB-2**
- SETTLEMENT EVALUATION POINT
- SETTLEMENT EVALUATION AREA AT PROPOSED CULVERT

NOTES:

1. BASE MAP DEVELOPED FROM AN AUTOCAD DRAWING FILE PREPARED BY WOODARD & CURRAN (W&C) ENTITLED "190299K NORTH STREET", TRANSMITTED TO GZA ON JANUARY 10, 2023.
2. PROPOSED CULVERT, HEADWALL, WINGWALL, AND NORTH STREET LOCATIONS WERE APPROXIMATED FROM ELECTRONIC IMAGE FILE "NORTH STREET 60% DESIGN DRAWINGS" OF DRAWING C-102, SHEET 5 OF 8, TITLED SITE LAYOUT PLAN, PREPARED BY W&C, ORIGINAL SCALE 1"=20', DATED OCTOBER, 2022, AND TRANSMITTED TO GZA ON OCTOBER 28, 2022.
3. THE BB-SERIES EXPLORATION LOCATIONS ARE BASED ON TAPED MEASUREMENTS AND/OR LINE OF SIGHT FROM EXISTING SITE FEATURES. THE DATA SHOULD BE CONSIDERED ACCURATE ONLY TO THE DEGREE IMPLIED BY THE METHOD USED. BORING LOCATIONS SHOWN HEREIN SHOULD BE CONSIDERED APPROXIMATE.
4. THE WB-SERIES EXPLORATION LOCATIONS WERE OBTAINED FROM THE BASE MAP FILE REFERENCED IN NOTE #1.
5. THE PROPOSED CULVERT FOUNDATION AREA WAS APPROXIMATED BASED ON AN ASSUMED 22-FOOT-WIDE MAT FOUNDATION.
6. THE FILL AREAS AND RAISE-IN-GRADE (RIG) AMOUNTS WERE APPROXIMATED BASED ON EXISTING AND PROPOSED TOPOGRAPHY SHOWN ON A PRELIMINARY DESIGN DRAWING PREPARED BY W&C ENTITLED "SITE LAYOUT PLAN," DATED FEBRUARY 16, 2023.
7. REFER TO THE GZA SETTLEMENT EVALUATION CALCULATION DATED 4/11/2023 FOR MORE INFORMATION ABOUT THE EMBEDDED TABLE.

UNLESS SPECIFICALLY STATED BY WRITTEN AGREEMENT, THIS DRAWING IS THE SOLE PROPERTY OF GZA GEOENVIRONMENTAL, INC. (GZA). THE INFORMATION SHOWN ON THE DRAWING IS SOLELY FOR USE BY GZA'S CLIENT OR THE CLIENT'S DESIGNATED REPRESENTATIVE FOR THE SPECIFIC PROJECT AND LOCATION IDENTIFIED ON THE DRAWING. THE DRAWING SHALL NOT BE TRANSFERRED, REUSED, COPIED, OR ALTERED IN ANY MANNER FOR USE AT ANY OTHER LOCATION OR FOR ANY OTHER PURPOSE WITHOUT THE PRIOR WRITTEN CONSENT OF GZA. ANY TRANSFER, REUSE, OR MODIFICATION TO THE DRAWING BY THE CLIENT OR OTHERS, WITHOUT THE PRIOR WRITTEN EXPRESS CONSENT OF GZA, WILL BE AT THE USER'S SOLE RISK AND WITHOUT ANY RISK OR LIABILITY TO GZA.

**PROPOSED CULVERT REPLACEMENT
NORTH STREET OVER WHITE BROOK
AGAWAM, MASSACHUSETTS**

**SETTLEMENT EVALUATION
LAYOUT PLAN**

PREPARED BY: GZA GeoEnvironmental, Inc. Engineers and Scientists www.gza.com		PREPARED FOR: Woodard & Curran	
PROJ MGR: MJO	REVIEWED BY: MAR	CHECKED BY: TMK	FIGURE
DESIGNED BY: MJO	DRAWN BY: MJO	SCALE: AS SHOWN	G.4-1
DATE: APRIL 2023	PROJECT NO. 01.0177018.00	REVISION NO. 0	

Geology and Engineering Properties of Connecticut Valley Varved Clay

D.J. DeGroot & A.J. Lutenecker

University of Massachusetts Amherst, Amherst, MA, USA

[Reference: DeGroot, D.J. and Lutenecker, A.J. (2003). "Engineering Properties of Connecticut Valley Varved Clay," *Characterisation and Engineering Properties of Natural Soils*, Balkema, 1:695-724.]

ABSTRACT: This paper describes the geology and geotechnical engineering properties of Connecticut Valley Varved Clay (CVVC). Results from soil sampling, in situ testing, and laboratory testing conducted during the past 10 years for a deposit of CVVC at the National Geotechnical Experimentation Site in Amherst, Massachusetts, USA are presented. CVVC is a lacustrine soil deposited approximately 15,000 years ago during retreat of the Laurentide Ice Sheet. The soil's most distinguishing feature is its varved nature with alternating layers of silt and clay. This gives CVVC several unique engineering properties making it a challenging soil for engineering design. CVVC has hydraulic conductivity and undrained shear strength anisotropy that far exceeds that of most other soils. The strength of the soil for shearing along the horizontal varves is much less than that for shearing across the varves. The paper presents data on these and other soil classification, index, and engineering properties based on in situ measurements and laboratory test results.

1 INTRODUCTION

This paper describes the geology and engineering properties of Connecticut Valley Varved Clay (CVVC) and the geotechnical engineering design challenges in dealing with this unique soil. CVVC is a lacustrine soil deposit that was formed approximately 15,000 calendar years ago in glacial lake Hitchcock during the retreat of the late Pleistocene ice sheet in New England, USA. The main distinguishing feature of the deposit, as in most glacial lake deposits, is the alternating layers of clay and silt-fine sand. The material for these deposits entered Glacial Lake Hitchcock by melt water streams formed from the retreating glacier. During the warm summer seasons, the fine sand and silt size particles from the outwash deposited on the lake bottom whereas during the calmer winter seasons, when the lake surface was frozen, the clay particles settled out of suspension. The resulting pair of layers, which is known as a varve, represents one year of deposition. The thickness of the varves varies considerably depending on location within the lake and time of deposition ranging from a few millimeters to as large as 1 m thick. Typical deposits of CVVC contain from several hundred to several thousand varves.

Varved clay deposits are commonly found in glaciated regions of North America and Europe north of the 40th parallel and are a prolific source of serious construction difficulties (Terzaghi et al. 1996). There are extensive deposits of varved clays associated with glacial lakes throughout the northeast and north central United States (e.g. Lobdell 1970, Seymour-Jones 1984, Baker & Marr 1976, Vaghar et al. 1992, Rominger & Rutledge 1952, Parsons 1976, Leathers & Ladd 1978) and eastern Canada (e.g. Milligan et al. 1962, Kenney 1976, Chan & Kenney 1973). The layered nature of these soils requires special design considerations for geotechnical problems. The strength of the soil for shearing along the horizontal varves is much less than that for shearing across the varves. Because of the silt layers, the horizontal hydraulic conductivity can be far greater than that in the vertical direction. Laboratory testing of varved clays is problematic because results depend greatly on specimen size and the relative portions of the silt and clay layers

6.2 Stress History and Compressibility

The stress history of CVVC can vary significantly depending on site-specific geologic history. In most cases, however, the soil is generally overconsolidated at shallow depths (i.e. "crust") due to one or more mechanisms such as erosion, fluctuating water table, desiccation, cementation, oxidation/reduction, and freeze-thaw. At greater depths the soil is typically lightly overconsolidated. At these depths, some of the possible mechanisms are the effects of surface erosion, cementation and aging. Figure 13 plots typical compression curves from incremental load (IL) oedometer tests on samples from different depths. Figure 14 plots stress history data as determined from the results of IL and constant rate of strain (CRS) consolidation tests on tube and block samples. The volumetric strain (ϵ_{vol}) values plotted in Figure 14a correspond to the laboratory recompression strain to σ'_{vo} as measured in the consolidation tests.

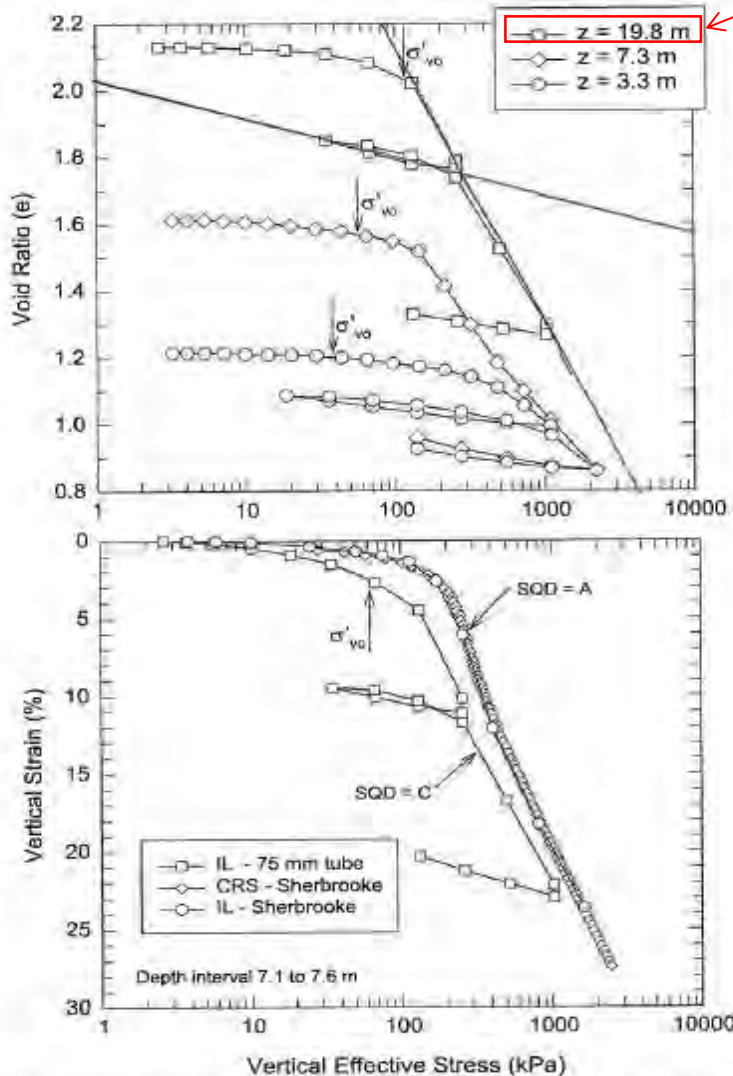

Figure 13. One-Dimensional Compression Curves: a) From Different Depths, b) Tube versus Block Samples.

GZA calculations by MAR on 2/15/2023, checked by MJO on 4/6/2023:

Conservatively used compression curve for Z = 19.8 m

- $C_c = \Delta e / \log(\sigma'_2 / \sigma'_1)$
 $\Delta e = 2.2 - 0.8 = 1.4$
 $\Delta \sigma' = 4000 - 70 = 3,930 \text{ kPa}$
 $\log(\sigma'_2 / \sigma'_1) = \log(4000/70) = \log(57.14) = 1.76$
 $C_c = 1.4 / 1.76 = 0.795$
- $CR = C_c / (1 + e_o)$
 $e_o \sim 2.14$
 $CR = 0.795 / (1 + 2.14) = 0.25$
- $C_r = \Delta e_{RR} / \log(\sigma'_2 / \sigma'_1)$
 $\Delta e_{RR} = (1.57 - 2.03) - 1 = 0.46$
 $\sigma'_2 = 10,000$
 $\sigma'_1 = 1$
 $\log(\sigma'_2 / \sigma'_1) = 4$
 $C_r = 0.46 / 4 = 0.115$
- $RR = C_r / (1 + e_o) = 0.115 / 3.14$
 $RR \sim 0.037$

RECTANGULAR LOADS

Project Name: North St Culvert, Agawam Project Number : 177018.00
 Client : Woodard-Curran Project Manager: MJO
 Date : 4/6/2023 Computed by : MJO

Increment of stresses obtained using : Boussinesq

Settlement for X = 7.00 (ft) Y = 109.80 (ft)

Footing #	Corner Point P1		Corner Point P2		Load (psf)
	X1(ft)	Y1(ft)	X2(ft)	Y2(ft)	
1	7.00	106.00	29.00	145.00	540.00

Foundation Elev. = 113.50 (ft) Ground Surface Elev.= 136.50 (ft)
 Water table Elev. = 118.00 (ft) Unit weight of Wat. = 62.40 (pcf)

Nº.	Layer Type	Thick. (ft)	Comp. Ratio	Recomp. Ratio	Swell. Ratio	Unit Weight (pcf)	Primary Settlement (in.)	Secondary Settlement (in.)
1	INCOMP.	16.5				125.00	0.00	0.00
2	COMP.	19.0	0.037	0.037	0.037	118.00	0.18	0.00
3	INCOMP.	31.0				130.00	0.00	0.00
Total Settlement =							0.18	0.00

N§.	Sublayer		Soil Stresses			Settlement (in.)
	Thick. (ft)	Elev. (ft)	Initial (psf)	Increment (psf)	Max.Past Press. (psf)	
1	INCOMP.					
2	Sublayer over foundation Elev.					
3	Sublayer over foundation Elev.					
4	Sublayer over foundation Elev.					
5	1.10	112.95	2579.28	269.83	2579.28	0.02
6	1.90	111.45	2662.68	263.33	2662.68	0.03
7	1.90	109.55	2768.32	243.35	2768.32	0.03
8	1.90	107.65	2873.96	222.45	2873.96	0.03
9	1.90	105.75	2979.60	205.25	2979.60	0.02
10	1.90	103.85	3085.24	191.32	3085.24	0.02
11	1.90	101.95	3190.88	179.58	3190.88	0.02
12	INCOMP.					
Total Settlement =						0.18 (in.)

RECTANGULAR LOADS

Project Name: North St Culvert, Agawam Project Number : 177018.00
 Client : Woodard-Curran Project Manager: MJO
 Date : 4/6/2023 Computed by : MJO

Increment of stresses obtained using : Boussinesq

Settlement for X = 7.00 (ft) Y = 124.80 (ft)

Footing #	Corner Point P1		Corner Point P2		Load (psf)
	X1(ft)	Y1(ft)	X2(ft)	Y2(ft)	
1	7.00	106.00	29.00	145.00	540.00

Foundation Elev. = 113.50 (ft) Ground Surface Elev.= 136.50 (ft)
 Water table Elev. = 118.00 (ft) Unit weight of Wat. = 62.40 (pcf)

Nº.	Layer Type	Thick. (ft)	Comp. Ratio	Recomp. Ratio	Swell. Ratio	Unit Weight (pcf)	Primary Settlement (in.)	Secondary Settlement (in.)
1	INCOMP.	16.5				125.00	0.00	0.00
2	COMP.	19.0	0.037	0.037	0.037	118.00	0.21	0.00
3	INCOMP.	31.0				130.00	0.00	0.00
Total Settlement =							0.21	0.00

N§.	Sublayer		Soil Stresses			Settlement (in.)
	Thick. (ft)	Elev. (ft)	Initial (psf)	Increment (psf)	Max.Past Press. (psf)	
1	INCOMP.					
2	Sublayer over foundation Elev.					
3	Sublayer over foundation Elev.					
4	Sublayer over foundation Elev.					
5	1.10	112.95	2579.28	270.00	2579.28	0.02
6	1.90	111.45	2662.68	269.80	2662.68	0.04
7	1.90	109.55	2768.32	268.63	2768.32	0.03
8	1.90	107.65	2873.96	265.78	2873.96	0.03
9	1.90	105.75	2979.60	260.88	2979.60	0.03
10	1.90	103.85	3085.24	253.87	3085.24	0.03
11	1.90	101.95	3190.88	244.97	3190.88	0.03
12	INCOMP.					
Total Settlement =						0.21 (in.)

RECTANGULAR LOADS

Project Name: North St Culvert, Agawam Project Number : 177018.00
 Client : Woodard-Curran Project Manager: MJO
 Date : 4/6/2023 Computed by : MJO

Increment of stresses obtained using : Boussinesq

Settlement for X = 7.00 (ft) Y = 138.00 (ft)

Footing #	Corner Point P1		Corner Point P2		Load (psf)
	X1(ft)	Y1(ft)	X2(ft)	Y2(ft)	
1	7.00	106.00	29.00	145.00	540.00

Foundation Elev. = 113.50 (ft) Ground Surface Elev.= 136.50 (ft)
 Water table Elev. = 118.00 (ft) Unit weight of Wat. = 62.40 (pcf)

Nº.	Layer Type	Thick. (ft)	Comp. Ratio	Recomp. Ratio	Swell. Ratio	Unit Weight (pcf)	Primary Settlement (in.)	Secondary Settlement (in.)
1	INCOMP.	16.5				125.00	0.00	0.00
2	COMP.	19.0	0.037	0.037	0.037	118.00	0.20	0.00
3	INCOMP.	31.0				130.00	0.00	0.00
Total Settlement =							0.20	0.00

N§.	Sublayer		Soil Stresses			Settlement (in.)
	Thick. (ft)	Elev. (ft)	Initial (psf)	Increment (psf)	Max.Past Press. (psf)	
1	INCOMP.					
2	Sublayer over foundation Elev.					
3	Sublayer over foundation Elev.					
4	Sublayer over foundation Elev.					
5	1.10	112.95	2579.28	269.97	2579.28	0.02
6	1.90	111.45	2662.68	268.63	2662.68	0.04
7	1.90	109.55	2768.32	262.14	2768.32	0.03
8	1.90	107.65	2873.96	250.93	2873.96	0.03
9	1.90	105.75	2979.60	237.54	2979.60	0.03
10	1.90	103.85	3085.24	223.78	3085.24	0.03
11	1.90	101.95	3190.88	210.45	3190.88	0.02
12	INCOMP.					
Total Settlement =						0.20 (in.)

RECTANGULAR LOADS

Project Name: North St Culvert, Agawam Project Number : 177018.00
 Client : Woodard-Curran Project Manager: MJO
 Date : 4/6/2023 Computed by : MJO

Increment of stresses obtained using : Boussinesq

Settlement for X = 18.00 (ft) Y = 125.50 (ft)

Footing #	Corner Point P1		Corner Point P2		Load (psf)
	X1(ft)	Y1(ft)	X2(ft)	Y2(ft)	
1	7.00	106.00	29.00	145.00	540.00

Foundation Elev. = 113.50 (ft) Ground Surface Elev.= 136.50 (ft)
 Water table Elev. = 118.00 (ft) Unit weight of Wat. = 62.40 (pcf)

Nº.	Layer Type	Thick. (ft)	Comp. Ratio	Recomp. Ratio	Swell. Ratio	Unit Weight (pcf)	Primary Settlement (in.)	Secondary Settlement (in.)
1	INCOMP.	16.5				125.00	0.00	0.00
2	COMP.	19.0	0.037	0.037	0.037	118.00	0.38	0.00
3	INCOMP.	31.0				130.00	0.00	0.00
Total Settlement =							0.38	0.00

N§.	Sublayer		Soil Stresses			Settlement (in.)
	Thick. (ft)	Elev. (ft)	Initial (psf)	Increment (psf)	Max.Past Press. (psf)	
1	INCOMP.					
2	Sublayer over foundation Elev.					
3	Sublayer over foundation Elev.					
4	Sublayer over foundation Elev.					
5	1.10	112.95	2579.28	539.97	2579.28	0.04
6	1.90	111.45	2662.68	538.43	2662.68	0.07
7	1.90	109.55	2768.32	529.86	2768.32	0.06
8	1.90	107.65	2873.96	511.54	2873.96	0.06
9	1.90	105.75	2979.60	484.62	2979.60	0.06
10	1.90	103.85	3085.24	452.11	3085.24	0.05
11	1.90	101.95	3190.88	417.09	3190.88	0.05
12	INCOMP.					
Total Settlement =						0.38 (in.)

RECTANGULAR LOADS

Project Name: North St Culvert, Agawam Project Number : 177018.00
 Client : Woodard-Curran Project Manager: MJO
 Date : 4/6/2023 Computed by : MJO

Increment of stresses obtained using : Boussinesq

Settlement for X = 18.00 (ft) Y = 135.80 (ft)

Footing #	Corner Point P1		Corner Point P2		Load (psf)
	X1(ft)	Y1(ft)	X2(ft)	Y2(ft)	
1	7.00	106.00	29.00	145.00	540.00

Foundation Elev. = 113.50 (ft) Ground Surface Elev.= 136.50 (ft)
 Water table Elev. = 118.00 (ft) Unit weight of Wat. = 62.40 (pcf)

Nº.	Layer Type	Thick. (ft)	Comp. Ratio	Recomp. Ratio	Swell. Ratio	Unit Weight (pcf)	Primary Settlement (in.)	Secondary Settlement (in.)
1	INCOMP.	16.5				125.00	0.00	0.00
2	COMP.	19.0	0.037	0.037	0.037	118.00	0.37	0.00
3	INCOMP.	31.0				130.00	0.00	0.00
Total Settlement =							0.37	0.00

N§.	Sublayer		Soil Stresses			Settlement (in.)
	Thick. (ft)	Elev. (ft)	Initial (psf)	Increment (psf)	Max.Past Press. (psf)	
1	INCOMP.					
2	Sublayer over foundation Elev.					
3	Sublayer over foundation Elev.					
4	Sublayer over foundation Elev.					
5	1.10	112.95	2579.28	539.95	2579.28	0.04
6	1.90	111.45	2662.68	537.58	2662.68	0.07
7	1.90	109.55	2768.32	524.80	2768.32	0.06
8	1.90	107.65	2873.96	499.02	2873.96	0.06
9	1.90	105.75	2979.60	463.65	2979.60	0.05
10	1.90	103.85	3085.24	423.88	3085.24	0.05
11	1.90	101.95	3190.88	383.87	3190.88	0.04
12	INCOMP.					
Total Settlement =						0.37 (in.)

RECTANGULAR LOADS

Project Name: North St Culvert, Agawam Project Number : 177018.00
 Client : Woodard-Curran Project Manager: MJO
 Date : 4/6/2023 Computed by : MJO

Increment of stresses obtained using : Boussinesq

Settlement for X = 18.00 (ft) Y = 145.00 (ft)

Footing #	Corner Point P1		Corner Point P2		Load (psf)
	X1(ft)	Y1(ft)	X2(ft)	Y2(ft)	
1	7.00	106.00	29.00	145.00	540.00

Foundation Elev. = 113.50 (ft) Ground Surface Elev.= 136.50 (ft)
 Water table Elev. = 118.00 (ft) Unit weight of Wat. = 62.40 (pcf)

Nº.	Layer Type	Thick. (ft)	Comp. Ratio	Recomp. Ratio	Swell. Ratio	Unit Weight (pcf)	Primary Settlement (in.)	Secondary Settlement (in.)
1	INCOMP.	16.5				125.00	0.00	0.00
2	COMP.	19.0	0.037	0.037	0.037	118.00	0.20	0.00
3	INCOMP.	31.0				130.00	0.00	0.00
Total Settlement =							0.20	0.00

N§.	Sublayer		Soil Stresses			Settlement (in.)
	Thick. (ft)	Elev. (ft)	Initial (psf)	Increment (psf)	Max.Past Press. (psf)	
1	INCOMP.					
2	Sublayer over foundation Elev.					
3	Sublayer over foundation Elev.					
4	Sublayer over foundation Elev.					
5	1.10	112.95	2579.28	269.99	2579.28	0.02
6	1.90	111.45	2662.68	269.28	2662.68	0.04
7	1.90	109.55	2768.32	265.38	2768.32	0.03
8	1.90	107.65	2873.96	257.13	2873.96	0.03
9	1.90	105.75	2979.60	245.17	2979.60	0.03
10	1.90	103.85	3085.24	230.95	3085.24	0.03
11	1.90	101.95	3190.88	215.86	3190.88	0.02
12	INCOMP.					
Total Settlement =						0.20 (in.)

RECTANGULAR LOADS

Project Name: North St Culvert, Agawam Project Number : 177018.00
 Client : Woodard-Curran Project Manager: MJO
 Date : 4/6/2023 Computed by : MJO

Increment of stresses obtained using : Boussinesq

Settlement for X = 7.00 (ft) Y = 109.80 (ft)

Footing #	Corner Point P1		Corner Point P2		Load (psf)
	X1(ft)	Y1(ft)	X2(ft)	Y2(ft)	
1	7.00	106.00	29.00	145.00	211.00

Foundation Elev. = 113.50 (ft) Ground Surface Elev.= 136.50 (ft)
 Water table Elev. = 118.00 (ft) Unit weight of Wat. = 62.40 (pcf)

Nº.	Layer Type	Thick. (ft)	Comp. Ratio	Recomp. Ratio	Swell. Ratio	Unit Weight (pcf)	Primary Settlement (in.)	Secondary Settlement (in.)
1	INCOMP.	16.5				125.00	0.00	0.00
2	COMP.	19.0	0.250	0.037	0.037	118.00	0.49	0.00
3	INCOMP.	31.0				130.00	0.00	0.00
Total Settlement =							0.49	0.00

N§.	Sublayer		Soil Stresses			Settlement (in.)
	Thick. (ft)	Elev. (ft)	Initial (psf)	Increment (psf)	Max.Past Press. (psf)	
1	INCOMP.					
2	Sublayer over foundation Elev.					
3	Sublayer over foundation Elev.					
4	Sublayer over foundation Elev.					
5	1.10	112.95	2579.28	105.43	2579.28	0.06
6	1.90	111.45	2662.68	102.89	2662.68	0.09
7	1.90	109.55	2768.32	95.09	2768.32	0.08
8	1.90	107.65	2873.96	86.92	2873.96	0.07
9	1.90	105.75	2979.60	80.20	2979.60	0.07
10	1.90	103.85	3085.24	74.76	3085.24	0.06
11	1.90	101.95	3190.88	70.17	3190.88	0.05
12	INCOMP.					
Total Settlement =						0.49 (in.)

RECTANGULAR LOADS

Project Name: North St Culvert, Agawam Project Number : 177018.00
 Client : Woodard-Curran Project Manager: MJO
 Date : 4/6/2023 Computed by : MJO

Increment of stresses obtained using : Boussinesq

Settlement for X = 7.00 (ft) Y = 124.80 (ft)

Footing #	Corner Point P1		Corner Point P2		Load (psf)
	X1(ft)	Y1(ft)	X2(ft)	Y2(ft)	
1	7.00	106.00	29.00	145.00	211.00

Foundation Elev. = 113.50 (ft) Ground Surface Elev.= 136.50 (ft)
 Water table Elev. = 118.00 (ft) Unit weight of Wat. = 62.40 (pcf)

Nº.	Layer Type	Thick. (ft)	Comp. Ratio	Recomp. Ratio	Swell. Ratio	Unit Weight (pcf)	Primary Settlement (in.)	Secondary Settlement (in.)
1	INCOMP.	16.5				125.00	0.00	0.00
2	COMP.	19.0	0.250	0.037	0.037	118.00	0.57	0.00
3	INCOMP.	31.0				130.00	0.00	0.00
Total Settlement =							0.57	0.00

N§.	Sublayer		Soil Stresses			Settlement (in.)
	Thick. (ft)	Elev. (ft)	Initial (psf)	Increment (psf)	Max.Past Press. (psf)	
1	INCOMP.					
2	Sublayer over foundation Elev.					
3	Sublayer over foundation Elev.					
4	Sublayer over foundation Elev.					
5	1.10	112.95	2579.28	105.50	2579.28	0.06
6	1.90	111.45	2662.68	105.42	2662.68	0.10
7	1.90	109.55	2768.32	104.96	2768.32	0.09
8	1.90	107.65	2873.96	103.85	2873.96	0.09
9	1.90	105.75	2979.60	101.93	2979.60	0.08
10	1.90	103.85	3085.24	99.20	3085.24	0.08
11	1.90	101.95	3190.88	95.72	3190.88	0.07
12	INCOMP.					
Total Settlement =						0.57 (in.)

RECTANGULAR LOADS

Project Name: North St Culvert, Agawam Project Number : 177018.00
 Client : Woodard-Curran Project Manager: MJO
 Date : 4/6/2023 Computed by : MJO

Increment of stresses obtained using : Boussinesq

Settlement for X = 7.00 (ft) Y = 138.00 (ft)

Footing #	Corner Point P1		Corner Point P2		Load (psf)
	X1(ft)	Y1(ft)	X2(ft)	Y2(ft)	
1	7.00	106.00	29.00	145.00	211.00

Foundation Elev. = 113.50 (ft) Ground Surface Elev.= 136.50 (ft)
 Water table Elev. = 118.00 (ft) Unit weight of Wat. = 62.40 (pcf)

Nº.	Layer Type	Thick. (ft)	Comp. Ratio	Recomp. Ratio	Swell. Ratio	Unit Weight (pcf)	Primary Settlement (in.)	Secondary Settlement (in.)
1	INCOMP.	16.5				125.00	0.00	0.00
2	COMP.	19.0	0.250	0.037	0.037	118.00	0.53	0.00
3	INCOMP.	31.0				130.00	0.00	0.00
Total Settlement =							0.53	0.00

N§.	Sublayer		Soil Stresses			Settlement (in.)
	Thick. (ft)	Elev. (ft)	Initial (psf)	Increment (psf)	Max.Past Press. (psf)	
1	INCOMP.					
2	Sublayer over foundation Elev.					
3	Sublayer over foundation Elev.					
4	Sublayer over foundation Elev.					
5	1.10	112.95	2579.28	105.49	2579.28	0.06
6	1.90	111.45	2662.68	104.96	2662.68	0.10
7	1.90	109.55	2768.32	102.43	2768.32	0.09
8	1.90	107.65	2873.96	98.05	2873.96	0.08
9	1.90	105.75	2979.60	92.82	2979.60	0.08
10	1.90	103.85	3085.24	87.44	3085.24	0.07
11	1.90	101.95	3190.88	82.23	3190.88	0.06
12	INCOMP.					
Total Settlement =						0.53 (in.)

RECTANGULAR LOADS

Project Name: North St Culvert, Agawam Project Number : 177018.00
 Client : Woodard-Curran Project Manager: MJO
 Date : 4/6/2023 Computed by : MJO

Increment of stresses obtained using : Boussinesq

Settlement for X = 18.00 (ft) Y = 125.50 (ft)

Footing #	Corner Point P1		Corner Point P2		Load (psf)
	X1(ft)	Y1(ft)	X2(ft)	Y2(ft)	
1	7.00	106.00	29.00	145.00	211.00

Foundation Elev. = 113.50 (ft) Ground Surface Elev.= 136.50 (ft)
 Water table Elev. = 118.00 (ft) Unit weight of Wat. = 62.40 (pcf)

Nº.	Layer Type	Thick. (ft)	Comp. Ratio	Recomp. Ratio	Swell. Ratio	Unit Weight (pcf)	Primary Settlement (in.)	Secondary Settlement (in.)
1	INCOMP.	16.5				125.00	0.00	0.00
2	COMP.	19.0	0.250	0.037	0.037	118.00	1.06	0.00
3	INCOMP.	31.0				130.00	0.00	0.00
Total Settlement =							1.06	0.00

N§.	Sublayer		Soil Stresses			Settlement (in.)
	Thick. (ft)	Elev. (ft)	Initial (psf)	Increment (psf)	Max.Past Press. (psf)	
1	INCOMP.					
2	Sublayer over foundation Elev.					
3	Sublayer over foundation Elev.					
4	Sublayer over foundation Elev.					
5	1.10	112.95	2579.28	210.99	2579.28	0.11
6	1.90	111.45	2662.68	210.39	2662.68	0.19
7	1.90	109.55	2768.32	207.04	2768.32	0.18
8	1.90	107.65	2873.96	199.88	2873.96	0.17
9	1.90	105.75	2979.60	189.36	2979.60	0.15
10	1.90	103.85	3085.24	176.66	3085.24	0.14
11	1.90	101.95	3190.88	162.97	3190.88	0.12
12	INCOMP.					
Total Settlement =						1.06 (in.)

RECTANGULAR LOADS

Project Name: North St Culvert, Agawam Project Number : 177018.00
 Client : Woodard-Curran Project Manager: MJO
 Date : 4/6/2023 Computed by : MJO

Increment of stresses obtained using : Boussinesq

Settlement for X = 18.00 (ft) Y = 135.80 (ft)

Footing #	Corner Point P1		Corner Point P2		Load (psf)
	X1(ft)	Y1(ft)	X2(ft)	Y2(ft)	
1	7.00	106.00	29.00	145.00	211.00

Foundation Elev. = 113.50 (ft) Ground Surface Elev.= 136.50 (ft)
 Water table Elev. = 118.00 (ft) Unit weight of Wat. = 62.40 (pcf)

Nº.	Layer Type	Thick. (ft)	Comp. Ratio	Recomp. Ratio	Swell. Ratio	Unit Weight (pcf)	Primary Settlement (in.)	Secondary Settlement (in.)
1	INCOMP.	16.5				125.00	0.00	0.00
2	COMP.	19.0	0.250	0.037	0.037	118.00	1.03	0.00
3	INCOMP.	31.0				130.00	0.00	0.00
Total Settlement =							1.03	0.00

N§.	Sublayer		Soil Stresses			Settlement (in.)
	Thick. (ft)	Elev. (ft)	Initial (psf)	Increment (psf)	Max.Past Press. (psf)	
1	INCOMP.					
2	Sublayer over foundation Elev.					
3	Sublayer over foundation Elev.					
4	Sublayer over foundation Elev.					
5	1.10	112.95	2579.28	210.98	2579.28	0.11
6	1.90	111.45	2662.68	210.06	2662.68	0.19
7	1.90	109.55	2768.32	205.06	2768.32	0.18
8	1.90	107.65	2873.96	194.99	2873.96	0.16
9	1.90	105.75	2979.60	181.17	2979.60	0.15
10	1.90	103.85	3085.24	165.63	3085.24	0.13
11	1.90	101.95	3190.88	149.99	3190.88	0.11
12	INCOMP.					
Total Settlement =						1.03 (in.)

RECTANGULAR LOADS

Project Name: North St Culvert, Agawam Project Number : 177018.00
 Client : Woodard-Curran Project Manager: MJO
 Date : 4/6/2023 Computed by : MJO

Increment of stresses obtained using : Boussinesq

Settlement for X = 18.00 (ft) Y = 145.00 (ft)

Footing #	Corner Point P1		Corner Point P2		Load (psf)
	X1(ft)	Y1(ft)	X2(ft)	Y2(ft)	
1	7.00	106.00	29.00	145.00	211.00

Foundation Elev. = 113.50 (ft) Ground Surface Elev.= 136.50 (ft)
 Water table Elev. = 118.00 (ft) Unit weight of Wat. = 62.40 (pcf)

Nº.	Layer Type	Thick. (ft)	Comp. Ratio	Recomp. Ratio	Swell. Ratio	Unit Weight (pcf)	Primary Settlement (in.)	Secondary Settlement (in.)
1	INCOMP.	16.5				125.00	0.00	0.00
2	COMP.	19.0	0.250	0.037	0.037	118.00	0.54	0.00
3	INCOMP.	31.0				130.00	0.00	0.00
Total Settlement =							0.54	0.00

N§.	Sublayer		Soil Stresses			Settlement (in.)
	Thick. (ft)	Elev. (ft)	Initial (psf)	Increment (psf)	Max.Past Press. (psf)	
1	INCOMP.					
2	Sublayer over foundation Elev.					
3	Sublayer over foundation Elev.					
4	Sublayer over foundation Elev.					
5	1.10	112.95	2579.28	105.49	2579.28	0.06
6	1.90	111.45	2662.68	105.22	2662.68	0.10
7	1.90	109.55	2768.32	103.69	2768.32	0.09
8	1.90	107.65	2873.96	100.47	2873.96	0.09
9	1.90	105.75	2979.60	95.80	2979.60	0.08
10	1.90	103.85	3085.24	90.24	3085.24	0.07
11	1.90	101.95	3190.88	84.35	3190.88	0.06
12	INCOMP.					
Total Settlement =						0.54 (in.)

RECTANGULAR LOADS

Project Name: North St Culvert, Agawam Project Number : 177018.00
 Client : Woodard-Curran Project Manager: MJO
 Date : 4/6/2023 Computed by : MJO

Increment of stresses obtained using : Boussinesq

Settlement for X = 7.00 (ft) Y = 32.00 (ft)

Footing #	Corner Point P1		Corner Point P2		Load (psf)
	X1(ft)	Y1(ft)	X2(ft)	Y2(ft)	
1	-33.50	131.00	1.50	156.00	242.00

Foundation Elev. = 125.50 (ft) Ground Surface Elev.= 136.50 (ft)
 Water table Elev. = 118.00 (ft) Unit weight of Wat. = 62.40 (pcf)

Nº.	Layer Type	Thick. (ft)	Comp. Ratio	Recomp. Ratio	Swell.	Unit Weight (pcf)	Primary Settlement (in.)	Secondary Settlement (in.)
1	INCOMP.	16.5				125.00	0.00	0.00
2	COMP.	19.0	0.037	0.037	0.037	118.00	0.00	0.00
3	INCOMP.	31.0				130.00	0.00	0.00
Total Settlement =							0.00	0.00

N§.	Sublayer		Soil Stresses			Settlement (in.)
	Thick. (ft)	Elev. (ft)	Initial (psf)	Increment (psf)	Max.Past Press. (psf)	
1	INCOMP.					
2	1.90	119.05	2174.60	0.00	2174.60	0.00
3	1.90	117.15	2345.76	0.00	2345.76	0.00
4	1.90	115.25	2451.40	0.01	2451.40	0.00
5	1.90	113.35	2557.04	0.01	2557.04	0.00
6	1.90	111.45	2662.68	0.01	2662.68	0.00
7	1.90	109.55	2768.32	0.02	2768.32	0.00
8	1.90	107.65	2873.96	0.03	2873.96	0.00
9	1.90	105.75	2979.60	0.04	2979.60	0.00
10	1.90	103.85	3085.24	0.05	3085.24	0.00
11	1.90	101.95	3190.88	0.06	3190.88	0.00
12	INCOMP.					
Total Settlement =						0.00 (in.)

RECTANGULAR LOADS

Project Name: North St Culvert, Agawam Project Number : 177018.00
 Client : Woodard-Curran Project Manager: MJO
 Date : 4/6/2023 Computed by : MJO

Increment of stresses obtained using : Boussinesq

Settlement for X = 7.00 (ft) Y = 39.50 (ft)

Footing #	Corner Point P1		Corner Point P2		Load (psf)
	X1(ft)	Y1(ft)	X2(ft)	Y2(ft)	
1	-33.50	131.00	1.50	156.00	242.00

Foundation Elev. = 125.50 (ft) Ground Surface Elev.= 136.50 (ft)
 Water table Elev. = 118.00 (ft) Unit weight of Wat. = 62.40 (pcf)

Nº.	Layer Type	Thick. (ft)	Comp. Ratio	Recomp. Ratio	Swell.	Unit Weight (pcf)	Primary Settlement (in.)	Secondary Settlement (in.)
1	INCOMP.	16.5				125.00	0.00	0.00
2	COMP.	19.0	0.037	0.037	0.037	118.00	0.00	0.00
3	INCOMP.	31.0				130.00	0.00	0.00
Total Settlement =							0.00	0.00

N§.	Sublayer		Soil Stresses			Settlement (in.)
	Thick. (ft)	Elev. (ft)	Initial (psf)	Increment (psf)	Max.Past Press. (psf)	
1	INCOMP.					
2	1.90	119.05	2174.60	0.00	2174.60	0.00
3	1.90	117.15	2345.76	0.00	2345.76	0.00
4	1.90	115.25	2451.40	0.01	2451.40	0.00
5	1.90	113.35	2557.04	0.01	2557.04	0.00
6	1.90	111.45	2662.68	0.02	2662.68	0.00
7	1.90	109.55	2768.32	0.03	2768.32	0.00
8	1.90	107.65	2873.96	0.04	2873.96	0.00
9	1.90	105.75	2979.60	0.05	2979.60	0.00
10	1.90	103.85	3085.24	0.07	3085.24	0.00
11	1.90	101.95	3190.88	0.09	3190.88	0.00
12	INCOMP.					
Total Settlement =						0.00 (in.)

RECTANGULAR LOADS

Project Name: North St Culvert, Agawam Project Number : 177018.00
 Client : Woodard-Curran Project Manager: MJO
 Date : 4/6/2023 Computed by : MJO

Increment of stresses obtained using : Boussinesq

Settlement for X = 7.00 (ft) Y = 86.50 (ft)

Footing #	Corner Point P1		Corner Point P2		Load (psf)
	X1(ft)	Y1(ft)	X2(ft)	Y2(ft)	
1	-33.50	131.00	1.50	156.00	242.00

Foundation Elev. = 125.50 (ft) Ground Surface Elev.= 136.50 (ft)
 Water table Elev. = 118.00 (ft) Unit weight of Wat. = 62.40 (pcf)

Nº.	Layer Type	Thick. (ft)	Comp. Ratio	Recomp. Ratio	Swell.	Unit Weight (pcf)	Primary Settlement (in.)	Secondary Settlement (in.)
1	INCOMP.	16.5				125.00	0.00	0.00
2	COMP.	19.0	0.037	0.037	0.037	118.00	0.00	0.00
3	INCOMP.	31.0				130.00	0.00	0.00
Total Settlement =							0.00	0.00

N§.	Sublayer		Soil Stresses			Settlement (in.)
	Thick. (ft)	Elev. (ft)	Initial (psf)	Increment (psf)	Max.Past Press. (psf)	
1	INCOMP.					
2	1.90	119.05	2174.60	0.04	2174.60	0.00
3	1.90	117.15	2345.76	0.08	2345.76	0.00
4	1.90	115.25	2451.40	0.14	2451.40	0.00
5	1.90	113.35	2557.04	0.22	2557.04	0.00
6	1.90	111.45	2662.68	0.33	2662.68	0.00
7	1.90	109.55	2768.32	0.46	2768.32	0.00
8	1.90	107.65	2873.96	0.62	2873.96	0.00
9	1.90	105.75	2979.60	0.79	2979.60	0.00
10	1.90	103.85	3085.24	0.99	3085.24	0.00
11	1.90	101.95	3190.88	1.21	3190.88	0.00
12	INCOMP.					
Total Settlement =						0.00 (in.)

RECTANGULAR LOADS

Project Name: North St Culvert, Agawam Project Number : 177018.00
 Client : Woodard-Curran Project Manager: MJO
 Date : 4/6/2023 Computed by : MJO

Increment of stresses obtained using : Boussinesq

Settlement for X = 7.00 (ft) Y = 109.80 (ft)

Footing #	Corner Point P1		Corner Point P2		Load (psf)
	X1(ft)	Y1(ft)	X2(ft)	Y2(ft)	
1	-33.50	131.00	1.50	156.00	242.00

Foundation Elev. = 125.50 (ft) Ground Surface Elev.= 136.50 (ft)
 Water table Elev. = 118.00 (ft) Unit weight of Wat. = 62.40 (pcf)

Nº.	Layer Type	Thick. (ft)	Comp. Ratio	Recomp. Ratio	Swell.	Unit Weight (pcf)	Primary Settlement (in.)	Secondary Settlement (in.)
1	INCOMP.	16.5				125.00	0.00	0.00
2	COMP.	19.0	0.037	0.037	0.037	118.00	0.00	0.00
3	INCOMP.	31.0				130.00	0.00	0.00
Total Settlement =							0.00	0.00

N§.	Sublayer		Soil Stresses			Settlement (in.)
	Thick. (ft)	Elev. (ft)	Initial (psf)	Increment (psf)	Max.Past Press. (psf)	
1	INCOMP.					
2	1.90	119.05	2174.60	0.38	2174.60	0.00
3	1.90	117.15	2345.76	0.78	2345.76	0.00
4	1.90	115.25	2451.40	1.33	2451.40	0.00
5	1.90	113.35	2557.04	2.01	2557.04	0.00
6	1.90	111.45	2662.68	2.81	2662.68	0.00
7	1.90	109.55	2768.32	3.67	2768.32	0.00
8	1.90	107.65	2873.96	4.57	2873.96	0.00
9	1.90	105.75	2979.60	5.48	2979.60	0.00
10	1.90	103.85	3085.24	6.36	3085.24	0.00
11	1.90	101.95	3190.88	7.19	3190.88	0.00
12	INCOMP.					
Total Settlement =						0.00 (in.)

RECTANGULAR LOADS

Project Name: North St Culvert, Agawam Project Number : 177018.00
 Client : Woodard-Curran Project Manager: MJO
 Date : 4/6/2023 Computed by : MJO

Increment of stresses obtained using : Boussinesq

Settlement for X = 7.00 (ft) Y = 124.80 (ft)

Footing #	Corner Point P1		Corner Point P2		Load (psf)
	X1(ft)	Y1(ft)	X2(ft)	Y2(ft)	
1	-33.50	131.00	1.50	156.00	242.00

Foundation Elev. = 125.50 (ft) Ground Surface Elev.= 136.50 (ft)
 Water table Elev. = 118.00 (ft) Unit weight of Wat. = 62.40 (pcf)

Nº.	Layer Type	Thick. (ft)	Comp. Ratio	Recomp. Ratio	Swell.	Unit Weight (pcf)	Primary Settlement (in.)	Secondary Settlement (in.)
1	INCOMP.	16.5				125.00	0.00	0.00
2	COMP.	19.0	0.037	0.037	0.037	118.00	0.02	0.00
3	INCOMP.	31.0				130.00	0.00	0.00
Total Settlement =							0.02	0.00

N§.	Sublayer		Soil Stresses			Settlement (in.)
	Thick. (ft)	Elev. (ft)	Initial (psf)	Increment (psf)	Max.Past Press. (psf)	
1	INCOMP.					
2	1.90	119.05	2174.60	4.60	2174.60	0.00
3	1.90	117.15	2345.76	7.68	2345.76	0.00
4	1.90	115.25	2451.40	10.82	2451.40	0.00
5	1.90	113.35	2557.04	13.73	2557.04	0.00
6	1.90	111.45	2662.68	16.28	2662.68	0.00
7	1.90	109.55	2768.32	18.41	2768.32	0.00
8	1.90	107.65	2873.96	20.13	2873.96	0.00
9	1.90	105.75	2979.60	21.47	2979.60	0.00
10	1.90	103.85	3085.24	22.46	3085.24	0.00
11	1.90	101.95	3190.88	23.15	3190.88	0.00
12	INCOMP.					
Total Settlement =						0.02 (in.)

RECTANGULAR LOADS

Project Name: North St Culvert, Agawam Project Number : 177018.00
 Client : Woodard-Curran Project Manager: MJO
 Date : 4/6/2023 Computed by : MJO

Increment of stresses obtained using : Boussinesq

Settlement for X = 7.00 (ft) Y = 138.00 (ft)

Footing #	Corner Point P1		Corner Point P2		Load (psf)
	X1(ft)	Y1(ft)	X2(ft)	Y2(ft)	
1	-33.50	131.00	1.50	156.00	242.00

Foundation Elev. = 125.50 (ft) Ground Surface Elev.= 136.50 (ft)
 Water table Elev. = 118.00 (ft) Unit weight of Wat. = 62.40 (pcf)

Nº.	Layer Type	Thick. (ft)	Comp. Ratio	Recomp. Ratio	Swell. Ratio	Unit Weight (pcf)	Primary Settlement (in.)	Secondary Settlement (in.)
1	INCOMP.	16.5				125.00	0.00	0.00
2	COMP.	19.0	0.037	0.037	0.037	118.00	0.05	0.00
3	INCOMP.	31.0				130.00	0.00	0.00
Total Settlement =							0.05	0.00

N§.	Sublayer		Soil Stresses			Settlement (in.)
	Thick. (ft)	Elev. (ft)	Initial (psf)	Increment (psf)	Max.Past Press. (psf)	
1	INCOMP.					
2	1.90	119.05	2174.60	23.67	2174.60	0.00
3	1.90	117.15	2345.76	32.05	2345.76	0.00
4	1.90	115.25	2451.40	37.92	2451.40	0.01
5	1.90	113.35	2557.04	41.65	2557.04	0.01
6	1.90	111.45	2662.68	43.76	2662.68	0.01
7	1.90	109.55	2768.32	44.70	2768.32	0.01
8	1.90	107.65	2873.96	44.81	2873.96	0.01
9	1.90	105.75	2979.60	44.35	2979.60	0.01
10	1.90	103.85	3085.24	43.48	3085.24	0.01
11	1.90	101.95	3190.88	42.35	3190.88	0.00
12	INCOMP.					
Total Settlement =						0.05 (in.)

RECTANGULAR LOADS

Project Name: North St Culvert, Agawam Project Number : 177018.00
 Client : Woodard-Curran Project Manager: MJO
 Date : 4/6/2023 Computed by : MJO

Increment of stresses obtained using : Boussinesq

Settlement for X = 18.00 (ft) Y = 37.00 (ft)

Footing #	Corner Point P1		Corner Point P2		Load (psf)
	X1(ft)	Y1(ft)	X2(ft)	Y2(ft)	
1	-33.50	131.00	1.50	156.00	242.00

Foundation Elev. = 125.50 (ft) Ground Surface Elev.= 136.50 (ft)
 Water table Elev. = 118.00 (ft) Unit weight of Wat. = 62.40 (pcf)

Nº.	Layer Type	Thick. (ft)	Comp. Ratio	Recomp. Ratio	Swell.	Unit Weight (pcf)	Primary Settlement (in.)	Secondary Settlement (in.)
1	INCOMP.	16.5				125.00	0.00	0.00
2	COMP.	19.0	0.037	0.037	0.037	118.00	0.00	0.00
3	INCOMP.	31.0				130.00	0.00	0.00
Total Settlement =							0.00	0.00

N§.	Sublayer		Soil Stresses			Settlement (in.)
	Thick. (ft)	Elev. (ft)	Initial (psf)	Increment (psf)	Max.Past Press. (psf)	
1	INCOMP.					
2	1.90	119.05	2174.60	0.00	2174.60	0.00
3	1.90	117.15	2345.76	0.00	2345.76	0.00
4	1.90	115.25	2451.40	0.01	2451.40	0.00
5	1.90	113.35	2557.04	0.01	2557.04	0.00
6	1.90	111.45	2662.68	0.02	2662.68	0.00
7	1.90	109.55	2768.32	0.02	2768.32	0.00
8	1.90	107.65	2873.96	0.03	2873.96	0.00
9	1.90	105.75	2979.60	0.04	2979.60	0.00
10	1.90	103.85	3085.24	0.06	3085.24	0.00
11	1.90	101.95	3190.88	0.07	3190.88	0.00
12	INCOMP.					
Total Settlement =						0.00 (in.)

RECTANGULAR LOADS

Project Name: North St Culvert, Agawam Project Number : 177018.00
 Client : Woodard-Curran Project Manager: MJO
 Date : 4/6/2023 Computed by : MJO

Increment of stresses obtained using : Boussinesq

Settlement for X = 18.00 (ft) Y = 47.50 (ft)

Footing #	Corner Point P1		Corner Point P2		Load (psf)
	X1(ft)	Y1(ft)	X2(ft)	Y2(ft)	
1	-33.50	131.00	1.50	156.00	242.00

Foundation Elev. = 125.50 (ft) Ground Surface Elev.= 136.50 (ft)
 Water table Elev. = 118.00 (ft) Unit weight of Wat. = 62.40 (pcf)

Nº.	Layer Type	Thick. (ft)	Comp. Ratio	Recomp. Ratio	Swell.	Unit Weight (pcf)	Primary Settlement (in.)	Secondary Settlement (in.)
1	INCOMP.	16.5				125.00	0.00	0.00
2	COMP.	19.0	0.037	0.037	0.037	118.00	0.00	0.00
3	INCOMP.	31.0				130.00	0.00	0.00
Total Settlement =							0.00	0.00

N§.	Sublayer		Soil Stresses			Settlement (in.)
	Thick. (ft)	Elev. (ft)	Initial (psf)	Increment (psf)	Max.Past Press. (psf)	
1	INCOMP.					
2	1.90	119.05	2174.60	0.00	2174.60	0.00
3	1.90	117.15	2345.76	0.01	2345.76	0.00
4	1.90	115.25	2451.40	0.01	2451.40	0.00
5	1.90	113.35	2557.04	0.02	2557.04	0.00
6	1.90	111.45	2662.68	0.03	2662.68	0.00
7	1.90	109.55	2768.32	0.04	2768.32	0.00
8	1.90	107.65	2873.96	0.05	2873.96	0.00
9	1.90	105.75	2979.60	0.07	2979.60	0.00
10	1.90	103.85	3085.24	0.09	3085.24	0.00
11	1.90	101.95	3190.88	0.11	3190.88	0.00
12	INCOMP.					
Total Settlement =						0.00 (in.)

RECTANGULAR LOADS

Project Name: North St Culvert, Agawam Project Number : 177018.00
 Client : Woodard-Curran Project Manager: MJO
 Date : 4/6/2023 Computed by : MJO

Increment of stresses obtained using : Boussinesq

Settlement for X = 18.00 (ft) Y = 86.50 (ft)

Footing #	Corner Point P1		Corner Point P2		Load (psf)
	X1(ft)	Y1(ft)	X2(ft)	Y2(ft)	
1	-33.50	131.00	1.50	156.00	242.00

Foundation Elev. = 125.50 (ft) Ground Surface Elev.= 136.50 (ft)
 Water table Elev. = 118.00 (ft) Unit weight of Wat. = 62.40 (pcf)

Nº.	Layer Type	Thick. (ft)	Comp. Ratio	Recomp. Ratio	Swell.	Unit Weight (pcf)	Primary Settlement (in.)	Secondary Settlement (in.)
1	INCOMP.	16.5				125.00	0.00	0.00
2	COMP.	19.0	0.037	0.037	0.037	118.00	0.00	0.00
3	INCOMP.	31.0				130.00	0.00	0.00
Total Settlement =							0.00	0.00

N§.	Sublayer		Soil Stresses			Settlement (in.)
	Thick. (ft)	Elev. (ft)	Initial (psf)	Increment (psf)	Max.Past Press. (psf)	
1	INCOMP.					
2	1.90	119.05	2174.60	0.02	2174.60	0.00
3	1.90	117.15	2345.76	0.05	2345.76	0.00
4	1.90	115.25	2451.40	0.09	2451.40	0.00
5	1.90	113.35	2557.04	0.15	2557.04	0.00
6	1.90	111.45	2662.68	0.23	2662.68	0.00
7	1.90	109.55	2768.32	0.32	2768.32	0.00
8	1.90	107.65	2873.96	0.44	2873.96	0.00
9	1.90	105.75	2979.60	0.57	2979.60	0.00
10	1.90	103.85	3085.24	0.71	3085.24	0.00
11	1.90	101.95	3190.88	0.87	3190.88	0.00
12	INCOMP.					
Total Settlement =						0.00 (in.)

RECTANGULAR LOADS

Project Name: North St Culvert, Agawam Project Number : 177018.00
 Client : Woodard-Curran Project Manager: MJO
 Date : 4/6/2023 Computed by : MJO

Increment of stresses obtained using : Boussinesq

Settlement for X = 18.00 (ft) Y = 125.50 (ft)

Footing #	Corner Point P1		Corner Point P2		Load (psf)
	X1(ft)	Y1(ft)	X2(ft)	Y2(ft)	
1	-33.50	131.00	1.50	156.00	242.00

Foundation Elev. = 125.50 (ft) Ground Surface Elev.= 136.50 (ft)
 Water table Elev. = 118.00 (ft) Unit weight of Wat. = 62.40 (pcf)

Nº.	Layer Type	Thick. (ft)	Comp. Ratio	Recomp. Ratio	Swell.	Unit Weight (pcf)	Primary Settlement (in.)	Secondary Settlement (in.)
1	INCOMP.	16.5				125.00	0.00	0.00
2	COMP.	19.0	0.037	0.037	0.037	118.00	0.01	0.00
3	INCOMP.	31.0				130.00	0.00	0.00
Total Settlement =							0.01	0.00

N§.	Sublayer		Soil Stresses			Settlement (in.)
	Thick. (ft)	Elev. (ft)	Initial (psf)	Increment (psf)	Max.Past Press. (psf)	
1	INCOMP.					
2	1.90	119.05	2174.60	0.73	2174.60	0.00
3	1.90	117.15	2345.76	1.43	2345.76	0.00
4	1.90	115.25	2451.40	2.36	2451.40	0.00
5	1.90	113.35	2557.04	3.46	2557.04	0.00
6	1.90	111.45	2662.68	4.65	2662.68	0.00
7	1.90	109.55	2768.32	5.88	2768.32	0.00
8	1.90	107.65	2873.96	7.08	2873.96	0.00
9	1.90	105.75	2979.60	8.22	2979.60	0.00
10	1.90	103.85	3085.24	9.27	3085.24	0.00
11	1.90	101.95	3190.88	10.21	3190.88	0.00
12	INCOMP.					
Total Settlement =						0.01 (in.)

RECTANGULAR LOADS

Project Name: North St Culvert, Agawam Project Number : 177018.00
 Client : Woodard-Curran Project Manager: MJO
 Date : 4/6/2023 Computed by : MJO

Increment of stresses obtained using : Boussinesq

Settlement for X = 18.00 (ft) Y = 135.80 (ft)

Footing #	Corner Point P1		Corner Point P2		Load (psf)
	X1(ft)	Y1(ft)	X2(ft)	Y2(ft)	
1	-33.50	131.00	1.50	156.00	242.00

Foundation Elev. = 125.50 (ft) Ground Surface Elev.= 136.50 (ft)
 Water table Elev. = 118.00 (ft) Unit weight of Wat. = 62.40 (pcf)

Nº.	Layer Type	Thick. (ft)	Comp. Ratio	Recomp. Ratio	Swell.	Unit Weight (pcf)	Primary Settlement (in.)	Secondary Settlement (in.)	
1	INCOMP.	16.5				125.00	0.00	0.00	
2	COMP.	19.0	0.037	0.037	0.037	118.00	0.01	0.00	
3	INCOMP.	31.0				130.00	0.00	0.00	
Total Settlement =								0.01	0.00

N§.	Sublayer		Soil Stresses			Settlement (in.)
	Thick. (ft)	Elev. (ft)	Initial (psf)	Increment (psf)	Max.Past Press. (psf)	
1	INCOMP.					
2	1.90	119.05	2174.60	1.41	2174.60	0.00
3	1.90	117.15	2345.76	2.69	2345.76	0.00
4	1.90	115.25	2451.40	4.29	2451.40	0.00
5	1.90	113.35	2557.04	6.07	2557.04	0.00
6	1.90	111.45	2662.68	7.90	2662.68	0.00
7	1.90	109.55	2768.32	9.66	2768.32	0.00
8	1.90	107.65	2873.96	11.28	2873.96	0.00
9	1.90	105.75	2979.60	12.71	2979.60	0.00
10	1.90	103.85	3085.24	13.93	3085.24	0.00
11	1.90	101.95	3190.88	14.94	3190.88	0.00
12	INCOMP.					
Total Settlement =						0.01 (in.)

RECTANGULAR LOADS

Project Name: North St Culvert, Agawam Project Number : 177018.00
 Client : Woodard-Curran Project Manager: MJO
 Date : 4/6/2023 Computed by : MJO

Increment of stresses obtained using : Boussinesq

Settlement for X = 18.00 (ft) Y = 145.00 (ft)

Footing #	Corner Point P1		Corner Point P2		Load (psf)
	X1(ft)	Y1(ft)	X2(ft)	Y2(ft)	
1	-33.50	131.00	1.50	156.00	242.00

Foundation Elev. = 125.50 (ft) Ground Surface Elev.= 136.50 (ft)
 Water table Elev. = 118.00 (ft) Unit weight of Wat. = 62.40 (pcf)

Nº.	Layer Type	Thick. (ft)	Comp. Ratio	Recomp. Ratio	Swell.	Unit Weight (pcf)	Primary Settlement (in.)	Secondary Settlement (in.)
1	INCOMP.	16.5				125.00	0.00	0.00
2	COMP.	19.0	0.037	0.037	0.037	118.00	0.01	0.00
3	INCOMP.	31.0				130.00	0.00	0.00
Total Settlement =							0.01	0.00

N§.	Sublayer		Soil Stresses			Settlement (in.)
	Thick. (ft)	Elev. (ft)	Initial (psf)	Increment (psf)	Max.Past Press. (psf)	
1	INCOMP.					
2	1.90	119.05	2174.60	1.61	2174.60	0.00
3	1.90	117.15	2345.76	3.07	2345.76	0.00
4	1.90	115.25	2451.40	4.87	2451.40	0.00
5	1.90	113.35	2557.04	6.86	2557.04	0.00
6	1.90	111.45	2662.68	8.87	2662.68	0.00
7	1.90	109.55	2768.32	10.79	2768.32	0.00
8	1.90	107.65	2873.96	12.52	2873.96	0.00
9	1.90	105.75	2979.60	14.02	2979.60	0.00
10	1.90	103.85	3085.24	15.27	3085.24	0.00
11	1.90	101.95	3190.88	16.28	3190.88	0.00
12	INCOMP.					
Total Settlement =						0.01 (in.)

RECTANGULAR LOADS

Project Name: North St Culvert, Agawam Project Number : 177018.00
 Client : Woodard-Curran Project Manager: MJO
 Date : 4/6/2023 Computed by : MJO

Increment of stresses obtained using : Boussinesq

Settlement for X = 7.00 (ft) Y = 32.00 (ft)

Footing #	Corner Point P1		Corner Point P2		Load (psf)
	X1(ft)	Y1(ft)	X2(ft)	Y2(ft)	
1	1.50	131.00	7.00	145.00	483.00

Foundation Elev. = 119.00 (ft) Ground Surface Elev.= 136.50 (ft)
 Water table Elev. = 118.00 (ft) Unit weight of Wat. = 62.40 (pcf)

Nº.	Layer Type	Thick. (ft)	Comp. Ratio	Recomp. Ratio	Swell.	Unit Weight (pcf)	Primary Settlement (in.)	Secondary Settlement (in.)
1	INCOMP.	16.5				125.00	0.00	0.00
2	COMP.	19.0	0.037	0.037	0.037	118.00	0.00	0.00
3	INCOMP.	31.0				130.00	0.00	0.00
Total Settlement =							0.00	0.00

N§.	Sublayer		Soil Stresses			Settlement (in.)
	Thick. (ft)	Elev. (ft)	Initial (psf)	Increment (psf)	Max.Past Press. (psf)	
1	INCOMP.					
2	0.90	118.55	2233.60	0.00	2233.60	0.00
3	1.90	117.15	2345.76	0.00	2345.76	0.00
4	1.90	115.25	2451.40	0.00	2451.40	0.00
5	1.90	113.35	2557.04	0.00	2557.04	0.00
6	1.90	111.45	2662.68	0.00	2662.68	0.00
7	1.90	109.55	2768.32	0.00	2768.32	0.00
8	1.90	107.65	2873.96	0.00	2873.96	0.00
9	1.90	105.75	2979.60	0.00	2979.60	0.00
10	1.90	103.85	3085.24	0.00	3085.24	0.00
11	1.90	101.95	3190.88	0.01	3190.88	0.00
12	INCOMP.					
Total Settlement =						0.00 (in.)

RECTANGULAR LOADS

Project Name: North St Culvert, Agawam Project Number : 177018.00
 Client : Woodard-Curran Project Manager: MJO
 Date : 4/6/2023 Computed by : MJO

Increment of stresses obtained using : Boussinesq

Settlement for X = 7.00 (ft) Y = 39.50 (ft)

Footing #	Corner Point P1		Corner Point P2		Load (psf)
	X1(ft)	Y1(ft)	X2(ft)	Y2(ft)	
1	1.50	131.00	7.00	145.00	483.00

Foundation Elev. = 119.00 (ft) Ground Surface Elev.= 136.50 (ft)
 Water table Elev. = 118.00 (ft) Unit weight of Wat. = 62.40 (pcf)

Nº.	Layer Type	Thick. (ft)	Comp. Ratio	Recomp. Ratio	Swell.	Unit Weight (pcf)	Primary Settlement (in.)	Secondary Settlement (in.)
1	INCOMP.	16.5				125.00	0.00	0.00
2	COMP.	19.0	0.037	0.037	0.037	118.00	0.00	0.00
3	INCOMP.	31.0				130.00	0.00	0.00
Total Settlement =							0.00	0.00

N§.	Sublayer		Soil Stresses			Settlement (in.)
	Thick. (ft)	Elev. (ft)	Initial (psf)	Increment (psf)	Max.Past Press. (psf)	
1	INCOMP.					
2	0.90	118.55	2233.60	0.00	2233.60	0.00
3	1.90	117.15	2345.76	0.00	2345.76	0.00
4	1.90	115.25	2451.40	0.00	2451.40	0.00
5	1.90	113.35	2557.04	0.00	2557.04	0.00
6	1.90	111.45	2662.68	0.00	2662.68	0.00
7	1.90	109.55	2768.32	0.00	2768.32	0.00
8	1.90	107.65	2873.96	0.00	2873.96	0.00
9	1.90	105.75	2979.60	0.00	2979.60	0.00
10	1.90	103.85	3085.24	0.01	3085.24	0.00
11	1.90	101.95	3190.88	0.01	3190.88	0.00
12	INCOMP.					
Total Settlement =						0.00 (in.)

RECTANGULAR LOADS

Project Name: North St Culvert, Agawam Project Number : 177018.00
 Client : Woodard-Curran Project Manager: MJO
 Date : 4/6/2023 Computed by : MJO

Increment of stresses obtained using : Boussinesq

Settlement for X = 7.00 (ft) Y = 86.50 (ft)

Footing #	Corner Point P1		Corner Point P2		Load (psf)
	X1(ft)	Y1(ft)	X2(ft)	Y2(ft)	
1	1.50	131.00	7.00	145.00	483.00

Foundation Elev. = 119.00 (ft) Ground Surface Elev.= 136.50 (ft)
 Water table Elev. = 118.00 (ft) Unit weight of Wat. = 62.40 (pcf)

Nº.	Layer Type	Thick. (ft)	Comp. Ratio	Recomp. Ratio	Swell.	Unit Weight (pcf)	Primary Settlement (in.)	Secondary Settlement (in.)
1	INCOMP.	16.5				125.00	0.00	0.00
2	COMP.	19.0	0.037	0.037	0.037	118.00	0.00	0.00
3	INCOMP.	31.0				130.00	0.00	0.00
Total Settlement =							0.00	0.00

N§.	Sublayer		Soil Stresses			Settlement (in.)
	Thick. (ft)	Elev. (ft)	Initial (psf)	Increment (psf)	Max.Past Press. (psf)	
1	INCOMP.					
2	0.90	118.55	2233.60	0.00	2233.60	0.00
3	1.90	117.15	2345.76	0.00	2345.76	0.00
4	1.90	115.25	2451.40	0.00	2451.40	0.00
5	1.90	113.35	2557.04	0.01	2557.04	0.00
6	1.90	111.45	2662.68	0.02	2662.68	0.00
7	1.90	109.55	2768.32	0.04	2768.32	0.00
8	1.90	107.65	2873.96	0.07	2873.96	0.00
9	1.90	105.75	2979.60	0.10	2979.60	0.00
10	1.90	103.85	3085.24	0.15	3085.24	0.00
11	1.90	101.95	3190.88	0.20	3190.88	0.00
12	INCOMP.					
Total Settlement =						0.00 (in.)

RECTANGULAR LOADS

Project Name: North St Culvert, Agawam Project Number : 177018.00
 Client : Woodard-Curran Project Manager: MJO
 Date : 4/6/2023 Computed by : MJO

Increment of stresses obtained using : Boussinesq

Settlement for X = 7.00 (ft) Y = 109.80 (ft)

Footing #	Corner Point P1		Corner Point P2		Load (psf)
	X1(ft)	Y1(ft)	X2(ft)	Y2(ft)	
1	1.50	131.00	7.00	145.00	483.00

Foundation Elev. = 119.00 (ft) Ground Surface Elev.= 136.50 (ft)
 Water table Elev. = 118.00 (ft) Unit weight of Wat. = 62.40 (pcf)

Nº.	Layer Type	Thick. (ft)	Comp. Ratio	Recomp. Ratio	Swell.	Unit Weight (pcf)	Primary Settlement (in.)	Secondary Settlement (in.)
1	INCOMP.	16.5				125.00	0.00	0.00
2	COMP.	19.0	0.037	0.037	0.037	118.00	0.00	0.00
3	INCOMP.	31.0				130.00	0.00	0.00
Total Settlement =							0.00	0.00

N§.	Sublayer		Soil Stresses			Settlement (in.)
	Thick. (ft)	Elev. (ft)	Initial (psf)	Increment (psf)	Max.Past Press. (psf)	
1	INCOMP.					
2	0.90	118.55	2233.60	0.00	2233.60	0.00
3	1.90	117.15	2345.76	0.01	2345.76	0.00
4	1.90	115.25	2451.40	0.07	2451.40	0.00
5	1.90	113.35	2557.04	0.21	2557.04	0.00
6	1.90	111.45	2662.68	0.45	2662.68	0.00
7	1.90	109.55	2768.32	0.80	2768.32	0.00
8	1.90	107.65	2873.96	1.21	2873.96	0.00
9	1.90	105.75	2979.60	1.66	2979.60	0.00
10	1.90	103.85	3085.24	2.13	3085.24	0.00
11	1.90	101.95	3190.88	2.57	3190.88	0.00
12	INCOMP.					
Total Settlement =						0.00 (in.)

RECTANGULAR LOADS

Project Name: North St Culvert, Agawam Project Number : 177018.00
 Client : Woodard-Curran Project Manager: MJO
 Date : 4/6/2023 Computed by : MJO

Increment of stresses obtained using : Boussinesq

Settlement for X = 7.00 (ft) Y = 124.80 (ft)

Footing #	Corner Point P1		Corner Point P2		Load (psf)
	X1(ft)	Y1(ft)	X2(ft)	Y2(ft)	
1	1.50	131.00	7.00	145.00	483.00

Foundation Elev. = 119.00 (ft) Ground Surface Elev.= 136.50 (ft)
 Water table Elev. = 118.00 (ft) Unit weight of Wat. = 62.40 (pcf)

Nº.	Layer Type	Thick. (ft)	Comp. Ratio	Recomp. Ratio	Swell.	Unit Weight (pcf)	Primary Settlement (in.)	Secondary Settlement (in.)
1	INCOMP.	16.5				125.00	0.00	0.00
2	COMP.	19.0	0.037	0.037	0.037	118.00	0.02	0.00
3	INCOMP.	31.0				130.00	0.00	0.00
Total Settlement =							0.02	0.00

N§.	Sublayer		Soil Stresses			Settlement (in.)
	Thick. (ft)	Elev. (ft)	Initial (psf)	Increment (psf)	Max.Past Press. (psf)	
1	INCOMP.					
2	0.90	118.55	2233.60	0.01	2233.60	0.00
3	1.90	117.15	2345.76	0.86	2345.76	0.00
4	1.90	115.25	2451.40	5.11	2451.40	0.00
5	1.90	113.35	2557.04	11.10	2557.04	0.00
6	1.90	111.45	2662.68	16.18	2662.68	0.00
7	1.90	109.55	2768.32	19.42	2768.32	0.00
8	1.90	107.65	2873.96	20.99	2873.96	0.00
9	1.90	105.75	2979.60	21.37	2979.60	0.00
10	1.90	103.85	3085.24	20.98	3085.24	0.00
11	1.90	101.95	3190.88	20.14	3190.88	0.00
12	INCOMP.					
Total Settlement =						0.02 (in.)

RECTANGULAR LOADS

Project Name: North St Culvert, Agawam Project Number : 177018.00
 Client : Woodard-Curran Project Manager: MJO
 Date : 4/6/2023 Computed by : MJO

Increment of stresses obtained using : Boussinesq

Settlement for X = 7.00 (ft) Y = 138.00 (ft)

Footing #	Corner Point P1		Corner Point P2		Load (psf)
	X1(ft)	Y1(ft)	X2(ft)	Y2(ft)	
1	1.50	131.00	7.00	145.00	483.00

Foundation Elev. = 119.00 (ft) Ground Surface Elev.= 136.50 (ft)
 Water table Elev. = 118.00 (ft) Unit weight of Wat. = 62.40 (pcf)

Nº.	Layer Type	Thick. (ft)	Comp. Ratio	Recomp. Ratio	Swell.	Unit Weight (pcf)	Primary Settlement (in.)	Secondary Settlement (in.)
1	INCOMP.	16.5				125.00	0.00	0.00
2	COMP.	19.0	0.037	0.037	0.037	118.00	0.18	0.00
3	INCOMP.	31.0				130.00	0.00	0.00
Total Settlement =							0.18	0.00

N§.	Sublayer		Soil Stresses			Settlement (in.)
	Thick. (ft)	Elev. (ft)	Initial (psf)	Increment (psf)	Max.Past Press. (psf)	
1	INCOMP.					
2	0.90	118.55	2233.60	241.43	2233.60	0.02
3	1.90	117.15	2345.76	236.91	2345.76	0.04
4	1.90	115.25	2451.40	213.72	2451.40	0.03
5	1.90	113.35	2557.04	178.42	2557.04	0.02
6	1.90	111.45	2662.68	143.32	2662.68	0.02
7	1.90	109.55	2768.32	113.94	2768.32	0.01
8	1.90	107.65	2873.96	90.98	2873.96	0.01
9	1.90	105.75	2979.60	73.43	2979.60	0.01
10	1.90	103.85	3085.24	60.05	3085.24	0.01
11	1.90	101.95	3190.88	49.76	3190.88	0.01
12	INCOMP.					
Total Settlement =						0.18 (in.)

RECTANGULAR LOADS

Project Name: North St Culvert, Agawam Project Number : 177018.00
 Client : Woodard-Curran Project Manager: MJO
 Date : 4/6/2023 Computed by : MJO

Increment of stresses obtained using : Boussinesq

Settlement for X = 18.00 (ft) Y = 37.00 (ft)

Footing #	Corner Point P1		Corner Point P2		Load (psf)
	X1(ft)	Y1(ft)	X2(ft)	Y2(ft)	
1	1.50	131.00	7.00	145.00	483.00

Foundation Elev. = 119.00 (ft) Ground Surface Elev.= 136.50 (ft)
 Water table Elev. = 118.00 (ft) Unit weight of Wat. = 62.40 (pcf)

Nº.	Layer Type	Thick. (ft)	Comp. Ratio	Recomp. Ratio	Swell.	Unit Weight (pcf)	Primary Settlement (in.)	Secondary Settlement (in.)
1	INCOMP.	16.5				125.00	0.00	0.00
2	COMP.	19.0	0.037	0.037	0.037	118.00	0.00	0.00
3	INCOMP.	31.0				130.00	0.00	0.00
Total Settlement =							0.00	0.00

N§.	Sublayer		Soil Stresses			Settlement (in.)
	Thick. (ft)	Elev. (ft)	Initial (psf)	Increment (psf)	Max.Past Press. (psf)	
1	INCOMP.					
2	0.90	118.55	2233.60	0.00	2233.60	0.00
3	1.90	117.15	2345.76	0.00	2345.76	0.00
4	1.90	115.25	2451.40	0.00	2451.40	0.00
5	1.90	113.35	2557.04	0.00	2557.04	0.00
6	1.90	111.45	2662.68	0.00	2662.68	0.00
7	1.90	109.55	2768.32	0.00	2768.32	0.00
8	1.90	107.65	2873.96	0.00	2873.96	0.00
9	1.90	105.75	2979.60	0.00	2979.60	0.00
10	1.90	103.85	3085.24	0.01	3085.24	0.00
11	1.90	101.95	3190.88	0.01	3190.88	0.00
12	INCOMP.					
Total Settlement =						0.00 (in.)

RECTANGULAR LOADS

Project Name: North St Culvert, Agawam Project Number : 177018.00
 Client : Woodard-Curran Project Manager: MJO
 Date : 4/6/2023 Computed by : MJO

Increment of stresses obtained using : Boussinesq

Settlement for X = 18.00 (ft) Y = 47.50 (ft)

Footing #	Corner Point P1		Corner Point P2		Load (psf)
	X1(ft)	Y1(ft)	X2(ft)	Y2(ft)	
1	1.50	131.00	7.00	145.00	483.00

Foundation Elev. = 119.00 (ft) Ground Surface Elev.= 136.50 (ft)
 Water table Elev. = 118.00 (ft) Unit weight of Wat. = 62.40 (pcf)

Nº.	Layer Type	Thick. (ft)	Comp. Ratio	Recomp. Ratio	Swell.	Unit Weight (pcf)	Primary Settlement (in.)	Secondary Settlement (in.)
1	INCOMP.	16.5				125.00	0.00	0.00
2	COMP.	19.0	0.037	0.037	0.037	118.00	0.00	0.00
3	INCOMP.	31.0				130.00	0.00	0.00
Total Settlement =							0.00	0.00

N§.	Sublayer		Soil Stresses			Settlement (in.)
	Thick. (ft)	Elev. (ft)	Initial (psf)	Increment (psf)	Max.Past Press. (psf)	
1	INCOMP.					
2	0.90	118.55	2233.60	0.00	2233.60	0.00
3	1.90	117.15	2345.76	0.00	2345.76	0.00
4	1.90	115.25	2451.40	0.00	2451.40	0.00
5	1.90	113.35	2557.04	0.00	2557.04	0.00
6	1.90	111.45	2662.68	0.00	2662.68	0.00
7	1.90	109.55	2768.32	0.00	2768.32	0.00
8	1.90	107.65	2873.96	0.00	2873.96	0.00
9	1.90	105.75	2979.60	0.01	2979.60	0.00
10	1.90	103.85	3085.24	0.01	3085.24	0.00
11	1.90	101.95	3190.88	0.01	3190.88	0.00
12	INCOMP.					
Total Settlement =						0.00 (in.)

RECTANGULAR LOADS

Project Name: North St Culvert, Agawam Project Number : 177018.00
 Client : Woodard-Curran Project Manager: MJO
 Date : 4/6/2023 Computed by : MJO

Increment of stresses obtained using : Boussinesq

Settlement for X = 18.00 (ft) Y = 86.50 (ft)

Footing #	Corner Point P1		Corner Point P2		Load (psf)
	X1(ft)	Y1(ft)	X2(ft)	Y2(ft)	
1	1.50	131.00	7.00	145.00	483.00

Foundation Elev. = 119.00 (ft) Ground Surface Elev.= 136.50 (ft)
 Water table Elev. = 118.00 (ft) Unit weight of Wat. = 62.40 (pcf)

Nº.	Layer Type	Thick. (ft)	Comp. Ratio	Recomp. Ratio	Swell.	Unit Weight (pcf)	Primary Settlement (in.)	Secondary Settlement (in.)
1	INCOMP.	16.5				125.00	0.00	0.00
2	COMP.	19.0	0.037	0.037	0.037	118.00	0.00	0.00
3	INCOMP.	31.0				130.00	0.00	0.00
Total Settlement =							0.00	0.00

N§.	Sublayer		Soil Stresses			Settlement (in.)
	Thick. (ft)	Elev. (ft)	Initial (psf)	Increment (psf)	Max.Past Press. (psf)	
1	INCOMP.					
2	0.90	118.55	2233.60	0.00	2233.60	0.00
3	1.90	117.15	2345.76	0.00	2345.76	0.00
4	1.90	115.25	2451.40	0.00	2451.40	0.00
5	1.90	113.35	2557.04	0.01	2557.04	0.00
6	1.90	111.45	2662.68	0.02	2662.68	0.00
7	1.90	109.55	2768.32	0.03	2768.32	0.00
8	1.90	107.65	2873.96	0.06	2873.96	0.00
9	1.90	105.75	2979.60	0.09	2979.60	0.00
10	1.90	103.85	3085.24	0.13	3085.24	0.00
11	1.90	101.95	3190.88	0.17	3190.88	0.00
12	INCOMP.					
Total Settlement =						0.00 (in.)

RECTANGULAR LOADS

Project Name: North St Culvert, Agawam Project Number : 177018.00
 Client : Woodard-Curran Project Manager: MJO
 Date : 4/6/2023 Computed by : MJO

Increment of stresses obtained using : Boussinesq

Settlement for X = 18.00 (ft) Y = 125.50 (ft)

Footing #	Corner Point P1		Corner Point P2		Load (psf)
	X1(ft)	Y1(ft)	X2(ft)	Y2(ft)	
1	1.50	131.00	7.00	145.00	483.00

Foundation Elev. = 119.00 (ft) Ground Surface Elev.= 136.50 (ft)
 Water table Elev. = 118.00 (ft) Unit weight of Wat. = 62.40 (pcf)

Nº.	Layer Type	Thick. (ft)	Comp. Ratio	Recomp. Ratio	Swell.	Unit Weight (pcf)	Primary Settlement (in.)	Secondary Settlement (in.)
1	INCOMP.	16.5				125.00	0.00	0.00
2	COMP.	19.0	0.037	0.037	0.037	118.00	0.00	0.00
3	INCOMP.	31.0				130.00	0.00	0.00
Total Settlement =							0.00	0.00

N§.	Sublayer		Soil Stresses			Settlement (in.)
	Thick. (ft)	Elev. (ft)	Initial (psf)	Increment (psf)	Max.Past Press. (psf)	
1	INCOMP.					
2	0.90	118.55	2233.60	0.00	2233.60	0.00
3	1.90	117.15	2345.76	0.07	2345.76	0.00
4	1.90	115.25	2451.40	0.50	2451.40	0.00
5	1.90	113.35	2557.04	1.47	2557.04	0.00
6	1.90	111.45	2662.68	2.88	2662.68	0.00
7	1.90	109.55	2768.32	4.47	2768.32	0.00
8	1.90	107.65	2873.96	6.02	2873.96	0.00
9	1.90	105.75	2979.60	7.34	2979.60	0.00
10	1.90	103.85	3085.24	8.37	3085.24	0.00
11	1.90	101.95	3190.88	9.08	3190.88	0.00
12	INCOMP.					
Total Settlement =						0.00 (in.)

RECTANGULAR LOADS

Project Name: North St Culvert, Agawam Project Number : 177018.00
 Client : Woodard-Curran Project Manager: MJO
 Date : 4/6/2023 Computed by : MJO

Increment of stresses obtained using : Boussinesq

Settlement for X = 18.00 (ft) Y = 135.80 (ft)

Footing #	Corner Point P1		Corner Point P2		Load (psf)
	X1(ft)	Y1(ft)	X2(ft)	Y2(ft)	
1	1.50	131.00	7.00	145.00	483.00

Foundation Elev. = 119.00 (ft) Ground Surface Elev.= 136.50 (ft)
 Water table Elev. = 118.00 (ft) Unit weight of Wat. = 62.40 (pcf)

Nº.	Layer Type	Thick. (ft)	Comp. Ratio	Recomp. Ratio	Swell.	Unit Weight (pcf)	Primary Settlement (in.)	Secondary Settlement (in.)
1	INCOMP.	16.5				125.00	0.00	0.00
2	COMP.	19.0	0.037	0.037	0.037	118.00	0.01	0.00
3	INCOMP.	31.0				130.00	0.00	0.00
Total Settlement =							0.01	0.00

N§.	Sublayer		Soil Stresses			Settlement (in.)
	Thick. (ft)	Elev. (ft)	Initial (psf)	Increment (psf)	Max.Past Press. (psf)	
1	INCOMP.					
2	0.90	118.55	2233.60	0.00	2233.60	0.00
3	1.90	117.15	2345.76	0.21	2345.76	0.00
4	1.90	115.25	2451.40	1.50	2451.40	0.00
5	1.90	113.35	2557.04	4.11	2557.04	0.00
6	1.90	111.45	2662.68	7.42	2662.68	0.00
7	1.90	109.55	2768.32	10.63	2768.32	0.00
8	1.90	107.65	2873.96	13.20	2873.96	0.00
9	1.90	105.75	2979.60	14.92	2979.60	0.00
10	1.90	103.85	3085.24	15.85	3085.24	0.00
11	1.90	101.95	3190.88	16.14	3190.88	0.00
12	INCOMP.					
Total Settlement =						0.01 (in.)

RECTANGULAR LOADS

Project Name: North St Culvert, Agawam Project Number : 177018.00
 Client : Woodard-Curran Project Manager: MJO
 Date : 4/6/2023 Computed by : MJO

Increment of stresses obtained using : Boussinesq

Settlement for X = 18.00 (ft) Y = 145.00 (ft)

Footing #	Corner Point P1		Corner Point P2		Load (psf)
	X1(ft)	Y1(ft)	X2(ft)	Y2(ft)	
1	1.50	131.00	7.00	145.00	483.00

Foundation Elev. = 119.00 (ft) Ground Surface Elev.= 136.50 (ft)
 Water table Elev. = 118.00 (ft) Unit weight of Wat. = 62.40 (pcf)

Nº.	Layer Type	Thick. (ft)	Comp. Ratio	Recomp. Ratio	Swell.	Unit Weight (pcf)	Primary Settlement (in.)	Secondary Settlement (in.)
1	INCOMP.	16.5				125.00	0.00	0.00
2	COMP.	19.0	0.037	0.037	0.037	118.00	0.01	0.00
3	INCOMP.	31.0				130.00	0.00	0.00
Total Settlement =							0.01	0.00

N§.	Sublayer		Soil Stresses			Settlement (in.)
	Thick. (ft)	Elev. (ft)	Initial (psf)	Increment (psf)	Max.Past Press. (psf)	
1	INCOMP.					
2	0.90	118.55	2233.60	0.00	2233.60	0.00
3	1.90	117.15	2345.76	0.15	2345.76	0.00
4	1.90	115.25	2451.40	1.08	2451.40	0.00
5	1.90	113.35	2557.04	3.01	2557.04	0.00
6	1.90	111.45	2662.68	5.56	2662.68	0.00
7	1.90	109.55	2768.32	8.16	2768.32	0.00
8	1.90	107.65	2873.96	10.38	2873.96	0.00
9	1.90	105.75	2979.60	12.00	2979.60	0.00
10	1.90	103.85	3085.24	13.03	3085.24	0.00
11	1.90	101.95	3190.88	13.53	3190.88	0.00
12	INCOMP.					
Total Settlement =						0.01 (in.)

RECTANGULAR LOADS

Project Name: North St Culvert, Agawam Project Number : 177018.00
 Client : Woodard-Curran Project Manager: MJO
 Date : 4/6/2023 Computed by : MJO

Increment of stresses obtained using : Boussinesq

Settlement for X = 7.00 (ft) Y = 32.00 (ft)

Footing #	Corner Point P1		Corner Point P2		Load (psf)
	X1(ft)	Y1(ft)	X2(ft)	Y2(ft)	
1	1.50	145.00	34.50	149.00	483.00

Foundation Elev. = 119.00 (ft) Ground Surface Elev.= 136.50 (ft)
 Water table Elev. = 118.00 (ft) Unit weight of Wat. = 62.40 (pcf)

Nº.	Layer Type	Thick. (ft)	Comp. Ratio	Recomp. Ratio	Swell.	Unit Weight (pcf)	Primary Settlement (in.)	Secondary Settlement (in.)
1	INCOMP.	16.5				125.00	0.00	0.00
2	COMP.	19.0	0.037	0.037	0.037	118.00	0.00	0.00
3	INCOMP.	31.0				130.00	0.00	0.00
Total Settlement =							0.00	0.00

N§.	Sublayer		Soil Stresses			Settlement (in.)
	Thick. (ft)	Elev. (ft)	Initial (psf)	Increment (psf)	Max.Past Press. (psf)	
1	INCOMP.					
2	0.90	118.55	2233.60	0.00	2233.60	0.00
3	1.90	117.15	2345.76	0.00	2345.76	0.00
4	1.90	115.25	2451.40	0.00	2451.40	0.00
5	1.90	113.35	2557.04	0.00	2557.04	0.00
6	1.90	111.45	2662.68	0.00	2662.68	0.00
7	1.90	109.55	2768.32	0.00	2768.32	0.00
8	1.90	107.65	2873.96	0.00	2873.96	0.00
9	1.90	105.75	2979.60	0.00	2979.60	0.00
10	1.90	103.85	3085.24	0.00	3085.24	0.00
11	1.90	101.95	3190.88	0.01	3190.88	0.00
12	INCOMP.					
Total Settlement =						0.00 (in.)

RECTANGULAR LOADS

Project Name: North St Culvert, Agawam Project Number : 177018.00
 Client : Woodard-Curran Project Manager: MJO
 Date : 4/6/2023 Computed by : MJO

Increment of stresses obtained using : Boussinesq

Settlement for X = 7.00 (ft) Y = 39.50 (ft)

Footing #	Corner Point P1		Corner Point P2		Load (psf)
	X1(ft)	Y1(ft)	X2(ft)	Y2(ft)	
1	1.50	145.00	34.50	149.00	483.00

Foundation Elev. = 119.00 (ft) Ground Surface Elev.= 136.50 (ft)
 Water table Elev. = 118.00 (ft) Unit weight of Wat. = 62.40 (pcf)

Nº.	Layer Type	Thick. (ft)	Comp. Ratio	Recomp. Ratio	Swell.	Unit Weight (pcf)	Primary Settlement (in.)	Secondary Settlement (in.)
1	INCOMP.	16.5				125.00	0.00	0.00
2	COMP.	19.0	0.037	0.037	0.037	118.00	0.00	0.00
3	INCOMP.	31.0				130.00	0.00	0.00
Total Settlement =							0.00	0.00

N§.	Sublayer		Soil Stresses			Settlement (in.)
	Thick. (ft)	Elev. (ft)	Initial (psf)	Increment (psf)	Max.Past Press. (psf)	
1	INCOMP.					
2	0.90	118.55	2233.60	0.00	2233.60	0.00
3	1.90	117.15	2345.76	0.00	2345.76	0.00
4	1.90	115.25	2451.40	0.00	2451.40	0.00
5	1.90	113.35	2557.04	0.00	2557.04	0.00
6	1.90	111.45	2662.68	0.00	2662.68	0.00
7	1.90	109.55	2768.32	0.00	2768.32	0.00
8	1.90	107.65	2873.96	0.00	2873.96	0.00
9	1.90	105.75	2979.60	0.00	2979.60	0.00
10	1.90	103.85	3085.24	0.01	3085.24	0.00
11	1.90	101.95	3190.88	0.01	3190.88	0.00
12	INCOMP.					
Total Settlement =						0.00 (in.)

RECTANGULAR LOADS

Project Name: North St Culvert, Agawam Project Number : 177018.00
 Client : Woodard-Curran Project Manager: MJO
 Date : 4/6/2023 Computed by : MJO

Increment of stresses obtained using : Boussinesq

Settlement for X = 7.00 (ft) Y = 86.50 (ft)

Footing #	Corner Point P1		Corner Point P2		Load (psf)
	X1(ft)	Y1(ft)	X2(ft)	Y2(ft)	
1	1.50	145.00	34.50	149.00	483.00

Foundation Elev. = 119.00 (ft) Ground Surface Elev.= 136.50 (ft)
 Water table Elev. = 118.00 (ft) Unit weight of Wat. = 62.40 (pcf)

Nº.	Layer Type	Thick. (ft)	Comp. Ratio	Recomp. Ratio	Swell. Ratio	Unit Weight (pcf)	Primary Settlement (in.)	Secondary Settlement (in.)
1	INCOMP.	16.5				125.00	0.00	0.00
2	COMP.	19.0	0.037	0.037	0.037	118.00	0.00	0.00
3	INCOMP.	31.0				130.00	0.00	0.00
Total Settlement =							0.00	0.00

N§.	Sublayer		Soil Stresses			Settlement (in.)
	Thick. (ft)	Elev. (ft)	Initial (psf)	Increment (psf)	Max.Past Press. (psf)	
1	INCOMP.					
2	0.90	118.55	2233.60	0.00	2233.60	0.00
3	1.90	117.15	2345.76	0.00	2345.76	0.00
4	1.90	115.25	2451.40	0.00	2451.40	0.00
5	1.90	113.35	2557.04	0.01	2557.04	0.00
6	1.90	111.45	2662.68	0.01	2662.68	0.00
7	1.90	109.55	2768.32	0.03	2768.32	0.00
8	1.90	107.65	2873.96	0.04	2873.96	0.00
9	1.90	105.75	2979.60	0.07	2979.60	0.00
10	1.90	103.85	3085.24	0.10	3085.24	0.00
11	1.90	101.95	3190.88	0.14	3190.88	0.00
12	INCOMP.					
Total Settlement =						0.00 (in.)

RECTANGULAR LOADS

Project Name: North St Culvert, Agawam Project Number : 177018.00
 Client : Woodard-Curran Project Manager: MJO
 Date : 4/6/2023 Computed by : MJO

Increment of stresses obtained using : Boussinesq

Settlement for X = 7.00 (ft) Y = 109.80 (ft)

Footing #	Corner Point P1		Corner Point P2		Load (psf)
	X1(ft)	Y1(ft)	X2(ft)	Y2(ft)	
1	1.50	145.00	34.50	149.00	483.00

Foundation Elev. = 119.00 (ft) Ground Surface Elev.= 136.50 (ft)
 Water table Elev. = 118.00 (ft) Unit weight of Wat. = 62.40 (pcf)

Nº.	Layer Type	Thick. (ft)	Comp. Ratio	Recomp. Ratio	Swell.	Unit Weight (pcf)	Primary Settlement (in.)	Secondary Settlement (in.)
1	INCOMP.	16.5				125.00	0.00	0.00
2	COMP.	19.0	0.037	0.037	0.037	118.00	0.00	0.00
3	INCOMP.	31.0				130.00	0.00	0.00
Total Settlement =							0.00	0.00

N§.	Sublayer		Soil Stresses			Settlement (in.)
	Thick. (ft)	Elev. (ft)	Initial (psf)	Increment (psf)	Max.Past Press. (psf)	
1	INCOMP.					
2	0.90	118.55	2233.60	0.00	2233.60	0.00
3	1.90	117.15	2345.76	0.00	2345.76	0.00
4	1.90	115.25	2451.40	0.02	2451.40	0.00
5	1.90	113.35	2557.04	0.06	2557.04	0.00
6	1.90	111.45	2662.68	0.13	2662.68	0.00
7	1.90	109.55	2768.32	0.24	2768.32	0.00
8	1.90	107.65	2873.96	0.39	2873.96	0.00
9	1.90	105.75	2979.60	0.58	2979.60	0.00
10	1.90	103.85	3085.24	0.80	3085.24	0.00
11	1.90	101.95	3190.88	1.04	3190.88	0.00
12	INCOMP.					
Total Settlement =						0.00 (in.)

RECTANGULAR LOADS

Project Name: North St Culvert, Agawam Project Number : 177018.00
 Client : Woodard-Curran Project Manager: MJO
 Date : 4/6/2023 Computed by : MJO

Increment of stresses obtained using : Boussinesq

Settlement for X = 7.00 (ft) Y = 124.80 (ft)

Footing #	Corner Point P1		Corner Point P2		Load (psf)
	X1(ft)	Y1(ft)	X2(ft)	Y2(ft)	
1	1.50	145.00	34.50	149.00	483.00

Foundation Elev. = 119.00 (ft) Ground Surface Elev.= 136.50 (ft)
 Water table Elev. = 118.00 (ft) Unit weight of Wat. = 62.40 (pcf)

Nº.	Layer Type	Thick. (ft)	Comp. Ratio	Recomp. Ratio	Swell. Ratio	Unit Weight (pcf)	Primary Settlement (in.)	Secondary Settlement (in.)
1	INCOMP.	16.5				125.00	0.00	0.00
2	COMP.	19.0	0.037	0.037	0.037	118.00	0.00	0.00
3	INCOMP.	31.0				130.00	0.00	0.00
Total Settlement =							0.00	0.00

N§.	Sublayer		Soil Stresses			Settlement (in.)
	Thick. (ft)	Elev. (ft)	Initial (psf)	Increment (psf)	Max.Past Press. (psf)	
1	INCOMP.					
2	0.90	118.55	2233.60	0.00	2233.60	0.00
3	1.90	117.15	2345.76	0.02	2345.76	0.00
4	1.90	115.25	2451.40	0.17	2451.40	0.00
5	1.90	113.35	2557.04	0.53	2557.04	0.00
6	1.90	111.45	2662.68	1.13	2662.68	0.00
7	1.90	109.55	2768.32	1.95	2768.32	0.00
8	1.90	107.65	2873.96	2.91	2873.96	0.00
9	1.90	105.75	2979.60	3.93	2979.60	0.00
10	1.90	103.85	3085.24	4.93	3085.24	0.00
11	1.90	101.95	3190.88	5.85	3190.88	0.00
12	INCOMP.					
Total Settlement =						0.00 (in.)

RECTANGULAR LOADS

Project Name: North St Culvert, Agawam Project Number : 177018.00
 Client : Woodard-Curran Project Manager: MJO
 Date : 4/6/2023 Computed by : MJO

Increment of stresses obtained using : Boussinesq

Settlement for X = 7.00 (ft) Y = 138.00 (ft)

Footing #	Corner Point P1		Corner Point P2		Load (psf)
	X1(ft)	Y1(ft)	X2(ft)	Y2(ft)	
1	1.50	145.00	34.50	149.00	483.00

Foundation Elev. = 119.00 (ft) Ground Surface Elev.= 136.50 (ft)
 Water table Elev. = 118.00 (ft) Unit weight of Wat. = 62.40 (pcf)

Nº.	Layer Type	Thick. (ft)	Comp. Ratio	Recomp. Ratio	Swell.	Unit Weight (pcf)	Primary Settlement (in.)	Secondary Settlement (in.)
1	INCOMP.	16.5				125.00	0.00	0.00
2	COMP.	19.0	0.037	0.037	0.037	118.00	0.03	0.00
3	INCOMP.	31.0				130.00	0.00	0.00
Total Settlement =							0.03	0.00

N§.	Sublayer		Soil Stresses			Settlement (in.)
	Thick. (ft)	Elev. (ft)	Initial (psf)	Increment (psf)	Max.Past Press. (psf)	
1	INCOMP.					
2	0.90	118.55	2233.60	0.02	2233.60	0.00
3	1.90	117.15	2345.76	1.10	2345.76	0.00
4	1.90	115.25	2451.40	6.83	2451.40	0.00
5	1.90	113.35	2557.04	15.51	2557.04	0.00
6	1.90	111.45	2662.68	23.31	2662.68	0.00
7	1.90	109.55	2768.32	28.47	2768.32	0.00
8	1.90	107.65	2873.96	31.04	2873.96	0.00
9	1.90	105.75	2979.60	31.71	2979.60	0.00
10	1.90	103.85	3085.24	31.19	3085.24	0.00
11	1.90	101.95	3190.88	29.98	3190.88	0.00
12	INCOMP.					
Total Settlement =						0.03 (in.)

RECTANGULAR LOADS

Project Name: North St Culvert, Agawam Project Number : 177018.00
 Client : Woodard-Curran Project Manager: MJO
 Date : 4/6/2023 Computed by : MJO

Increment of stresses obtained using : Boussinesq

Settlement for X = 18.00 (ft) Y = 37.00 (ft)

Footing #	Corner Point P1		Corner Point P2		Load (psf)
	X1(ft)	Y1(ft)	X2(ft)	Y2(ft)	
1	1.50	145.00	34.50	149.00	483.00

Foundation Elev. = 119.00 (ft) Ground Surface Elev.= 136.50 (ft)
 Water table Elev. = 118.00 (ft) Unit weight of Wat. = 62.40 (pcf)

Nº.	Layer Type	Thick. (ft)	Comp. Ratio	Recomp. Ratio	Swell.	Unit Weight (pcf)	Primary Settlement (in.)	Secondary Settlement (in.)
1	INCOMP.	16.5				125.00	0.00	0.00
2	COMP.	19.0	0.037	0.037	0.037	118.00	0.00	0.00
3	INCOMP.	31.0				130.00	0.00	0.00
Total Settlement =							0.00	0.00

N§.	Sublayer		Soil Stresses			Settlement (in.)
	Thick. (ft)	Elev. (ft)	Initial (psf)	Increment (psf)	Max.Past Press. (psf)	
1	INCOMP.					
2	0.90	118.55	2233.60	0.00	2233.60	0.00
3	1.90	117.15	2345.76	0.00	2345.76	0.00
4	1.90	115.25	2451.40	0.00	2451.40	0.00
5	1.90	113.35	2557.04	0.00	2557.04	0.00
6	1.90	111.45	2662.68	0.00	2662.68	0.00
7	1.90	109.55	2768.32	0.00	2768.32	0.00
8	1.90	107.65	2873.96	0.00	2873.96	0.00
9	1.90	105.75	2979.60	0.00	2979.60	0.00
10	1.90	103.85	3085.24	0.01	3085.24	0.00
11	1.90	101.95	3190.88	0.01	3190.88	0.00
12	INCOMP.					
Total Settlement =						0.00 (in.)

RECTANGULAR LOADS

Project Name: North St Culvert, Agawam Project Number : 177018.00
 Client : Woodard-Curran Project Manager: MJO
 Date : 4/6/2023 Computed by : MJO

Increment of stresses obtained using : Boussinesq

Settlement for X = 18.00 (ft) Y = 47.50 (ft)

Footing #	Corner Point P1		Corner Point P2		Load (psf)
	X1(ft)	Y1(ft)	X2(ft)	Y2(ft)	
1	1.50	145.00	34.50	149.00	483.00

Foundation Elev. = 119.00 (ft) Ground Surface Elev.= 136.50 (ft)
 Water table Elev. = 118.00 (ft) Unit weight of Wat. = 62.40 (pcf)

Nº.	Layer Type	Thick. (ft)	Comp. Ratio	Recomp. Ratio	Swell.	Unit Weight (pcf)	Primary Settlement (in.)	Secondary Settlement (in.)
1	INCOMP.	16.5				125.00	0.00	0.00
2	COMP.	19.0	0.037	0.037	0.037	118.00	0.00	0.00
3	INCOMP.	31.0				130.00	0.00	0.00
Total Settlement =							0.00	0.00

N§.	Sublayer		Soil Stresses			Settlement (in.)
	Thick. (ft)	Elev. (ft)	Initial (psf)	Increment (psf)	Max.Past Press. (psf)	
1	INCOMP.					
2	0.90	118.55	2233.60	0.00	2233.60	0.00
3	1.90	117.15	2345.76	0.00	2345.76	0.00
4	1.90	115.25	2451.40	0.00	2451.40	0.00
5	1.90	113.35	2557.04	0.00	2557.04	0.00
6	1.90	111.45	2662.68	0.00	2662.68	0.00
7	1.90	109.55	2768.32	0.00	2768.32	0.00
8	1.90	107.65	2873.96	0.00	2873.96	0.00
9	1.90	105.75	2979.60	0.01	2979.60	0.00
10	1.90	103.85	3085.24	0.01	3085.24	0.00
11	1.90	101.95	3190.88	0.01	3190.88	0.00
12	INCOMP.					
Total Settlement =						0.00 (in.)

RECTANGULAR LOADS

Project Name: North St Culvert, Agawam Project Number : 177018.00
 Client : Woodard-Curran Project Manager: MJO
 Date : 4/6/2023 Computed by : MJO

Increment of stresses obtained using : Boussinesq

Settlement for X = 18.00 (ft) Y = 86.50 (ft)

Footing #	Corner Point P1		Corner Point P2		Load (psf)
	X1(ft)	Y1(ft)	X2(ft)	Y2(ft)	
1	1.50	145.00	34.50	149.00	483.00

Foundation Elev. = 119.00 (ft) Ground Surface Elev.= 136.50 (ft)
 Water table Elev. = 118.00 (ft) Unit weight of Wat. = 62.40 (pcf)

Nº.	Layer Type	Thick. (ft)	Comp. Ratio	Recomp. Ratio	Swell.	Unit Weight (pcf)	Primary Settlement (in.)	Secondary Settlement (in.)
1	INCOMP.	16.5				125.00	0.00	0.00
2	COMP.	19.0	0.037	0.037	0.037	118.00	0.00	0.00
3	INCOMP.	31.0				130.00	0.00	0.00
Total Settlement =							0.00	0.00

N§.	Sublayer		Soil Stresses			Settlement (in.)
	Thick. (ft)	Elev. (ft)	Initial (psf)	Increment (psf)	Max.Past Press. (psf)	
1	INCOMP.					
2	0.90	118.55	2233.60	0.00	2233.60	0.00
3	1.90	117.15	2345.76	0.00	2345.76	0.00
4	1.90	115.25	2451.40	0.00	2451.40	0.00
5	1.90	113.35	2557.04	0.01	2557.04	0.00
6	1.90	111.45	2662.68	0.01	2662.68	0.00
7	1.90	109.55	2768.32	0.03	2768.32	0.00
8	1.90	107.65	2873.96	0.05	2873.96	0.00
9	1.90	105.75	2979.60	0.07	2979.60	0.00
10	1.90	103.85	3085.24	0.11	3085.24	0.00
11	1.90	101.95	3190.88	0.15	3190.88	0.00
12	INCOMP.					
Total Settlement =						0.00 (in.)

RECTANGULAR LOADS

Project Name: North St Culvert, Agawam Project Number : 177018.00
 Client : Woodard-Curran Project Manager: MJO
 Date : 4/6/2023 Computed by : MJO

Increment of stresses obtained using : Boussinesq

Settlement for X = 18.00 (ft) Y = 125.50 (ft)

Footing #	Corner Point P1		Corner Point P2		Load (psf)
	X1(ft)	Y1(ft)	X2(ft)	Y2(ft)	
1	1.50	145.00	34.50	149.00	483.00

Foundation Elev. = 119.00 (ft) Ground Surface Elev.= 136.50 (ft)
 Water table Elev. = 118.00 (ft) Unit weight of Wat. = 62.40 (pcf)

Nº.	Layer Type	Thick. (ft)	Comp. Ratio	Recomp. Ratio	Swell. Ratio	Unit Weight (pcf)	Primary Settlement (in.)	Secondary Settlement (in.)
1	INCOMP.	16.5				125.00	0.00	0.00
2	COMP.	19.0	0.037	0.037	0.037	118.00	0.00	0.00
3	INCOMP.	31.0				130.00	0.00	0.00
Total Settlement =							0.00	0.00

N§.	Sublayer		Soil Stresses			Settlement (in.)
	Thick. (ft)	Elev. (ft)	Initial (psf)	Increment (psf)	Max.Past Press. (psf)	
1	INCOMP.					
2	0.90	118.55	2233.60	0.00	2233.60	0.00
3	1.90	117.15	2345.76	0.03	2345.76	0.00
4	1.90	115.25	2451.40	0.23	2451.40	0.00
5	1.90	113.35	2557.04	0.74	2557.04	0.00
6	1.90	111.45	2662.68	1.57	2662.68	0.00
7	1.90	109.55	2768.32	2.68	2768.32	0.00
8	1.90	107.65	2873.96	3.96	2873.96	0.00
9	1.90	105.75	2979.60	5.29	2979.60	0.00
10	1.90	103.85	3085.24	6.55	3085.24	0.00
11	1.90	101.95	3190.88	7.67	3190.88	0.00
12	INCOMP.					
Total Settlement =						0.00 (in.)

RECTANGULAR LOADS

Project Name: North St Culvert, Agawam Project Number : 177018.00
 Client : Woodard-Curran Project Manager: MJO
 Date : 4/6/2023 Computed by : MJO

Increment of stresses obtained using : Boussinesq

Settlement for X = 18.00 (ft) Y = 135.80 (ft)

Footing #	Corner Point P1		Corner Point P2		Load (psf)
	X1(ft)	Y1(ft)	X2(ft)	Y2(ft)	
1	1.50	145.00	34.50	149.00	483.00

Foundation Elev. = 119.00 (ft) Ground Surface Elev.= 136.50 (ft)
 Water table Elev. = 118.00 (ft) Unit weight of Wat. = 62.40 (pcf)

Nº.	Layer Type	Thick. (ft)	Comp. Ratio	Recomp. Ratio	Swell.	Unit Weight (pcf)	Primary Settlement (in.)	Secondary Settlement (in.)	
1	INCOMP.	16.5				125.00	0.00	0.00	
2	COMP.	19.0	0.037	0.037	0.037	118.00	0.02	0.00	
3	INCOMP.	31.0				130.00	0.00	0.00	
Total Settlement =								0.02	0.00

N§.	Sublayer		Soil Stresses			Settlement (in.)
	Thick. (ft)	Elev. (ft)	Initial (psf)	Increment (psf)	Max.Past Press. (psf)	
1	INCOMP.					
2	0.90	118.55	2233.60	0.01	2233.60	0.00
3	1.90	117.15	2345.76	0.50	2345.76	0.00
4	1.90	115.25	2451.40	3.46	2451.40	0.00
5	1.90	113.35	2557.04	9.03	2557.04	0.00
6	1.90	111.45	2662.68	15.51	2662.68	0.00
7	1.90	109.55	2768.32	21.24	2768.32	0.00
8	1.90	107.65	2873.96	25.40	2873.96	0.00
9	1.90	105.75	2979.60	27.89	2979.60	0.00
10	1.90	103.85	3085.24	28.97	3085.24	0.00
11	1.90	101.95	3190.88	29.01	3190.88	0.00
12	INCOMP.					
Total Settlement =						0.02 (in.)

RECTANGULAR LOADS

Project Name: North St Culvert, Agawam Project Number : 177018.00
 Client : Woodard-Curran Project Manager: MJO
 Date : 4/6/2023 Computed by : MJO

Increment of stresses obtained using : Boussinesq

Settlement for X = 18.00 (ft) Y = 145.00 (ft)

Footing #	Corner Point P1		Corner Point P2		Load (psf)
	X1(ft)	Y1(ft)	X2(ft)	Y2(ft)	
1	1.50	145.00	34.50	149.00	483.00

Foundation Elev. = 119.00 (ft) Ground Surface Elev.= 136.50 (ft)
 Water table Elev. = 118.00 (ft) Unit weight of Wat. = 62.40 (pcf)

Nº.	Layer Type	Thick. (ft)	Comp. Ratio	Recomp. Ratio	Swell. Ratio	Unit Weight (pcf)	Primary Settlement (in.)	Secondary Settlement (in.)
1	INCOMP.	16.5				125.00	0.00	0.00
2	COMP.	19.0	0.037	0.037	0.037	118.00	0.17	0.00
3	INCOMP.	31.0				130.00	0.00	0.00
Total Settlement =							0.17	0.00

N§.	Sublayer		Soil Stresses			Settlement (in.)
	Thick. (ft)	Elev. (ft)	Initial (psf)	Increment (psf)	Max.Past Press. (psf)	
1	INCOMP.					
2	0.90	118.55	2233.60	241.36	2233.60	0.02
3	1.90	117.15	2345.76	233.44	2345.76	0.03
4	1.90	115.25	2451.40	202.13	2451.40	0.03
5	1.90	113.35	2557.04	166.31	2557.04	0.02
6	1.90	111.45	2662.68	136.61	2662.68	0.02
7	1.90	109.55	2768.32	113.56	2768.32	0.01
8	1.90	107.65	2873.96	95.65	2873.96	0.01
9	1.90	105.75	2979.60	81.48	2979.60	0.01
10	1.90	103.85	3085.24	70.06	3085.24	0.01
11	1.90	101.95	3190.88	60.74	3190.88	0.01
12	INCOMP.					
Total Settlement =						0.17 (in.)

RECTANGULAR LOADS

Project Name: North St Culvert, Agawam Project Number : 177018.00
 Client : Woodard-Curran Project Manager: MJO
 Date : 4/6/2023 Computed by : MJO

Increment of stresses obtained using : Boussinesq

Settlement for X = 7.00 (ft) Y = 32.00 (ft)

Footing #	Corner Point P1		Corner Point P2		Load (psf)
	X1(ft)	Y1(ft)	X2(ft)	Y2(ft)	
1	29.00	131.00	34.50	145.00	483.00

Foundation Elev. = 119.00 (ft) Ground Surface Elev.= 136.50 (ft)
 Water table Elev. = 118.00 (ft) Unit weight of Wat. = 62.40 (pcf)

Nº.	Layer Type	Thick. (ft)	Comp. Ratio	Recomp. Ratio	Swell.	Unit Weight (pcf)	Primary Settlement (in.)	Secondary Settlement (in.)
1	INCOMP.	16.5				125.00	0.00	0.00
2	COMP.	19.0	0.037	0.037	0.037	118.00	0.00	0.00
3	INCOMP.	31.0				130.00	0.00	0.00
Total Settlement =							0.00	0.00

N§.	Sublayer		Soil Stresses			Settlement (in.)
	Thick. (ft)	Elev. (ft)	Initial (psf)	Increment (psf)	Max.Past Press. (psf)	
1	INCOMP.					
2	0.90	118.55	2233.60	0.00	2233.60	0.00
3	1.90	117.15	2345.76	0.00	2345.76	0.00
4	1.90	115.25	2451.40	0.00	2451.40	0.00
5	1.90	113.35	2557.04	0.00	2557.04	0.00
6	1.90	111.45	2662.68	0.00	2662.68	0.00
7	1.90	109.55	2768.32	0.00	2768.32	0.00
8	1.90	107.65	2873.96	0.00	2873.96	0.00
9	1.90	105.75	2979.60	0.00	2979.60	0.00
10	1.90	103.85	3085.24	0.00	3085.24	0.00
11	1.90	101.95	3190.88	0.01	3190.88	0.00
12	INCOMP.					
Total Settlement =						0.00 (in.)

RECTANGULAR LOADS

Project Name: North St Culvert, Agawam Project Number : 177018.00
 Client : Woodard-Curran Project Manager: MJO
 Date : 4/6/2023 Computed by : MJO

Increment of stresses obtained using : Boussinesq

Settlement for X = 7.00 (ft) Y = 39.50 (ft)

Footing #	Corner Point P1		Corner Point P2		Load (psf)
	X1(ft)	Y1(ft)	X2(ft)	Y2(ft)	
1	29.00	131.00	34.50	145.00	483.00

Foundation Elev. = 119.00 (ft) Ground Surface Elev.= 136.50 (ft)
 Water table Elev. = 118.00 (ft) Unit weight of Wat. = 62.40 (pcf)

Nº.	Layer Type	Thick. (ft)	Comp. Ratio	Recomp. Ratio	Swell.	Unit Weight (pcf)	Primary Settlement (in.)	Secondary Settlement (in.)
1	INCOMP.	16.5				125.00	0.00	0.00
2	COMP.	19.0	0.037	0.037	0.037	118.00	0.00	0.00
3	INCOMP.	31.0				130.00	0.00	0.00
Total Settlement =							0.00	0.00

N§.	Sublayer		Soil Stresses			Settlement (in.)
	Thick. (ft)	Elev. (ft)	Initial (psf)	Increment (psf)	Max.Past Press. (psf)	
1	INCOMP.					
2	0.90	118.55	2233.60	0.00	2233.60	0.00
3	1.90	117.15	2345.76	0.00	2345.76	0.00
4	1.90	115.25	2451.40	0.00	2451.40	0.00
5	1.90	113.35	2557.04	0.00	2557.04	0.00
6	1.90	111.45	2662.68	0.00	2662.68	0.00
7	1.90	109.55	2768.32	0.00	2768.32	0.00
8	1.90	107.65	2873.96	0.00	2873.96	0.00
9	1.90	105.75	2979.60	0.00	2979.60	0.00
10	1.90	103.85	3085.24	0.01	3085.24	0.00
11	1.90	101.95	3190.88	0.01	3190.88	0.00
12	INCOMP.					
Total Settlement =						0.00 (in.)

RECTANGULAR LOADS

Project Name: North St Culvert, Agawam Project Number : 177018.00
 Client : Woodard-Curran Project Manager: MJO
 Date : 4/6/2023 Computed by : MJO

Increment of stresses obtained using : Boussinesq

Settlement for X = 7.00 (ft) Y = 86.50 (ft)

Footing #	Corner Point P1		Corner Point P2		Load (psf)
	X1(ft)	Y1(ft)	X2(ft)	Y2(ft)	
1	29.00	131.00	34.50	145.00	483.00

Foundation Elev. = 119.00 (ft) Ground Surface Elev.= 136.50 (ft)
 Water table Elev. = 118.00 (ft) Unit weight of Wat. = 62.40 (pcf)

Nº.	Layer Type	Thick. (ft)	Comp. Ratio	Recomp. Ratio	Swell.	Unit Weight (pcf)	Primary Settlement (in.)	Secondary Settlement (in.)
1	INCOMP.	16.5				125.00	0.00	0.00
2	COMP.	19.0	0.037	0.037	0.037	118.00	0.00	0.00
3	INCOMP.	31.0				130.00	0.00	0.00
Total Settlement =							0.00	0.00

N§.	Sublayer		Soil Stresses			Settlement (in.)
	Thick. (ft)	Elev. (ft)	Initial (psf)	Increment (psf)	Max.Past Press. (psf)	
1	INCOMP.					
2	0.90	118.55	2233.60	0.00	2233.60	0.00
3	1.90	117.15	2345.76	0.00	2345.76	0.00
4	1.90	115.25	2451.40	0.00	2451.40	0.00
5	1.90	113.35	2557.04	0.01	2557.04	0.00
6	1.90	111.45	2662.68	0.01	2662.68	0.00
7	1.90	109.55	2768.32	0.02	2768.32	0.00
8	1.90	107.65	2873.96	0.04	2873.96	0.00
9	1.90	105.75	2979.60	0.06	2979.60	0.00
10	1.90	103.85	3085.24	0.09	3085.24	0.00
11	1.90	101.95	3190.88	0.12	3190.88	0.00
12	INCOMP.					
Total Settlement =						0.00 (in.)

RECTANGULAR LOADS

Project Name: North St Culvert, Agawam Project Number : 177018.00
 Client : Woodard-Curran Project Manager: MJO
 Date : 4/6/2023 Computed by : MJO

Increment of stresses obtained using : Boussinesq

Settlement for X = 7.00 (ft) Y = 109.80 (ft)

Footing #	Corner Point P1		Corner Point P2		Load (psf)
	X1(ft)	Y1(ft)	X2(ft)	Y2(ft)	
1	29.00	131.00	34.50	145.00	483.00

Foundation Elev. = 119.00 (ft) Ground Surface Elev.= 136.50 (ft)
 Water table Elev. = 118.00 (ft) Unit weight of Wat. = 62.40 (pcf)

Nº.	Layer Type	Thick. (ft)	Comp. Ratio	Recomp. Ratio	Swell.	Unit Weight (pcf)	Primary Settlement (in.)	Secondary Settlement (in.)
1	INCOMP.	16.5				125.00	0.00	0.00
2	COMP.	19.0	0.037	0.037	0.037	118.00	0.00	0.00
3	INCOMP.	31.0				130.00	0.00	0.00
Total Settlement =							0.00	0.00

N§.	Sublayer		Soil Stresses			Settlement (in.)
	Thick. (ft)	Elev. (ft)	Initial (psf)	Increment (psf)	Max.Past Press. (psf)	
1	INCOMP.					
2	0.90	118.55	2233.60	0.00	2233.60	0.00
3	1.90	117.15	2345.76	0.00	2345.76	0.00
4	1.90	115.25	2451.40	0.01	2451.40	0.00
5	1.90	113.35	2557.04	0.04	2557.04	0.00
6	1.90	111.45	2662.68	0.10	2662.68	0.00
7	1.90	109.55	2768.32	0.19	2768.32	0.00
8	1.90	107.65	2873.96	0.30	2873.96	0.00
9	1.90	105.75	2979.60	0.44	2979.60	0.00
10	1.90	103.85	3085.24	0.61	3085.24	0.00
11	1.90	101.95	3190.88	0.79	3190.88	0.00
12	INCOMP.					
Total Settlement =						0.00 (in.)

RECTANGULAR LOADS

Project Name: North St Culvert, Agawam Project Number : 177018.00
 Client : Woodard-Curran Project Manager: MJO
 Date : 4/6/2023 Computed by : MJO

Increment of stresses obtained using : Boussinesq

Settlement for X = 7.00 (ft) Y = 124.80 (ft)

Footing #	Corner Point P1		Corner Point P2		Load (psf)
	X1(ft)	Y1(ft)	X2(ft)	Y2(ft)	
1	29.00	131.00	34.50	145.00	483.00

Foundation Elev. = 119.00 (ft) Ground Surface Elev.= 136.50 (ft)
 Water table Elev. = 118.00 (ft) Unit weight of Wat. = 62.40 (pcf)

Nº.	Layer Type	Thick. (ft)	Comp. Ratio	Recomp. Ratio	Swell.	Unit Weight (pcf)	Primary Settlement (in.)	Secondary Settlement (in.)
1	INCOMP.	16.5				125.00	0.00	0.00
2	COMP.	19.0	0.037	0.037	0.037	118.00	0.00	0.00
3	INCOMP.	31.0				130.00	0.00	0.00
Total Settlement =							0.00	0.00

N§.	Sublayer		Soil Stresses			Settlement (in.)
	Thick. (ft)	Elev. (ft)	Initial (psf)	Increment (psf)	Max.Past Press. (psf)	
1	INCOMP.					
2	0.90	118.55	2233.60	0.00	2233.60	0.00
3	1.90	117.15	2345.76	0.01	2345.76	0.00
4	1.90	115.25	2451.40	0.05	2451.40	0.00
5	1.90	113.35	2557.04	0.18	2557.04	0.00
6	1.90	111.45	2662.68	0.39	2662.68	0.00
7	1.90	109.55	2768.32	0.69	2768.32	0.00
8	1.90	107.65	2873.96	1.06	2873.96	0.00
9	1.90	105.75	2979.60	1.49	2979.60	0.00
10	1.90	103.85	3085.24	1.93	3085.24	0.00
11	1.90	101.95	3190.88	2.36	3190.88	0.00
12	INCOMP.					
Total Settlement =						0.00 (in.)

RECTANGULAR LOADS

Project Name: North St Culvert, Agawam Project Number : 177018.00
 Client : Woodard-Curran Project Manager: MJO
 Date : 4/6/2023 Computed by : MJO

Increment of stresses obtained using : Boussinesq

Settlement for X = 7.00 (ft) Y = 138.00 (ft)

Footing #	Corner Point P1		Corner Point P2		Load (psf)
	X1(ft)	Y1(ft)	X2(ft)	Y2(ft)	
1	29.00	131.00	34.50	145.00	483.00

Foundation Elev. = 119.00 (ft) Ground Surface Elev.= 136.50 (ft)
 Water table Elev. = 118.00 (ft) Unit weight of Wat. = 62.40 (pcf)

Nº.	Layer Type	Thick. (ft)	Comp. Ratio	Recomp. Ratio	Swell.	Unit Weight (pcf)	Primary Settlement (in.)	Secondary Settlement (in.)
1	INCOMP.	16.5				125.00	0.00	0.00
2	COMP.	19.0	0.037	0.037	0.037	118.00	0.00	0.00
3	INCOMP.	31.0				130.00	0.00	0.00
Total Settlement =							0.00	0.00

N§.	Sublayer		Soil Stresses			Settlement (in.)
	Thick. (ft)	Elev. (ft)	Initial (psf)	Increment (psf)	Max.Past Press. (psf)	
1	INCOMP.					
2	0.90	118.55	2233.60	0.00	2233.60	0.00
3	1.90	117.15	2345.76	0.01	2345.76	0.00
4	1.90	115.25	2451.40	0.09	2451.40	0.00
5	1.90	113.35	2557.04	0.30	2557.04	0.00
6	1.90	111.45	2662.68	0.65	2662.68	0.00
7	1.90	109.55	2768.32	1.13	2768.32	0.00
8	1.90	107.65	2873.96	1.71	2873.96	0.00
9	1.90	105.75	2979.60	2.33	2979.60	0.00
10	1.90	103.85	3085.24	2.95	3085.24	0.00
11	1.90	101.95	3190.88	3.52	3190.88	0.00
12	INCOMP.					
Total Settlement =						0.00 (in.)

RECTANGULAR LOADS

Project Name: North St Culvert, Agawam Project Number : 177018.00
 Client : Woodard-Curran Project Manager: MJO
 Date : 4/6/2023 Computed by : MJO

Increment of stresses obtained using : Boussinesq

Settlement for X = 18.00 (ft) Y = 37.00 (ft)

Footing #	Corner Point P1		Corner Point P2		Load (psf)
	X1(ft)	Y1(ft)	X2(ft)	Y2(ft)	
1	29.00	131.00	34.50	145.00	483.00

Foundation Elev. = 119.00 (ft) Ground Surface Elev.= 136.50 (ft)
 Water table Elev. = 118.00 (ft) Unit weight of Wat. = 62.40 (pcf)

Nº.	Layer Type	Thick. (ft)	Comp. Ratio	Recomp. Ratio	Swell.	Unit Weight (pcf)	Primary Settlement (in.)	Secondary Settlement (in.)
1	INCOMP.	16.5				125.00	0.00	0.00
2	COMP.	19.0	0.037	0.037	0.037	118.00	0.00	0.00
3	INCOMP.	31.0				130.00	0.00	0.00
Total Settlement =							0.00	0.00

N§.	Sublayer		Soil Stresses			Settlement (in.)
	Thick. (ft)	Elev. (ft)	Initial (psf)	Increment (psf)	Max.Past Press. (psf)	
1	INCOMP.					
2	0.90	118.55	2233.60	0.00	2233.60	0.00
3	1.90	117.15	2345.76	0.00	2345.76	0.00
4	1.90	115.25	2451.40	0.00	2451.40	0.00
5	1.90	113.35	2557.04	0.00	2557.04	0.00
6	1.90	111.45	2662.68	0.00	2662.68	0.00
7	1.90	109.55	2768.32	0.00	2768.32	0.00
8	1.90	107.65	2873.96	0.00	2873.96	0.00
9	1.90	105.75	2979.60	0.00	2979.60	0.00
10	1.90	103.85	3085.24	0.01	3085.24	0.00
11	1.90	101.95	3190.88	0.01	3190.88	0.00
12	INCOMP.					
Total Settlement =						0.00 (in.)

RECTANGULAR LOADS

Project Name: North St Culvert, Agawam Project Number : 177018.00
 Client : Woodard-Curran Project Manager: MJO
 Date : 4/6/2023 Computed by : MJO

Increment of stresses obtained using : Boussinesq

Settlement for X = 18.00 (ft) Y = 47.50 (ft)

Footing #	Corner Point P1		Corner Point P2		Load (psf)
	X1(ft)	Y1(ft)	X2(ft)	Y2(ft)	
1	29.00	131.00	34.50	145.00	483.00

Foundation Elev. = 119.00 (ft) Ground Surface Elev.= 136.50 (ft)
 Water table Elev. = 118.00 (ft) Unit weight of Wat. = 62.40 (pcf)

Nº.	Layer Type	Thick. (ft)	Comp. Ratio	Recomp. Ratio	Swell.	Unit Weight (pcf)	Primary Settlement (in.)	Secondary Settlement (in.)
1	INCOMP.	16.5				125.00	0.00	0.00
2	COMP.	19.0	0.037	0.037	0.037	118.00	0.00	0.00
3	INCOMP.	31.0				130.00	0.00	0.00
Total Settlement =							0.00	0.00

N§.	Sublayer		Soil Stresses			Settlement (in.)
	Thick. (ft)	Elev. (ft)	Initial (psf)	Increment (psf)	Max.Past Press. (psf)	
1	INCOMP.					
2	0.90	118.55	2233.60	0.00	2233.60	0.00
3	1.90	117.15	2345.76	0.00	2345.76	0.00
4	1.90	115.25	2451.40	0.00	2451.40	0.00
5	1.90	113.35	2557.04	0.00	2557.04	0.00
6	1.90	111.45	2662.68	0.00	2662.68	0.00
7	1.90	109.55	2768.32	0.00	2768.32	0.00
8	1.90	107.65	2873.96	0.00	2873.96	0.00
9	1.90	105.75	2979.60	0.01	2979.60	0.00
10	1.90	103.85	3085.24	0.01	3085.24	0.00
11	1.90	101.95	3190.88	0.01	3190.88	0.00
12	INCOMP.					
Total Settlement =						0.00 (in.)

RECTANGULAR LOADS

Project Name: North St Culvert, Agawam Project Number : 177018.00
 Client : Woodard-Curran Project Manager: MJO
 Date : 4/6/2023 Computed by : MJO

Increment of stresses obtained using : Boussinesq

Settlement for X = 18.00 (ft) Y = 86.50 (ft)

Footing #	Corner Point P1		Corner Point P2		Load (psf)
	X1(ft)	Y1(ft)	X2(ft)	Y2(ft)	
1	29.00	131.00	34.50	145.00	483.00

Foundation Elev. = 119.00 (ft) Ground Surface Elev.= 136.50 (ft)
 Water table Elev. = 118.00 (ft) Unit weight of Wat. = 62.40 (pcf)

Nº.	Layer Type	Thick. (ft)	Comp. Ratio	Recomp. Ratio	Swell.	Unit Weight (pcf)	Primary Settlement (in.)	Secondary Settlement (in.)
1	INCOMP.	16.5				125.00	0.00	0.00
2	COMP.	19.0	0.037	0.037	0.037	118.00	0.00	0.00
3	INCOMP.	31.0				130.00	0.00	0.00
Total Settlement =							0.00	0.00

N§.	Sublayer		Soil Stresses			Settlement (in.)
	Thick. (ft)	Elev. (ft)	Initial (psf)	Increment (psf)	Max.Past Press. (psf)	
1	INCOMP.					
2	0.90	118.55	2233.60	0.00	2233.60	0.00
3	1.90	117.15	2345.76	0.00	2345.76	0.00
4	1.90	115.25	2451.40	0.00	2451.40	0.00
5	1.90	113.35	2557.04	0.01	2557.04	0.00
6	1.90	111.45	2662.68	0.02	2662.68	0.00
7	1.90	109.55	2768.32	0.03	2768.32	0.00
8	1.90	107.65	2873.96	0.06	2873.96	0.00
9	1.90	105.75	2979.60	0.09	2979.60	0.00
10	1.90	103.85	3085.24	0.13	3085.24	0.00
11	1.90	101.95	3190.88	0.17	3190.88	0.00
12	INCOMP.					
Total Settlement =						0.00 (in.)

RECTANGULAR LOADS

Project Name: North St Culvert, Agawam Project Number : 177018.00
 Client : Woodard-Curran Project Manager: MJO
 Date : 4/6/2023 Computed by : MJO

Increment of stresses obtained using : Boussinesq

Settlement for X = 18.00 (ft) Y = 125.50 (ft)

Footing #	Corner Point P1		Corner Point P2		Load (psf)
	X1(ft)	Y1(ft)	X2(ft)	Y2(ft)	
1	29.00	131.00	34.50	145.00	483.00

Foundation Elev. = 119.00 (ft) Ground Surface Elev.= 136.50 (ft)
 Water table Elev. = 118.00 (ft) Unit weight of Wat. = 62.40 (pcf)

Nº.	Layer Type	Thick. (ft)	Comp. Ratio	Recomp. Ratio	Swell.	Unit Weight (pcf)	Primary Settlement (in.)	Secondary Settlement (in.)
1	INCOMP.	16.5				125.00	0.00	0.00
2	COMP.	19.0	0.037	0.037	0.037	118.00	0.00	0.00
3	INCOMP.	31.0				130.00	0.00	0.00
Total Settlement =							0.00	0.00

N§.	Sublayer		Soil Stresses			Settlement (in.)
	Thick. (ft)	Elev. (ft)	Initial (psf)	Increment (psf)	Max.Past Press. (psf)	
1	INCOMP.					
2	0.90	118.55	2233.60	0.00	2233.60	0.00
3	1.90	117.15	2345.76	0.07	2345.76	0.00
4	1.90	115.25	2451.40	0.50	2451.40	0.00
5	1.90	113.35	2557.04	1.47	2557.04	0.00
6	1.90	111.45	2662.68	2.88	2662.68	0.00
7	1.90	109.55	2768.32	4.47	2768.32	0.00
8	1.90	107.65	2873.96	6.02	2873.96	0.00
9	1.90	105.75	2979.60	7.34	2979.60	0.00
10	1.90	103.85	3085.24	8.37	3085.24	0.00
11	1.90	101.95	3190.88	9.08	3190.88	0.00
12	INCOMP.					
Total Settlement =						0.00 (in.)

RECTANGULAR LOADS

Project Name: North St Culvert, Agawam Project Number : 177018.00
 Client : Woodard-Curran Project Manager: MJO
 Date : 4/6/2023 Computed by : MJO

Increment of stresses obtained using : Boussinesq

Settlement for X = 18.00 (ft) Y = 135.80 (ft)

Footing #	Corner Point P1		Corner Point P2		Load (psf)
	X1(ft)	Y1(ft)	X2(ft)	Y2(ft)	
1	29.00	131.00	34.50	145.00	483.00

Foundation Elev. = 119.00 (ft) Ground Surface Elev.= 136.50 (ft)
 Water table Elev. = 118.00 (ft) Unit weight of Wat. = 62.40 (pcf)

Nº.	Layer Type	Thick. (ft)	Comp. Ratio	Recomp. Ratio	Swell. Ratio	Unit Weight (pcf)	Primary Settlement (in.)	Secondary Settlement (in.)
1	INCOMP.	16.5				125.00	0.00	0.00
2	COMP.	19.0	0.037	0.037	0.037	118.00	0.01	0.00
3	INCOMP.	31.0				130.00	0.00	0.00
Total Settlement =							0.01	0.00

N§.	Sublayer		Soil Stresses			Settlement (in.)
	Thick. (ft)	Elev. (ft)	Initial (psf)	Increment (psf)	Max.Past Press. (psf)	
1	INCOMP.					
2	0.90	118.55	2233.60	0.00	2233.60	0.00
3	1.90	117.15	2345.76	0.21	2345.76	0.00
4	1.90	115.25	2451.40	1.50	2451.40	0.00
5	1.90	113.35	2557.04	4.11	2557.04	0.00
6	1.90	111.45	2662.68	7.42	2662.68	0.00
7	1.90	109.55	2768.32	10.63	2768.32	0.00
8	1.90	107.65	2873.96	13.20	2873.96	0.00
9	1.90	105.75	2979.60	14.92	2979.60	0.00
10	1.90	103.85	3085.24	15.85	3085.24	0.00
11	1.90	101.95	3190.88	16.14	3190.88	0.00
12	INCOMP.					
Total Settlement =						0.01 (in.)

RECTANGULAR LOADS

Project Name: North St Culvert, Agawam Project Number : 177018.00
 Client : Woodard-Curran Project Manager: MJO
 Date : 4/6/2023 Computed by : MJO

Increment of stresses obtained using : Boussinesq

Settlement for X = 18.00 (ft) Y = 145.00 (ft)

Footing #	Corner Point P1		Corner Point P2		Load (psf)
	X1(ft)	Y1(ft)	X2(ft)	Y2(ft)	
1	29.00	131.00	34.50	145.00	483.00

Foundation Elev. = 119.00 (ft) Ground Surface Elev.= 136.50 (ft)
 Water table Elev. = 118.00 (ft) Unit weight of Wat. = 62.40 (pcf)

Nº.	Layer Type	Thick. (ft)	Comp. Ratio	Recomp. Ratio	Swell.	Unit Weight (pcf)	Primary Settlement (in.)	Secondary Settlement (in.)
1	INCOMP.	16.5				125.00	0.00	0.00
2	COMP.	19.0	0.037	0.037	0.037	118.00	0.01	0.00
3	INCOMP.	31.0				130.00	0.00	0.00
Total Settlement =							0.01	0.00

N§.	Sublayer		Soil Stresses			Settlement (in.)
	Thick. (ft)	Elev. (ft)	Initial (psf)	Increment (psf)	Max.Past Press. (psf)	
1	INCOMP.					
2	0.90	118.55	2233.60	0.00	2233.60	0.00
3	1.90	117.15	2345.76	0.15	2345.76	0.00
4	1.90	115.25	2451.40	1.08	2451.40	0.00
5	1.90	113.35	2557.04	3.01	2557.04	0.00
6	1.90	111.45	2662.68	5.56	2662.68	0.00
7	1.90	109.55	2768.32	8.16	2768.32	0.00
8	1.90	107.65	2873.96	10.38	2873.96	0.00
9	1.90	105.75	2979.60	12.00	2979.60	0.00
10	1.90	103.85	3085.24	13.03	3085.24	0.00
11	1.90	101.95	3190.88	13.53	3190.88	0.00
12	INCOMP.					
Total Settlement =						0.01 (in.)

RECTANGULAR LOADS

Project Name: North St Culvert, Agawam Project Number : 177018.00
 Client : Woodard-Curran Project Manager: MJO
 Date : 4/6/2023 Computed by : MJO

Increment of stresses obtained using : Boussinesq

Settlement for X = 7.00 (ft) Y = 32.00 (ft)

Footing #	Corner Point P1		Corner Point P2		Load (psf)
	X1(ft)	Y1(ft)	X2(ft)	Y2(ft)	
1	34.50	131.00	49.00	156.00	242.00

Foundation Elev. = 123.75 (ft) Ground Surface Elev.= 136.50 (ft)
 Water table Elev. = 118.00 (ft) Unit weight of Wat. = 62.40 (pcf)

Nº.	Layer Type	Thick. (ft)	Comp. Ratio	Recomp. Ratio	Swell. Ratio	Unit Weight (pcf)	Primary Settlement (in.)	Secondary Settlement (in.)
1	INCOMP.	16.5				125.00	0.00	0.00
2	COMP.	19.0	0.037	0.037	0.037	118.00	0.00	0.00
3	INCOMP.	31.0				130.00	0.00	0.00
Total Settlement =							0.00	0.00

N§.	Sublayer		Soil Stresses			Settlement (in.)
	Thick. (ft)	Elev. (ft)	Initial (psf)	Increment (psf)	Max.Past Press. (psf)	
1	INCOMP.					
2	1.90	119.05	2174.60	0.00	2174.60	0.00
3	1.90	117.15	2345.76	0.00	2345.76	0.00
4	1.90	115.25	2451.40	0.00	2451.40	0.00
5	1.90	113.35	2557.04	0.00	2557.04	0.00
6	1.90	111.45	2662.68	0.00	2662.68	0.00
7	1.90	109.55	2768.32	0.01	2768.32	0.00
8	1.90	107.65	2873.96	0.01	2873.96	0.00
9	1.90	105.75	2979.60	0.01	2979.60	0.00
10	1.90	103.85	3085.24	0.01	3085.24	0.00
11	1.90	101.95	3190.88	0.02	3190.88	0.00
12	INCOMP.					
Total Settlement =						0.00 (in.)

RECTANGULAR LOADS

Project Name: North St Culvert, Agawam Project Number : 177018.00
 Client : Woodard-Curran Project Manager: MJO
 Date : 4/6/2023 Computed by : MJO

Increment of stresses obtained using : Boussinesq

Settlement for X = 7.00 (ft) Y = 39.50 (ft)

Footing #	Corner Point P1		Corner Point P2		Load (psf)
	X1(ft)	Y1(ft)	X2(ft)	Y2(ft)	
1	34.50	131.00	49.00	156.00	242.00

Foundation Elev. = 123.75 (ft) Ground Surface Elev.= 136.50 (ft)
 Water table Elev. = 118.00 (ft) Unit weight of Wat. = 62.40 (pcf)

Nº.	Layer Type	Thick. (ft)	Comp. Ratio	Recomp. Ratio	Swell.	Unit Weight (pcf)	Primary Settlement (in.)	Secondary Settlement (in.)
1	INCOMP.	16.5				125.00	0.00	0.00
2	COMP.	19.0	0.037	0.037	0.037	118.00	0.00	0.00
3	INCOMP.	31.0				130.00	0.00	0.00
Total Settlement =							0.00	0.00

N§.	Sublayer		Soil Stresses			Settlement (in.)
	Thick. (ft)	Elev. (ft)	Initial (psf)	Increment (psf)	Max.Past Press. (psf)	
1	INCOMP.					
2	1.90	119.05	2174.60	0.00	2174.60	0.00
3	1.90	117.15	2345.76	0.00	2345.76	0.00
4	1.90	115.25	2451.40	0.00	2451.40	0.00
5	1.90	113.35	2557.04	0.00	2557.04	0.00
6	1.90	111.45	2662.68	0.01	2662.68	0.00
7	1.90	109.55	2768.32	0.01	2768.32	0.00
8	1.90	107.65	2873.96	0.01	2873.96	0.00
9	1.90	105.75	2979.60	0.02	2979.60	0.00
10	1.90	103.85	3085.24	0.02	3085.24	0.00
11	1.90	101.95	3190.88	0.03	3190.88	0.00
12	INCOMP.					
Total Settlement =						0.00 (in.)

RECTANGULAR LOADS

Project Name: North St Culvert, Agawam Project Number : 177018.00
 Client : Woodard-Curran Project Manager: MJO
 Date : 4/6/2023 Computed by : MJO

Increment of stresses obtained using : Boussinesq

Settlement for X = 7.00 (ft) Y = 86.50 (ft)

Footing #	Corner Point P1		Corner Point P2		Load (psf)
	X1(ft)	Y1(ft)	X2(ft)	Y2(ft)	
1	34.50	131.00	49.00	156.00	242.00

Foundation Elev. = 123.75 (ft) Ground Surface Elev.= 136.50 (ft)
 Water table Elev. = 118.00 (ft) Unit weight of Wat. = 62.40 (pcf)

Nº.	Layer Type	Thick. (ft)	Comp. Ratio	Recomp. Ratio	Swell. Ratio	Unit Weight (pcf)	Primary Settlement (in.)	Secondary Settlement (in.)
1	INCOMP.	16.5				125.00	0.00	0.00
2	COMP.	19.0	0.037	0.037	0.037	118.00	0.00	0.00
3	INCOMP.	31.0				130.00	0.00	0.00
Total Settlement =							0.00	0.00

N§.	Sublayer		Soil Stresses			Settlement (in.)
	Thick. (ft)	Elev. (ft)	Initial (psf)	Increment (psf)	Max.Past Press. (psf)	
1	INCOMP.					
2	1.90	119.05	2174.60	0.00	2174.60	0.00
3	1.90	117.15	2345.76	0.01	2345.76	0.00
4	1.90	115.25	2451.40	0.02	2451.40	0.00
5	1.90	113.35	2557.04	0.04	2557.04	0.00
6	1.90	111.45	2662.68	0.06	2662.68	0.00
7	1.90	109.55	2768.32	0.09	2768.32	0.00
8	1.90	107.65	2873.96	0.13	2873.96	0.00
9	1.90	105.75	2979.60	0.17	2979.60	0.00
10	1.90	103.85	3085.24	0.22	3085.24	0.00
11	1.90	101.95	3190.88	0.28	3190.88	0.00
12	INCOMP.					
Total Settlement =						0.00 (in.)

RECTANGULAR LOADS

Project Name: North St Culvert, Agawam Project Number : 177018.00
 Client : Woodard-Curran Project Manager: MJO
 Date : 4/6/2023 Computed by : MJO

Increment of stresses obtained using : Boussinesq

Settlement for X = 7.00 (ft) Y = 109.80 (ft)

Footing #	Corner Point P1		Corner Point P2		Load (psf)
	X1(ft)	Y1(ft)	X2(ft)	Y2(ft)	
1	34.50	131.00	49.00	156.00	242.00

Foundation Elev. = 123.75 (ft) Ground Surface Elev.= 136.50 (ft)
 Water table Elev. = 118.00 (ft) Unit weight of Wat. = 62.40 (pcf)

Nº.	Layer Type	Thick. (ft)	Comp. Ratio	Recomp. Ratio	Swell.	Unit Weight (pcf)	Primary Settlement (in.)	Secondary Settlement (in.)
1	INCOMP.	16.5				125.00	0.00	0.00
2	COMP.	19.0	0.037	0.037	0.037	118.00	0.00	0.00
3	INCOMP.	31.0				130.00	0.00	0.00
Total Settlement =							0.00	0.00

N§.	Sublayer		Soil Stresses			Settlement (in.)
	Thick. (ft)	Elev. (ft)	Initial (psf)	Increment (psf)	Max.Past Press. (psf)	
1	INCOMP.					
2	1.90	119.05	2174.60	0.02	2174.60	0.00
3	1.90	117.15	2345.76	0.05	2345.76	0.00
4	1.90	115.25	2451.40	0.11	2451.40	0.00
5	1.90	113.35	2557.04	0.19	2557.04	0.00
6	1.90	111.45	2662.68	0.29	2662.68	0.00
7	1.90	109.55	2768.32	0.43	2768.32	0.00
8	1.90	107.65	2873.96	0.58	2873.96	0.00
9	1.90	105.75	2979.60	0.76	2979.60	0.00
10	1.90	103.85	3085.24	0.95	3085.24	0.00
11	1.90	101.95	3190.88	1.16	3190.88	0.00
12	INCOMP.					
Total Settlement =						0.00 (in.)

RECTANGULAR LOADS

Project Name: North St Culvert, Agawam Project Number : 177018.00
 Client : Woodard-Curran Project Manager: MJO
 Date : 4/6/2023 Computed by : MJO

Increment of stresses obtained using : Boussinesq

Settlement for X = 7.00 (ft) Y = 124.80 (ft)

Footing #	Corner Point P1		Corner Point P2		Load (psf)
	X1(ft)	Y1(ft)	X2(ft)	Y2(ft)	
1	34.50	131.00	49.00	156.00	242.00

Foundation Elev. = 123.75 (ft) Ground Surface Elev.= 136.50 (ft)
 Water table Elev. = 118.00 (ft) Unit weight of Wat. = 62.40 (pcf)

Nº.	Layer Type	Thick. (ft)	Comp. Ratio	Recomp. Ratio	Swell.	Unit Weight (pcf)	Primary Settlement (in.)	Secondary Settlement (in.)
1	INCOMP.	16.5				125.00	0.00	0.00
2	COMP.	19.0	0.037	0.037	0.037	118.00	0.00	0.00
3	INCOMP.	31.0				130.00	0.00	0.00
Total Settlement =							0.00	0.00

N§.	Sublayer		Soil Stresses			Settlement (in.)
	Thick. (ft)	Elev. (ft)	Initial (psf)	Increment (psf)	Max.Past Press. (psf)	
1	INCOMP.					
2	1.90	119.05	2174.60	0.05	2174.60	0.00
3	1.90	117.15	2345.76	0.14	2345.76	0.00
4	1.90	115.25	2451.40	0.28	2451.40	0.00
5	1.90	113.35	2557.04	0.48	2557.04	0.00
6	1.90	111.45	2662.68	0.74	2662.68	0.00
7	1.90	109.55	2768.32	1.05	2768.32	0.00
8	1.90	107.65	2873.96	1.39	2873.96	0.00
9	1.90	105.75	2979.60	1.76	2979.60	0.00
10	1.90	103.85	3085.24	2.15	3085.24	0.00
11	1.90	101.95	3190.88	2.53	3190.88	0.00
12	INCOMP.					
Total Settlement =						0.00 (in.)

RECTANGULAR LOADS

Project Name: North St Culvert, Agawam Project Number : 177018.00
 Client : Woodard-Curran Project Manager: MJO
 Date : 4/6/2023 Computed by : MJO

Increment of stresses obtained using : Boussinesq

Settlement for X = 7.00 (ft) Y = 138.00 (ft)

Footing #	Corner Point P1		Corner Point P2		Load (psf)
	X1(ft)	Y1(ft)	X2(ft)	Y2(ft)	
1	34.50	131.00	49.00	156.00	242.00

Foundation Elev. = 123.75 (ft) Ground Surface Elev.= 136.50 (ft)
 Water table Elev. = 118.00 (ft) Unit weight of Wat. = 62.40 (pcf)

Nº.	Layer Type	Thick. (ft)	Comp. Ratio	Recomp. Ratio	Swell.	Unit Weight (pcf)	Primary Settlement (in.)	Secondary Settlement (in.)
1	INCOMP.	16.5				125.00	0.00	0.00
2	COMP.	19.0	0.037	0.037	0.037	118.00	0.00	0.00
3	INCOMP.	31.0				130.00	0.00	0.00
Total Settlement =							0.00	0.00

N§.	Sublayer		Soil Stresses			Settlement (in.)
	Thick. (ft)	Elev. (ft)	Initial (psf)	Increment (psf)	Max.Past Press. (psf)	
1	INCOMP.					
2	1.90	119.05	2174.60	0.09	2174.60	0.00
3	1.90	117.15	2345.76	0.23	2345.76	0.00
4	1.90	115.25	2451.40	0.46	2451.40	0.00
5	1.90	113.35	2557.04	0.77	2557.04	0.00
6	1.90	111.45	2662.68	1.17	2662.68	0.00
7	1.90	109.55	2768.32	1.63	2768.32	0.00
8	1.90	107.65	2873.96	2.14	2873.96	0.00
9	1.90	105.75	2979.60	2.66	2979.60	0.00
10	1.90	103.85	3085.24	3.18	3085.24	0.00
11	1.90	101.95	3190.88	3.69	3190.88	0.00
12	INCOMP.					
Total Settlement =						0.00 (in.)

RECTANGULAR LOADS

Project Name: North St Culvert, Agawam Project Number : 177018.00
 Client : Woodard-Curran Project Manager: MJO
 Date : 4/6/2023 Computed by : MJO

Increment of stresses obtained using : Boussinesq

Settlement for X = 18.00 (ft) Y = 37.00 (ft)

Footing #	Corner Point P1		Corner Point P2		Load (psf)
	X1(ft)	Y1(ft)	X2(ft)	Y2(ft)	
1	34.50	131.00	49.00	156.00	242.00

Foundation Elev. = 123.75 (ft) Ground Surface Elev.= 136.50 (ft)
 Water table Elev. = 118.00 (ft) Unit weight of Wat. = 62.40 (pcf)

Nº.	Layer Type	Thick. (ft)	Comp. Ratio	Recomp. Ratio	Swell. Ratio	Unit Weight (pcf)	Primary Settlement (in.)	Secondary Settlement (in.)
1	INCOMP.	16.5				125.00	0.00	0.00
2	COMP.	19.0	0.037	0.037	0.037	118.00	0.00	0.00
3	INCOMP.	31.0				130.00	0.00	0.00
Total Settlement =							0.00	0.00

N§.	Sublayer		Soil Stresses			Settlement (in.)
	Thick. (ft)	Elev. (ft)	Initial (psf)	Increment (psf)	Max.Past Press. (psf)	
1	INCOMP.					
2	1.90	119.05	2174.60	0.00	2174.60	0.00
3	1.90	117.15	2345.76	0.00	2345.76	0.00
4	1.90	115.25	2451.40	0.00	2451.40	0.00
5	1.90	113.35	2557.04	0.00	2557.04	0.00
6	1.90	111.45	2662.68	0.01	2662.68	0.00
7	1.90	109.55	2768.32	0.01	2768.32	0.00
8	1.90	107.65	2873.96	0.01	2873.96	0.00
9	1.90	105.75	2979.60	0.02	2979.60	0.00
10	1.90	103.85	3085.24	0.02	3085.24	0.00
11	1.90	101.95	3190.88	0.03	3190.88	0.00
12	INCOMP.					
Total Settlement =						0.00 (in.)

RECTANGULAR LOADS

Project Name: North St Culvert, Agawam Project Number : 177018.00
 Client : Woodard-Curran Project Manager: MJO
 Date : 4/6/2023 Computed by : MJO

Increment of stresses obtained using : Boussinesq

Settlement for X = 18.00 (ft) Y = 47.50 (ft)

Footing #	Corner Point P1		Corner Point P2		Load (psf)
	X1(ft)	Y1(ft)	X2(ft)	Y2(ft)	
1	34.50	131.00	49.00	156.00	242.00

Foundation Elev. = 123.75 (ft) Ground Surface Elev.= 136.50 (ft)
 Water table Elev. = 118.00 (ft) Unit weight of Wat. = 62.40 (pcf)

Nº.	Layer Type	Thick. (ft)	Comp. Ratio	Recomp. Ratio	Swell.	Unit Weight (pcf)	Primary Settlement (in.)	Secondary Settlement (in.)
1	INCOMP.	16.5				125.00	0.00	0.00
2	COMP.	19.0	0.037	0.037	0.037	118.00	0.00	0.00
3	INCOMP.	31.0				130.00	0.00	0.00
Total Settlement =							0.00	0.00

N§.	Sublayer		Soil Stresses			Settlement (in.)
	Thick. (ft)	Elev. (ft)	Initial (psf)	Increment (psf)	Max.Past Press. (psf)	
1	INCOMP.					
2	1.90	119.05	2174.60	0.00	2174.60	0.00
3	1.90	117.15	2345.76	0.00	2345.76	0.00
4	1.90	115.25	2451.40	0.00	2451.40	0.00
5	1.90	113.35	2557.04	0.01	2557.04	0.00
6	1.90	111.45	2662.68	0.01	2662.68	0.00
7	1.90	109.55	2768.32	0.01	2768.32	0.00
8	1.90	107.65	2873.96	0.02	2873.96	0.00
9	1.90	105.75	2979.60	0.03	2979.60	0.00
10	1.90	103.85	3085.24	0.03	3085.24	0.00
11	1.90	101.95	3190.88	0.04	3190.88	0.00
12	INCOMP.					
Total Settlement =						0.00 (in.)

RECTANGULAR LOADS

Project Name: North St Culvert, Agawam Project Number : 177018.00
 Client : Woodard-Curran Project Manager: MJO
 Date : 4/6/2023 Computed by : MJO

Increment of stresses obtained using : Boussinesq

Settlement for X = 18.00 (ft) Y = 86.50 (ft)

Footing #	Corner Point P1		Corner Point P2		Load (psf)
	X1(ft)	Y1(ft)	X2(ft)	Y2(ft)	
1	34.50	131.00	49.00	156.00	242.00

Foundation Elev. = 123.75 (ft) Ground Surface Elev.= 136.50 (ft)
 Water table Elev. = 118.00 (ft) Unit weight of Wat. = 62.40 (pcf)

Nº.	Layer Type	Thick. (ft)	Comp. Ratio	Recomp. Ratio	Swell. Ratio	Unit Weight (pcf)	Primary Settlement (in.)	Secondary Settlement (in.)
1	INCOMP.	16.5				125.00	0.00	0.00
2	COMP.	19.0	0.037	0.037	0.037	118.00	0.00	0.00
3	INCOMP.	31.0				130.00	0.00	0.00
Total Settlement =							0.00	0.00

N§.	Sublayer		Soil Stresses			Settlement (in.)
	Thick. (ft)	Elev. (ft)	Initial (psf)	Increment (psf)	Max.Past Press. (psf)	
1	INCOMP.					
2	1.90	119.05	2174.60	0.01	2174.60	0.00
3	1.90	117.15	2345.76	0.02	2345.76	0.00
4	1.90	115.25	2451.40	0.03	2451.40	0.00
5	1.90	113.35	2557.04	0.06	2557.04	0.00
6	1.90	111.45	2662.68	0.09	2662.68	0.00
7	1.90	109.55	2768.32	0.14	2768.32	0.00
8	1.90	107.65	2873.96	0.19	2873.96	0.00
9	1.90	105.75	2979.60	0.26	2979.60	0.00
10	1.90	103.85	3085.24	0.33	3085.24	0.00
11	1.90	101.95	3190.88	0.41	3190.88	0.00
12	INCOMP.					
Total Settlement =						0.00 (in.)

RECTANGULAR LOADS

Project Name: North St Culvert, Agawam Project Number : 177018.00
 Client : Woodard-Curran Project Manager: MJO
 Date : 4/6/2023 Computed by : MJO

Increment of stresses obtained using : Boussinesq

Settlement for X = 18.00 (ft) Y = 125.50 (ft)

Footing #	Corner Point P1		Corner Point P2		Load (psf)
	X1(ft)	Y1(ft)	X2(ft)	Y2(ft)	
1	34.50	131.00	49.00	156.00	242.00

Foundation Elev. = 123.75 (ft) Ground Surface Elev.= 136.50 (ft)
 Water table Elev. = 118.00 (ft) Unit weight of Wat. = 62.40 (pcf)

Nº.	Layer Type	Thick. (ft)	Comp. Ratio	Recomp. Ratio	Swell.	Unit Weight (pcf)	Primary Settlement (in.)	Secondary Settlement (in.)
1	INCOMP.	16.5				125.00	0.00	0.00
2	COMP.	19.0	0.037	0.037	0.037	118.00	0.00	0.00
3	INCOMP.	31.0				130.00	0.00	0.00
Total Settlement =							0.00	0.00

N§.	Sublayer		Soil Stresses			Settlement (in.)
	Thick. (ft)	Elev. (ft)	Initial (psf)	Increment (psf)	Max.Past Press. (psf)	
1	INCOMP.					
2	1.90	119.05	2174.60	0.26	2174.60	0.00
3	1.90	117.15	2345.76	0.67	2345.76	0.00
4	1.90	115.25	2451.40	1.28	2451.40	0.00
5	1.90	113.35	2557.04	2.06	2557.04	0.00
6	1.90	111.45	2662.68	2.95	2662.68	0.00
7	1.90	109.55	2768.32	3.88	2768.32	0.00
8	1.90	107.65	2873.96	4.81	2873.96	0.00
9	1.90	105.75	2979.60	5.67	2979.60	0.00
10	1.90	103.85	3085.24	6.45	3085.24	0.00
11	1.90	101.95	3190.88	7.12	3190.88	0.00
12	INCOMP.					
Total Settlement =						0.00 (in.)

RECTANGULAR LOADS

Project Name: North St Culvert, Agawam Project Number : 177018.00
 Client : Woodard-Curran Project Manager: MJO
 Date : 4/6/2023 Computed by : MJO

Increment of stresses obtained using : Boussinesq

Settlement for X = 18.00 (ft) Y = 135.80 (ft)

Footing #	Corner Point P1		Corner Point P2		Load (psf)
	X1(ft)	Y1(ft)	X2(ft)	Y2(ft)	
1	34.50	131.00	49.00	156.00	242.00

Foundation Elev. = 123.75 (ft) Ground Surface Elev.= 136.50 (ft)
 Water table Elev. = 118.00 (ft) Unit weight of Wat. = 62.40 (pcf)

Nº.	Layer Type	Thick. (ft)	Comp. Ratio	Recomp. Ratio	Swell. Ratio	Unit Weight (pcf)	Primary Settlement (in.)	Secondary Settlement (in.)
1	INCOMP.	16.5				125.00	0.00	0.00
2	COMP.	19.0	0.037	0.037	0.037	118.00	0.01	0.00
3	INCOMP.	31.0				130.00	0.00	0.00
Total Settlement =							0.01	0.00

N§.	Sublayer		Soil Stresses			Settlement (in.)
	Thick. (ft)	Elev. (ft)	Initial (psf)	Increment (psf)	Max.Past Press. (psf)	
1	INCOMP.					
2	1.90	119.05	2174.60	0.54	2174.60	0.00
3	1.90	117.15	2345.76	1.34	2345.76	0.00
4	1.90	115.25	2451.40	2.49	2451.40	0.00
5	1.90	113.35	2557.04	3.89	2557.04	0.00
6	1.90	111.45	2662.68	5.39	2662.68	0.00
7	1.90	109.55	2768.32	6.87	2768.32	0.00
8	1.90	107.65	2873.96	8.22	2873.96	0.00
9	1.90	105.75	2979.60	9.40	2979.60	0.00
10	1.90	103.85	3085.24	10.36	3085.24	0.00
11	1.90	101.95	3190.88	11.10	3190.88	0.00
12	INCOMP.					
Total Settlement =						0.01 (in.)

RECTANGULAR LOADS

Project Name: North St Culvert, Agawam Project Number : 177018.00
 Client : Woodard-Curran Project Manager: MJO
 Date : 4/6/2023 Computed by : MJO

Increment of stresses obtained using : Boussinesq

Settlement for X = 18.00 (ft) Y = 145.00 (ft)

Footing #	Corner Point P1		Corner Point P2		Load (psf)
	X1(ft)	Y1(ft)	X2(ft)	Y2(ft)	
1	34.50	131.00	49.00	156.00	242.00

Foundation Elev. = 123.75 (ft) Ground Surface Elev.= 136.50 (ft)
 Water table Elev. = 118.00 (ft) Unit weight of Wat. = 62.40 (pcf)

Nº.	Layer Type	Thick. (ft)	Comp. Ratio	Recomp. Ratio	Swell. Ratio	Unit Weight (pcf)	Primary Settlement (in.)	Secondary Settlement (in.)
1	INCOMP.	16.5				125.00	0.00	0.00
2	COMP.	19.0	0.037	0.037	0.037	118.00	0.01	0.00
3	INCOMP.	31.0				130.00	0.00	0.00
Total Settlement =							0.01	0.00

N§.	Sublayer		Soil Stresses			Settlement (in.)
	Thick. (ft)	Elev. (ft)	Initial (psf)	Increment (psf)	Max.Past Press. (psf)	
1	INCOMP.					
2	1.90	119.05	2174.60	0.63	2174.60	0.00
3	1.90	117.15	2345.76	1.55	2345.76	0.00
4	1.90	115.25	2451.40	2.86	2451.40	0.00
5	1.90	113.35	2557.04	4.45	2557.04	0.00
6	1.90	111.45	2662.68	6.13	2662.68	0.00
7	1.90	109.55	2768.32	7.77	2768.32	0.00
8	1.90	107.65	2873.96	9.25	2873.96	0.00
9	1.90	105.75	2979.60	10.50	2979.60	0.00
10	1.90	103.85	3085.24	11.51	3085.24	0.00
11	1.90	101.95	3190.88	12.26	3190.88	0.00
12	INCOMP.					
Total Settlement =						0.01 (in.)

RECTANGULAR LOADS

Project Name: North St Culvert, Agawam Project Number : 177018.00
 Client : Woodard-Curran Project Manager: MJO
 Date : 4/6/2023 Computed by : MJO

Increment of stresses obtained using : Boussinesq

Settlement for X = 7.00 (ft) Y = 32.00 (ft)

Footing #	Corner Point P1		Corner Point P2		Load (psf)
	X1(ft)	Y1(ft)	X2(ft)	Y2(ft)	
1	34.50	131.00	49.00	156.00	302.00

Foundation Elev. = 128.50 (ft) Ground Surface Elev.= 136.50 (ft)
 Water table Elev. = 118.00 (ft) Unit weight of Wat. = 62.40 (pcf)

Nº.	Layer Type	Thick. (ft)	Comp. Ratio	Recomp. Ratio	Swell.	Unit Weight (pcf)	Primary Settlement (in.)	Secondary Settlement (in.)
1	INCOMP.	16.5				125.00	0.00	0.00
2	COMP.	19.0	0.037	0.037	0.037	118.00	0.00	0.00
3	INCOMP.	31.0				130.00	0.00	0.00
Total Settlement =							0.00	0.00

N§.	Sublayer		Soil Stresses			Settlement (in.)
	Thick. (ft)	Elev. (ft)	Initial (psf)	Increment (psf)	Max.Past Press. (psf)	
1	INCOMP.					
2	1.90	119.05	2174.60	0.00	2174.60	0.00
3	1.90	117.15	2345.76	0.00	2345.76	0.00
4	1.90	115.25	2451.40	0.01	2451.40	0.00
5	1.90	113.35	2557.04	0.01	2557.04	0.00
6	1.90	111.45	2662.68	0.01	2662.68	0.00
7	1.90	109.55	2768.32	0.02	2768.32	0.00
8	1.90	107.65	2873.96	0.02	2873.96	0.00
9	1.90	105.75	2979.60	0.03	2979.60	0.00
10	1.90	103.85	3085.24	0.03	3085.24	0.00
11	1.90	101.95	3190.88	0.04	3190.88	0.00
12	INCOMP.					
Total Settlement =						0.00 (in.)

RECTANGULAR LOADS

Project Name: North St Culvert, Agawam Project Number : 177018.00
 Client : Woodard-Curran Project Manager: MJO
 Date : 4/6/2023 Computed by : MJO

Increment of stresses obtained using : Boussinesq

Settlement for X = 7.00 (ft) Y = 39.50 (ft)

Footing #	Corner Point P1		Corner Point P2		Load (psf)
	X1(ft)	Y1(ft)	X2(ft)	Y2(ft)	
1	34.50	131.00	49.00	156.00	302.00

Foundation Elev. = 128.50 (ft) Ground Surface Elev.= 136.50 (ft)
 Water table Elev. = 118.00 (ft) Unit weight of Wat. = 62.40 (pcf)

Nº.	Layer Type	Thick. (ft)	Comp. Ratio	Recomp. Ratio	Swell.	Unit Weight (pcf)	Primary Settlement (in.)	Secondary Settlement (in.)
1	INCOMP.	16.5				125.00	0.00	0.00
2	COMP.	19.0	0.037	0.037	0.037	118.00	0.00	0.00
3	INCOMP.	31.0				130.00	0.00	0.00
Total Settlement =							0.00	0.00

N§.	Sublayer		Soil Stresses			Settlement (in.)
	Thick. (ft)	Elev. (ft)	Initial (psf)	Increment (psf)	Max.Past Press. (psf)	
1	INCOMP.					
2	1.90	119.05	2174.60	0.00	2174.60	0.00
3	1.90	117.15	2345.76	0.00	2345.76	0.00
4	1.90	115.25	2451.40	0.01	2451.40	0.00
5	1.90	113.35	2557.04	0.01	2557.04	0.00
6	1.90	111.45	2662.68	0.02	2662.68	0.00
7	1.90	109.55	2768.32	0.02	2768.32	0.00
8	1.90	107.65	2873.96	0.03	2873.96	0.00
9	1.90	105.75	2979.60	0.04	2979.60	0.00
10	1.90	103.85	3085.24	0.05	3085.24	0.00
11	1.90	101.95	3190.88	0.06	3190.88	0.00
12	INCOMP.					
Total Settlement =						0.00 (in.)

RECTANGULAR LOADS

Project Name: North St Culvert, Agawam Project Number : 177018.00
 Client : Woodard-Curran Project Manager: MJO
 Date : 4/6/2023 Computed by : MJO

Increment of stresses obtained using : Boussinesq

Settlement for X = 7.00 (ft) Y = 86.50 (ft)

Footing #	Corner Point P1		Corner Point P2		Load (psf)
	X1(ft)	Y1(ft)	X2(ft)	Y2(ft)	
1	34.50	131.00	49.00	156.00	302.00

Foundation Elev. = 128.50 (ft) Ground Surface Elev.= 136.50 (ft)
 Water table Elev. = 118.00 (ft) Unit weight of Wat. = 62.40 (pcf)

Nº.	Layer Type	Thick. (ft)	Comp. Ratio	Recomp. Ratio	Swell.	Unit Weight (pcf)	Primary Settlement (in.)	Secondary Settlement (in.)
1	INCOMP.	16.5				125.00	0.00	0.00
2	COMP.	19.0	0.037	0.037	0.037	118.00	0.00	0.00
3	INCOMP.	31.0				130.00	0.00	0.00
Total Settlement =							0.00	0.00

N§.	Sublayer		Soil Stresses			Settlement (in.)
	Thick. (ft)	Elev. (ft)	Initial (psf)	Increment (psf)	Max.Past Press. (psf)	
1	INCOMP.					
2	1.90	119.05	2174.60	0.04	2174.60	0.00
3	1.90	117.15	2345.76	0.06	2345.76	0.00
4	1.90	115.25	2451.40	0.09	2451.40	0.00
5	1.90	113.35	2557.04	0.14	2557.04	0.00
6	1.90	111.45	2662.68	0.19	2662.68	0.00
7	1.90	109.55	2768.32	0.25	2768.32	0.00
8	1.90	107.65	2873.96	0.31	2873.96	0.00
9	1.90	105.75	2979.60	0.39	2979.60	0.00
10	1.90	103.85	3085.24	0.47	3085.24	0.00
11	1.90	101.95	3190.88	0.56	3190.88	0.00
12	INCOMP.					
Total Settlement =						0.00 (in.)

RECTANGULAR LOADS

Project Name: North St Culvert, Agawam Project Number : 177018.00
 Client : Woodard-Curran Project Manager: MJO
 Date : 4/6/2023 Computed by : MJO

Increment of stresses obtained using : Boussinesq

Settlement for X = 7.00 (ft) Y = 109.80 (ft)

Footing #	Corner Point P1		Corner Point P2		Load (psf)
	X1(ft)	Y1(ft)	X2(ft)	Y2(ft)	
1	34.50	131.00	49.00	156.00	302.00

Foundation Elev. = 128.50 (ft) Ground Surface Elev.= 136.50 (ft)
 Water table Elev. = 118.00 (ft) Unit weight of Wat. = 62.40 (pcf)

Nº.	Layer Type	Thick. (ft)	Comp. Ratio	Recomp. Ratio	Swell.	Unit Weight (pcf)	Primary Settlement (in.)	Secondary Settlement (in.)
1	INCOMP.	16.5				125.00	0.00	0.00
2	COMP.	19.0	0.037	0.037	0.037	118.00	0.00	0.00
3	INCOMP.	31.0				130.00	0.00	0.00
Total Settlement =							0.00	0.00

N§.	Sublayer		Soil Stresses			Settlement (in.)
	Thick. (ft)	Elev. (ft)	Initial (psf)	Increment (psf)	Max.Past Press. (psf)	
1	INCOMP.					
2	1.90	119.05	2174.60	0.18	2174.60	0.00
3	1.90	117.15	2345.76	0.30	2345.76	0.00
4	1.90	115.25	2451.40	0.45	2451.40	0.00
5	1.90	113.35	2557.04	0.63	2557.04	0.00
6	1.90	111.45	2662.68	0.84	2662.68	0.00
7	1.90	109.55	2768.32	1.07	2768.32	0.00
8	1.90	107.65	2873.96	1.31	2873.96	0.00
9	1.90	105.75	2979.60	1.57	2979.60	0.00
10	1.90	103.85	3085.24	1.83	3085.24	0.00
11	1.90	101.95	3190.88	2.10	3190.88	0.00
12	INCOMP.					
Total Settlement =						0.00 (in.)

RECTANGULAR LOADS

Project Name: North St Culvert, Agawam Project Number : 177018.00
 Client : Woodard-Curran Project Manager: MJO
 Date : 4/6/2023 Computed by : MJO

Increment of stresses obtained using : Boussinesq

Settlement for X = 7.00 (ft) Y = 124.80 (ft)

Footing #	Corner Point P1		Corner Point P2		Load (psf)
	X1(ft)	Y1(ft)	X2(ft)	Y2(ft)	
1	34.50	131.00	49.00	156.00	302.00

Foundation Elev. = 128.50 (ft) Ground Surface Elev.= 136.50 (ft)
 Water table Elev. = 118.00 (ft) Unit weight of Wat. = 62.40 (pcf)

Nº.	Layer Type	Thick. (ft)	Comp. Ratio	Recomp. Ratio	Swell.	Unit Weight (pcf)	Primary Settlement (in.)	Secondary Settlement (in.)
1	INCOMP.	16.5				125.00	0.00	0.00
2	COMP.	19.0	0.037	0.037	0.037	118.00	0.00	0.00
3	INCOMP.	31.0				130.00	0.00	0.00
Total Settlement =							0.00	0.00

N§.	Sublayer		Soil Stresses			Settlement (in.)
	Thick. (ft)	Elev. (ft)	Initial (psf)	Increment (psf)	Max.Past Press. (psf)	
1	INCOMP.					
2	1.90	119.05	2174.60	0.47	2174.60	0.00
3	1.90	117.15	2345.76	0.76	2345.76	0.00
4	1.90	115.25	2451.40	1.11	2451.40	0.00
5	1.90	113.35	2557.04	1.52	2557.04	0.00
6	1.90	111.45	2662.68	1.97	2662.68	0.00
7	1.90	109.55	2768.32	2.44	2768.32	0.00
8	1.90	107.65	2873.96	2.92	2873.96	0.00
9	1.90	105.75	2979.60	3.39	2979.60	0.00
10	1.90	103.85	3085.24	3.83	3085.24	0.00
11	1.90	101.95	3190.88	4.25	3190.88	0.00
12	INCOMP.					
Total Settlement =						0.00 (in.)

RECTANGULAR LOADS

Project Name: North St Culvert, Agawam Project Number : 177018.00
 Client : Woodard-Curran Project Manager: MJO
 Date : 4/6/2023 Computed by : MJO

Increment of stresses obtained using : Boussinesq

Settlement for X = 7.00 (ft) Y = 138.00 (ft)

Footing #	Corner Point P1		Corner Point P2		Load (psf)
	X1(ft)	Y1(ft)	X2(ft)	Y2(ft)	
1	34.50	131.00	49.00	156.00	302.00

Foundation Elev. = 128.50 (ft) Ground Surface Elev.= 136.50 (ft)
 Water table Elev. = 118.00 (ft) Unit weight of Wat. = 62.40 (pcf)

Nº.	Layer Type	Thick. (ft)	Comp. Ratio	Recomp. Ratio	Swell.	Unit Weight (pcf)	Primary Settlement (in.)	Secondary Settlement (in.)
1	INCOMP.	16.5				125.00	0.00	0.00
2	COMP.	19.0	0.037	0.037	0.037	118.00	0.00	0.00
3	INCOMP.	31.0				130.00	0.00	0.00
Total Settlement =							0.00	0.00

N§.	Sublayer		Soil Stresses			Settlement (in.)
	Thick. (ft)	Elev. (ft)	Initial (psf)	Increment (psf)	Max.Past Press. (psf)	
1	INCOMP.					
2	1.90	119.05	2174.60	0.75	2174.60	0.00
3	1.90	117.15	2345.76	1.20	2345.76	0.00
4	1.90	115.25	2451.40	1.74	2451.40	0.00
5	1.90	113.35	2557.04	2.35	2557.04	0.00
6	1.90	111.45	2662.68	2.99	2662.68	0.00
7	1.90	109.55	2768.32	3.65	2768.32	0.00
8	1.90	107.65	2873.96	4.29	2873.96	0.00
9	1.90	105.75	2979.60	4.90	2979.60	0.00
10	1.90	103.85	3085.24	5.46	3085.24	0.00
11	1.90	101.95	3190.88	5.96	3190.88	0.00
12	INCOMP.					
Total Settlement =						0.00 (in.)

RECTANGULAR LOADS

Project Name: North St Culvert, Agawam Project Number : 177018.00
 Client : Woodard-Curran Project Manager: MJO
 Date : 4/6/2023 Computed by : MJO

Increment of stresses obtained using : Boussinesq

Settlement for X = 18.00 (ft) Y = 37.00 (ft)

Footing #	Corner Point P1		Corner Point P2		Load (psf)
	X1(ft)	Y1(ft)	X2(ft)	Y2(ft)	
1	34.50	131.00	49.00	156.00	302.00

Foundation Elev. = 128.50 (ft) Ground Surface Elev.= 136.50 (ft)
 Water table Elev. = 118.00 (ft) Unit weight of Wat. = 62.40 (pcf)

Nº.	Layer Type	Thick. (ft)	Comp. Ratio	Recomp. Ratio	Swell.	Unit Weight (pcf)	Primary Settlement (in.)	Secondary Settlement (in.)
1	INCOMP.	16.5				125.00	0.00	0.00
2	COMP.	19.0	0.037	0.037	0.037	118.00	0.00	0.00
3	INCOMP.	31.0				130.00	0.00	0.00
Total Settlement =							0.00	0.00

N§.	Sublayer		Soil Stresses			Settlement (in.)
	Thick. (ft)	Elev. (ft)	Initial (psf)	Increment (psf)	Max.Past Press. (psf)	
1	INCOMP.					
2	1.90	119.05	2174.60	0.00	2174.60	0.00
3	1.90	117.15	2345.76	0.01	2345.76	0.00
4	1.90	115.25	2451.40	0.01	2451.40	0.00
5	1.90	113.35	2557.04	0.01	2557.04	0.00
6	1.90	111.45	2662.68	0.02	2662.68	0.00
7	1.90	109.55	2768.32	0.02	2768.32	0.00
8	1.90	107.65	2873.96	0.03	2873.96	0.00
9	1.90	105.75	2979.60	0.04	2979.60	0.00
10	1.90	103.85	3085.24	0.05	3085.24	0.00
11	1.90	101.95	3190.88	0.06	3190.88	0.00
12	INCOMP.					
Total Settlement =						0.00 (in.)

RECTANGULAR LOADS

Project Name: North St Culvert, Agawam Project Number : 177018.00
 Client : Woodard-Curran Project Manager: MJO
 Date : 4/6/2023 Computed by : MJO

Increment of stresses obtained using : Boussinesq

Settlement for X = 18.00 (ft) Y = 47.50 (ft)

Footing #	Corner Point P1		Corner Point P2		Load (psf)
	X1(ft)	Y1(ft)	X2(ft)	Y2(ft)	
1	34.50	131.00	49.00	156.00	302.00

Foundation Elev. = 128.50 (ft) Ground Surface Elev.= 136.50 (ft)
 Water table Elev. = 118.00 (ft) Unit weight of Wat. = 62.40 (pcf)

Nº.	Layer Type	Thick. (ft)	Comp. Ratio	Recomp. Ratio	Swell.	Unit Weight (pcf)	Primary Settlement (in.)	Secondary Settlement (in.)
1	INCOMP.	16.5				125.00	0.00	0.00
2	COMP.	19.0	0.037	0.037	0.037	118.00	0.00	0.00
3	INCOMP.	31.0				130.00	0.00	0.00
Total Settlement =							0.00	0.00

N§.	Sublayer		Soil Stresses			Settlement (in.)
	Thick. (ft)	Elev. (ft)	Initial (psf)	Increment (psf)	Max.Past Press. (psf)	
1	INCOMP.					
2	1.90	119.05	2174.60	0.00	2174.60	0.00
3	1.90	117.15	2345.76	0.01	2345.76	0.00
4	1.90	115.25	2451.40	0.01	2451.40	0.00
5	1.90	113.35	2557.04	0.02	2557.04	0.00
6	1.90	111.45	2662.68	0.03	2662.68	0.00
7	1.90	109.55	2768.32	0.04	2768.32	0.00
8	1.90	107.65	2873.96	0.05	2873.96	0.00
9	1.90	105.75	2979.60	0.06	2979.60	0.00
10	1.90	103.85	3085.24	0.08	3085.24	0.00
11	1.90	101.95	3190.88	0.09	3190.88	0.00
12	INCOMP.					
Total Settlement =						0.00 (in.)

RECTANGULAR LOADS

Project Name: North St Culvert, Agawam Project Number : 177018.00
 Client : Woodard-Curran Project Manager: MJO
 Date : 4/6/2023 Computed by : MJO

Increment of stresses obtained using : Boussinesq

Settlement for X = 18.00 (ft) Y = 86.50 (ft)

Footing #	Corner Point P1		Corner Point P2		Load (psf)
	X1(ft)	Y1(ft)	X2(ft)	Y2(ft)	
1	34.50	131.00	49.00	156.00	302.00

Foundation Elev. = 128.50 (ft) Ground Surface Elev.= 136.50 (ft)
 Water table Elev. = 118.00 (ft) Unit weight of Wat. = 62.40 (pcf)

Nº.	Layer Type	Thick. (ft)	Comp. Ratio	Recomp. Ratio	Swell.	Unit Weight (pcf)	Primary Settlement (in.)	Secondary Settlement (in.)
1	INCOMP.	16.5				125.00	0.00	0.00
2	COMP.	19.0	0.037	0.037	0.037	118.00	0.00	0.00
3	INCOMP.	31.0				130.00	0.00	0.00
Total Settlement =							0.00	0.00

N§.	Sublayer		Soil Stresses			Settlement (in.)
	Thick. (ft)	Elev. (ft)	Initial (psf)	Increment (psf)	Max.Past Press. (psf)	
1	INCOMP.					
2	1.90	119.05	2174.60	0.05	2174.60	0.00
3	1.90	117.15	2345.76	0.09	2345.76	0.00
4	1.90	115.25	2451.40	0.14	2451.40	0.00
5	1.90	113.35	2557.04	0.20	2557.04	0.00
6	1.90	111.45	2662.68	0.28	2662.68	0.00
7	1.90	109.55	2768.32	0.36	2768.32	0.00
8	1.90	107.65	2873.96	0.46	2873.96	0.00
9	1.90	105.75	2979.60	0.57	2979.60	0.00
10	1.90	103.85	3085.24	0.68	3085.24	0.00
11	1.90	101.95	3190.88	0.80	3190.88	0.00
12	INCOMP.					
Total Settlement =						0.00 (in.)

RECTANGULAR LOADS

Project Name: North St Culvert, Agawam Project Number : 177018.00
 Client : Woodard-Curran Project Manager: MJO
 Date : 4/6/2023 Computed by : MJO

Increment of stresses obtained using : Boussinesq

Settlement for X = 18.00 (ft) Y = 125.50 (ft)

Footing #	Corner Point P1		Corner Point P2		Load (psf)
	X1(ft)	Y1(ft)	X2(ft)	Y2(ft)	
1	34.50	131.00	49.00	156.00	302.00

Foundation Elev. = 128.50 (ft) Ground Surface Elev.= 136.50 (ft)
 Water table Elev. = 118.00 (ft) Unit weight of Wat. = 62.40 (pcf)

Nº.	Layer Type	Thick. (ft)	Comp. Ratio	Recomp. Ratio	Swell.	Unit Weight (pcf)	Primary Settlement (in.)	Secondary Settlement (in.)
1	INCOMP.	16.5				125.00	0.00	0.00
2	COMP.	19.0	0.037	0.037	0.037	118.00	0.01	0.00
3	INCOMP.	31.0				130.00	0.00	0.00
Total Settlement =							0.01	0.00

N§.	Sublayer		Soil Stresses			Settlement (in.)
	Thick. (ft)	Elev. (ft)	Initial (psf)	Increment (psf)	Max.Past Press. (psf)	
1	INCOMP.					
2	1.90	119.05	2174.60	2.06	2174.60	0.00
3	1.90	117.15	2345.76	3.11	2345.76	0.00
4	1.90	115.25	2451.40	4.26	2451.40	0.00
5	1.90	113.35	2557.04	5.43	2557.04	0.00
6	1.90	111.45	2662.68	6.55	2662.68	0.00
7	1.90	109.55	2768.32	7.58	2768.32	0.00
8	1.90	107.65	2873.96	8.49	2873.96	0.00
9	1.90	105.75	2979.60	9.25	2979.60	0.00
10	1.90	103.85	3085.24	9.87	3085.24	0.00
11	1.90	101.95	3190.88	10.35	3190.88	0.00
12	INCOMP.					
Total Settlement =						0.01 (in.)

RECTANGULAR LOADS

Project Name: North St Culvert, Agawam Project Number : 177018.00
 Client : Woodard-Curran Project Manager: MJO
 Date : 4/6/2023 Computed by : MJO

Increment of stresses obtained using : Boussinesq

Settlement for X = 18.00 (ft) Y = 135.80 (ft)

Footing #	Corner Point P1		Corner Point P2		Load (psf)
	X1(ft)	Y1(ft)	X2(ft)	Y2(ft)	
1	34.50	131.00	49.00	156.00	302.00

Foundation Elev. = 128.50 (ft) Ground Surface Elev.= 136.50 (ft)
 Water table Elev. = 118.00 (ft) Unit weight of Wat. = 62.40 (pcf)

Nº.	Layer Type	Thick. (ft)	Comp. Ratio	Recomp. Ratio	Swell. Ratio	Unit Weight (pcf)	Primary Settlement (in.)	Secondary Settlement (in.)
1	INCOMP.	16.5				125.00	0.00	0.00
2	COMP.	19.0	0.037	0.037	0.037	118.00	0.01	0.00
3	INCOMP.	31.0				130.00	0.00	0.00
Total Settlement =							0.01	0.00

N§.	Sublayer		Soil Stresses			Settlement (in.)
	Thick. (ft)	Elev. (ft)	Initial (psf)	Increment (psf)	Max.Past Press. (psf)	
1	INCOMP.					
2	1.90	119.05	2174.60	3.95	2174.60	0.00
3	1.90	117.15	2345.76	5.78	2345.76	0.00
4	1.90	115.25	2451.40	7.66	2451.40	0.00
5	1.90	113.35	2557.04	9.44	2557.04	0.00
6	1.90	111.45	2662.68	11.02	2662.68	0.00
7	1.90	109.55	2768.32	12.36	2768.32	0.00
8	1.90	107.65	2873.96	13.42	2873.96	0.00
9	1.90	105.75	2979.60	14.23	2979.60	0.00
10	1.90	103.85	3085.24	14.78	3085.24	0.00
11	1.90	101.95	3190.88	15.12	3190.88	0.00
12	INCOMP.					
Total Settlement =						0.01 (in.)

RECTANGULAR LOADS

Project Name: North St Culvert, Agawam Project Number : 177018.00
 Client : Woodard-Curran Project Manager: MJO
 Date : 4/6/2023 Computed by : MJO

Increment of stresses obtained using : Boussinesq

Settlement for X = 18.00 (ft) Y = 145.00 (ft)

Footing #	Corner Point P1		Corner Point P2		Load (psf)
	X1(ft)	Y1(ft)	X2(ft)	Y2(ft)	
1	34.50	131.00	49.00	156.00	302.00

Foundation Elev. = 128.50 (ft) Ground Surface Elev.= 136.50 (ft)
 Water table Elev. = 118.00 (ft) Unit weight of Wat. = 62.40 (pcf)

Nº.	Layer Type	Thick. (ft)	Comp. Ratio	Recomp. Ratio	Swell. Ratio	Unit Weight (pcf)	Primary Settlement (in.)	Secondary Settlement (in.)
1	INCOMP.	16.5				125.00	0.00	0.00
2	COMP.	19.0	0.037	0.037	0.037	118.00	0.02	0.00
3	INCOMP.	31.0				130.00	0.00	0.00
Total Settlement =							0.02	0.00

N§.	Sublayer		Soil Stresses			Settlement (in.)
	Thick. (ft)	Elev. (ft)	Initial (psf)	Increment (psf)	Max.Past Press. (psf)	
1	INCOMP.					
2	1.90	119.05	2174.60	4.53	2174.60	0.00
3	1.90	117.15	2345.76	6.60	2345.76	0.00
4	1.90	115.25	2451.40	8.69	2451.40	0.00
5	1.90	113.35	2557.04	10.65	2557.04	0.00
6	1.90	111.45	2662.68	12.36	2662.68	0.00
7	1.90	109.55	2768.32	13.77	2768.32	0.00
8	1.90	107.65	2873.96	14.87	2873.96	0.00
9	1.90	105.75	2979.60	15.66	2979.60	0.00
10	1.90	103.85	3085.24	16.18	3085.24	0.00
11	1.90	101.95	3190.88	16.47	3190.88	0.00
12	INCOMP.					
Total Settlement =						0.02 (in.)

RECTANGULAR LOADS

Project Name: North St Culvert, Agawam Project Number : 177018.00
 Client : Woodard-Curran Project Manager: MJO
 Date : 4/6/2023 Computed by : MJO

Increment of stresses obtained using : Boussinesq

Settlement for X = 7.00 (ft) Y = 32.00 (ft)

Footing #	Corner Point P1		Corner Point P2		Load (psf)
	X1(ft)	Y1(ft)	X2(ft)	Y2(ft)	
1	29.00	118.50	47.00	131.00	302.00

Foundation Elev. = 128.50 (ft) Ground Surface Elev.= 136.50 (ft)
 Water table Elev. = 118.00 (ft) Unit weight of Wat. = 62.40 (pcf)

Nº.	Layer Type	Thick. (ft)	Comp. Ratio	Recomp. Ratio	Swell. Ratio	Unit Weight (pcf)	Primary Settlement (in.)	Secondary Settlement (in.)
1	INCOMP.	16.5				125.00	0.00	0.00
2	COMP.	19.0	0.037	0.037	0.037	118.00	0.00	0.00
3	INCOMP.	31.0				130.00	0.00	0.00
Total Settlement =							0.00	0.00

N§.	Sublayer		Soil Stresses			Settlement (in.)
	Thick. (ft)	Elev. (ft)	Initial (psf)	Increment (psf)	Max.Past Press. (psf)	
1	INCOMP.					
2	1.90	119.05	2174.60	0.00	2174.60	0.00
3	1.90	117.15	2345.76	0.01	2345.76	0.00
4	1.90	115.25	2451.40	0.01	2451.40	0.00
5	1.90	113.35	2557.04	0.01	2557.04	0.00
6	1.90	111.45	2662.68	0.02	2662.68	0.00
7	1.90	109.55	2768.32	0.02	2768.32	0.00
8	1.90	107.65	2873.96	0.03	2873.96	0.00
9	1.90	105.75	2979.60	0.04	2979.60	0.00
10	1.90	103.85	3085.24	0.05	3085.24	0.00
11	1.90	101.95	3190.88	0.06	3190.88	0.00
12	INCOMP.					
Total Settlement =						0.00 (in.)

RECTANGULAR LOADS

Project Name: North St Culvert, Agawam Project Number : 177018.00
 Client : Woodard-Curran Project Manager: MJO
 Date : 4/6/2023 Computed by : MJO

Increment of stresses obtained using : Boussinesq

Settlement for X = 7.00 (ft) Y = 39.50 (ft)

Footing #	Corner Point P1		Corner Point P2		Load (psf)
	X1(ft)	Y1(ft)	X2(ft)	Y2(ft)	
1	29.00	118.50	47.00	131.00	302.00

Foundation Elev. = 128.50 (ft) Ground Surface Elev.= 136.50 (ft)
 Water table Elev. = 118.00 (ft) Unit weight of Wat. = 62.40 (pcf)

Nº.	Layer Type	Thick. (ft)	Comp. Ratio	Recomp. Ratio	Swell.	Unit Weight (pcf)	Primary Settlement (in.)	Secondary Settlement (in.)
1	INCOMP.	16.5				125.00	0.00	0.00
2	COMP.	19.0	0.037	0.037	0.037	118.00	0.00	0.00
3	INCOMP.	31.0				130.00	0.00	0.00
Total Settlement =							0.00	0.00

N§.	Sublayer		Soil Stresses			Settlement (in.)
	Thick. (ft)	Elev. (ft)	Initial (psf)	Increment (psf)	Max.Past Press. (psf)	
1	INCOMP.					
2	1.90	119.05	2174.60	0.00	2174.60	0.00
3	1.90	117.15	2345.76	0.01	2345.76	0.00
4	1.90	115.25	2451.40	0.01	2451.40	0.00
5	1.90	113.35	2557.04	0.02	2557.04	0.00
6	1.90	111.45	2662.68	0.02	2662.68	0.00
7	1.90	109.55	2768.32	0.03	2768.32	0.00
8	1.90	107.65	2873.96	0.04	2873.96	0.00
9	1.90	105.75	2979.60	0.05	2979.60	0.00
10	1.90	103.85	3085.24	0.07	3085.24	0.00
11	1.90	101.95	3190.88	0.08	3190.88	0.00
12	INCOMP.					
Total Settlement =						0.00 (in.)

RECTANGULAR LOADS

Project Name: North St Culvert, Agawam Project Number : 177018.00
 Client : Woodard-Curran Project Manager: MJO
 Date : 4/6/2023 Computed by : MJO

Increment of stresses obtained using : Boussinesq

Settlement for X = 7.00 (ft) Y = 86.50 (ft)

Footing #	Corner Point P1		Corner Point P2		Load (psf)
	X1(ft)	Y1(ft)	X2(ft)	Y2(ft)	
1	29.00	118.50	47.00	131.00	302.00

Foundation Elev. = 128.50 (ft) Ground Surface Elev.= 136.50 (ft)
 Water table Elev. = 118.00 (ft) Unit weight of Wat. = 62.40 (pcf)

Nº.	Layer Type	Thick. (ft)	Comp. Ratio	Recomp. Ratio	Swell.	Unit Weight (pcf)	Primary Settlement (in.)	Secondary Settlement (in.)
1	INCOMP.	16.5				125.00	0.00	0.00
2	COMP.	19.0	0.037	0.037	0.037	118.00	0.00	0.00
3	INCOMP.	31.0				130.00	0.00	0.00
Total Settlement =							0.00	0.00

N§.	Sublayer		Soil Stresses			Settlement (in.)
	Thick. (ft)	Elev. (ft)	Initial (psf)	Increment (psf)	Max.Past Press. (psf)	
1	INCOMP.					
2	1.90	119.05	2174.60	0.09	2174.60	0.00
3	1.90	117.15	2345.76	0.16	2345.76	0.00
4	1.90	115.25	2451.40	0.24	2451.40	0.00
5	1.90	113.35	2557.04	0.34	2557.04	0.00
6	1.90	111.45	2662.68	0.45	2662.68	0.00
7	1.90	109.55	2768.32	0.58	2768.32	0.00
8	1.90	107.65	2873.96	0.72	2873.96	0.00
9	1.90	105.75	2979.60	0.86	2979.60	0.00
10	1.90	103.85	3085.24	1.01	3085.24	0.00
11	1.90	101.95	3190.88	1.16	3190.88	0.00
12	INCOMP.					
Total Settlement =						0.00 (in.)

RECTANGULAR LOADS

Project Name: North St Culvert, Agawam Project Number : 177018.00
 Client : Woodard-Curran Project Manager: MJO
 Date : 4/6/2023 Computed by : MJO

Increment of stresses obtained using : Boussinesq

Settlement for X = 7.00 (ft) Y = 109.80 (ft)

Footing #	Corner Point P1		Corner Point P2		Load (psf)
	X1(ft)	Y1(ft)	X2(ft)	Y2(ft)	
1	29.00	118.50	47.00	131.00	302.00

Foundation Elev. = 128.50 (ft) Ground Surface Elev.= 136.50 (ft)
 Water table Elev. = 118.00 (ft) Unit weight of Wat. = 62.40 (pcf)

Nº.	Layer Type	Thick. (ft)	Comp. Ratio	Recomp. Ratio	Swell. Ratio	Unit Weight (pcf)	Primary Settlement (in.)	Secondary Settlement (in.)
1	INCOMP.	16.5				125.00	0.00	0.00
2	COMP.	19.0	0.037	0.037	0.037	118.00	0.00	0.00
3	INCOMP.	31.0				130.00	0.00	0.00
Total Settlement =							0.00	0.00

N§.	Sublayer		Soil Stresses			Settlement (in.)
	Thick. (ft)	Elev. (ft)	Initial (psf)	Increment (psf)	Max.Past Press. (psf)	
1	INCOMP.					
2	1.90	119.05	2174.60	0.60	2174.60	0.00
3	1.90	117.15	2345.76	0.95	2345.76	0.00
4	1.90	115.25	2451.40	1.35	2451.40	0.00
5	1.90	113.35	2557.04	1.80	2557.04	0.00
6	1.90	111.45	2662.68	2.27	2662.68	0.00
7	1.90	109.55	2768.32	2.73	2768.32	0.00
8	1.90	107.65	2873.96	3.17	2873.96	0.00
9	1.90	105.75	2979.60	3.58	2979.60	0.00
10	1.90	103.85	3085.24	3.95	3085.24	0.00
11	1.90	101.95	3190.88	4.26	3190.88	0.00
12	INCOMP.					
Total Settlement =						0.00 (in.)

RECTANGULAR LOADS

Project Name: North St Culvert, Agawam Project Number : 177018.00
 Client : Woodard-Curran Project Manager: MJO
 Date : 4/6/2023 Computed by : MJO

Increment of stresses obtained using : Boussinesq

Settlement for X = 7.00 (ft) Y = 124.80 (ft)

Footing #	Corner Point P1		Corner Point P2		Load (psf)
	X1(ft)	Y1(ft)	X2(ft)	Y2(ft)	
1	29.00	118.50	47.00	131.00	302.00

Foundation Elev. = 128.50 (ft) Ground Surface Elev.= 136.50 (ft)
 Water table Elev. = 118.00 (ft) Unit weight of Wat. = 62.40 (pcf)

Nº.	Layer Type	Thick. (ft)	Comp. Ratio	Recomp. Ratio	Swell.	Unit Weight (pcf)	Primary Settlement (in.)	Secondary Settlement (in.)
1	INCOMP.	16.5				125.00	0.00	0.00
2	COMP.	19.0	0.037	0.037	0.037	118.00	0.00	0.00
3	INCOMP.	31.0				130.00	0.00	0.00
Total Settlement =							0.00	0.00

N§.	Sublayer		Soil Stresses			Settlement (in.)
	Thick. (ft)	Elev. (ft)	Initial (psf)	Increment (psf)	Max.Past Press. (psf)	
1	INCOMP.					
2	1.90	119.05	2174.60	1.04	2174.60	0.00
3	1.90	117.15	2345.76	1.61	2345.76	0.00
4	1.90	115.25	2451.40	2.24	2451.40	0.00
5	1.90	113.35	2557.04	2.90	2557.04	0.00
6	1.90	111.45	2662.68	3.55	2662.68	0.00
7	1.90	109.55	2768.32	4.16	2768.32	0.00
8	1.90	107.65	2873.96	4.71	2873.96	0.00
9	1.90	105.75	2979.60	5.19	2979.60	0.00
10	1.90	103.85	3085.24	5.59	3085.24	0.00
11	1.90	101.95	3190.88	5.91	3190.88	0.00
12	INCOMP.					
Total Settlement =						0.00 (in.)

RECTANGULAR LOADS

Project Name: North St Culvert, Agawam Project Number : 177018.00
 Client : Woodard-Curran Project Manager: MJO
 Date : 4/6/2023 Computed by : MJO

Increment of stresses obtained using : Boussinesq

Settlement for X = 7.00 (ft) Y = 138.00 (ft)

Footing #	Corner Point P1		Corner Point P2		Load (psf)
	X1(ft)	Y1(ft)	X2(ft)	Y2(ft)	
1	29.00	118.50	47.00	131.00	302.00

Foundation Elev. = 128.50 (ft) Ground Surface Elev.= 136.50 (ft)
 Water table Elev. = 118.00 (ft) Unit weight of Wat. = 62.40 (pcf)

Nº.	Layer Type	Thick. (ft)	Comp. Ratio	Recomp. Ratio	Swell.	Unit Weight (pcf)	Primary Settlement (in.)	Secondary Settlement (in.)
1	INCOMP.	16.5				125.00	0.00	0.00
2	COMP.	19.0	0.037	0.037	0.037	118.00	0.00	0.00
3	INCOMP.	31.0				130.00	0.00	0.00
Total Settlement =							0.00	0.00

N§.	Sublayer		Soil Stresses			Settlement (in.)
	Thick. (ft)	Elev. (ft)	Initial (psf)	Increment (psf)	Max.Past Press. (psf)	
1	INCOMP.					
2	1.90	119.05	2174.60	0.67	2174.60	0.00
3	1.90	117.15	2345.76	1.05	2345.76	0.00
4	1.90	115.25	2451.40	1.50	2451.40	0.00
5	1.90	113.35	2557.04	1.98	2557.04	0.00
6	1.90	111.45	2662.68	2.48	2662.68	0.00
7	1.90	109.55	2768.32	2.97	2768.32	0.00
8	1.90	107.65	2873.96	3.43	2873.96	0.00
9	1.90	105.75	2979.60	3.86	2979.60	0.00
10	1.90	103.85	3085.24	4.24	3085.24	0.00
11	1.90	101.95	3190.88	4.56	3190.88	0.00
12	INCOMP.					
Total Settlement =						0.00 (in.)

RECTANGULAR LOADS

Project Name: North St Culvert, Agawam Project Number : 177018.00
 Client : Woodard-Curran Project Manager: MJO
 Date : 4/6/2023 Computed by : MJO

Increment of stresses obtained using : Boussinesq

Settlement for X = 18.00 (ft) Y = 37.00 (ft)

Footing #	Corner Point P1		Corner Point P2		Load (psf)
	X1(ft)	Y1(ft)	X2(ft)	Y2(ft)	
1	29.00	118.50	47.00	131.00	302.00

Foundation Elev. = 128.50 (ft) Ground Surface Elev.= 136.50 (ft)
 Water table Elev. = 118.00 (ft) Unit weight of Wat. = 62.40 (pcf)

Nº.	Layer Type	Thick. (ft)	Comp. Ratio	Recomp. Ratio	Swell.	Unit Weight (pcf)	Primary Settlement (in.)	Secondary Settlement (in.)
1	INCOMP.	16.5				125.00	0.00	0.00
2	COMP.	19.0	0.037	0.037	0.037	118.00	0.00	0.00
3	INCOMP.	31.0				130.00	0.00	0.00
Total Settlement =							0.00	0.00

N§.	Sublayer		Soil Stresses			Settlement (in.)
	Thick. (ft)	Elev. (ft)	Initial (psf)	Increment (psf)	Max.Past Press. (psf)	
1	INCOMP.					
2	1.90	119.05	2174.60	0.00	2174.60	0.00
3	1.90	117.15	2345.76	0.01	2345.76	0.00
4	1.90	115.25	2451.40	0.01	2451.40	0.00
5	1.90	113.35	2557.04	0.02	2557.04	0.00
6	1.90	111.45	2662.68	0.03	2662.68	0.00
7	1.90	109.55	2768.32	0.03	2768.32	0.00
8	1.90	107.65	2873.96	0.04	2873.96	0.00
9	1.90	105.75	2979.60	0.06	2979.60	0.00
10	1.90	103.85	3085.24	0.07	3085.24	0.00
11	1.90	101.95	3190.88	0.08	3190.88	0.00
12	INCOMP.					
Total Settlement =						0.00 (in.)

RECTANGULAR LOADS

Project Name: North St Culvert, Agawam Project Number : 177018.00
 Client : Woodard-Curran Project Manager: MJO
 Date : 4/6/2023 Computed by : MJO

Increment of stresses obtained using : Boussinesq

Settlement for X = 18.00 (ft) Y = 47.50 (ft)

Footing #	Corner Point P1		Corner Point P2		Load (psf)
	X1(ft)	Y1(ft)	X2(ft)	Y2(ft)	
1	29.00	118.50	47.00	131.00	302.00

Foundation Elev. = 128.50 (ft) Ground Surface Elev.= 136.50 (ft)
 Water table Elev. = 118.00 (ft) Unit weight of Wat. = 62.40 (pcf)

Nº.	Layer Type	Thick. (ft)	Comp. Ratio	Recomp. Ratio	Swell.	Unit Weight (pcf)	Primary Settlement (in.)	Secondary Settlement (in.)
1	INCOMP.	16.5				125.00	0.00	0.00
2	COMP.	19.0	0.037	0.037	0.037	118.00	0.00	0.00
3	INCOMP.	31.0				130.00	0.00	0.00
Total Settlement =							0.00	0.00

N§.	Sublayer		Soil Stresses			Settlement (in.)
	Thick. (ft)	Elev. (ft)	Initial (psf)	Increment (psf)	Max.Past Press. (psf)	
1	INCOMP.					
2	1.90	119.05	2174.60	0.01	2174.60	0.00
3	1.90	117.15	2345.76	0.01	2345.76	0.00
4	1.90	115.25	2451.40	0.02	2451.40	0.00
5	1.90	113.35	2557.04	0.03	2557.04	0.00
6	1.90	111.45	2662.68	0.05	2662.68	0.00
7	1.90	109.55	2768.32	0.06	2768.32	0.00
8	1.90	107.65	2873.96	0.08	2873.96	0.00
9	1.90	105.75	2979.60	0.10	2979.60	0.00
10	1.90	103.85	3085.24	0.12	3085.24	0.00
11	1.90	101.95	3190.88	0.15	3190.88	0.00
12	INCOMP.					
Total Settlement =						0.00 (in.)

RECTANGULAR LOADS

Project Name: North St Culvert, Agawam Project Number : 177018.00
 Client : Woodard-Curran Project Manager: MJO
 Date : 4/6/2023 Computed by : MJO

Increment of stresses obtained using : Boussinesq

Settlement for X = 18.00 (ft) Y = 86.50 (ft)

Footing #	Corner Point P1		Corner Point P2		Load (psf)
	X1(ft)	Y1(ft)	X2(ft)	Y2(ft)	
1	29.00	118.50	47.00	131.00	302.00

Foundation Elev. = 128.50 (ft) Ground Surface Elev.= 136.50 (ft)
 Water table Elev. = 118.00 (ft) Unit weight of Wat. = 62.40 (pcf)

Nº.	Layer Type	Thick. (ft)	Comp. Ratio	Recomp. Ratio	Swell. Ratio	Unit Weight (pcf)	Primary Settlement (in.)	Secondary Settlement (in.)
1	INCOMP.	16.5				125.00	0.00	0.00
2	COMP.	19.0	0.037	0.037	0.037	118.00	0.00	0.00
3	INCOMP.	31.0				130.00	0.00	0.00
Total Settlement =							0.00	0.00

N§.	Sublayer		Soil Stresses			Settlement (in.)
	Thick. (ft)	Elev. (ft)	Initial (psf)	Increment (psf)	Max.Past Press. (psf)	
1	INCOMP.					
2	1.90	119.05	2174.60	0.18	2174.60	0.00
3	1.90	117.15	2345.76	0.29	2345.76	0.00
4	1.90	115.25	2451.40	0.44	2451.40	0.00
5	1.90	113.35	2557.04	0.61	2557.04	0.00
6	1.90	111.45	2662.68	0.80	2662.68	0.00
7	1.90	109.55	2768.32	1.01	2768.32	0.00
8	1.90	107.65	2873.96	1.23	2873.96	0.00
9	1.90	105.75	2979.60	1.45	2979.60	0.00
10	1.90	103.85	3085.24	1.68	3085.24	0.00
11	1.90	101.95	3190.88	1.89	3190.88	0.00
12	INCOMP.					
Total Settlement =						0.00 (in.)

RECTANGULAR LOADS

Project Name: North St Culvert, Agawam Project Number : 177018.00
 Client : Woodard-Curran Project Manager: MJO
 Date : 4/6/2023 Computed by : MJO

Increment of stresses obtained using : Boussinesq

Settlement for X = 18.00 (ft) Y = 125.50 (ft)

Footing #	Corner Point P1		Corner Point P2		Load (psf)
	X1(ft)	Y1(ft)	X2(ft)	Y2(ft)	
1	29.00	118.50	47.00	131.00	302.00

Foundation Elev. = 128.50 (ft) Ground Surface Elev.= 136.50 (ft)
 Water table Elev. = 118.00 (ft) Unit weight of Wat. = 62.40 (pcf)

Nº.	Layer Type	Thick. (ft)	Comp. Ratio	Recomp. Ratio	Swell. Ratio	Unit Weight (pcf)	Primary Settlement (in.)	Secondary Settlement (in.)
1	INCOMP.	16.5				125.00	0.00	0.00
2	COMP.	19.0	0.037	0.037	0.037	118.00	0.02	0.00
3	INCOMP.	31.0				130.00	0.00	0.00
Total Settlement =							0.02	0.00

N§.	Sublayer		Soil Stresses			Settlement (in.)
	Thick. (ft)	Elev. (ft)	Initial (psf)	Increment (psf)	Max.Past Press. (psf)	
1	INCOMP.					
2	1.90	119.05	2174.60	8.81	2174.60	0.00
3	1.90	117.15	2345.76	11.39	2345.76	0.00
4	1.90	115.25	2451.40	13.45	2451.40	0.00
5	1.90	113.35	2557.04	14.94	2557.04	0.00
6	1.90	111.45	2662.68	15.90	2662.68	0.00
7	1.90	109.55	2768.32	16.41	2768.32	0.00
8	1.90	107.65	2873.96	16.58	2873.96	0.00
9	1.90	105.75	2979.60	16.48	2979.60	0.00
10	1.90	103.85	3085.24	16.19	3085.24	0.00
11	1.90	101.95	3190.88	15.75	3190.88	0.00
12	INCOMP.					
Total Settlement =						0.02 (in.)

RECTANGULAR LOADS

Project Name: North St Culvert, Agawam Project Number : 177018.00
 Client : Woodard-Curran Project Manager: MJO
 Date : 4/6/2023 Computed by : MJO

Increment of stresses obtained using : Boussinesq

Settlement for X = 18.00 (ft) Y = 135.80 (ft)

Footing #	Corner Point P1		Corner Point P2		Load (psf)
	X1(ft)	Y1(ft)	X2(ft)	Y2(ft)	
1	29.00	118.50	47.00	131.00	302.00

Foundation Elev. = 128.50 (ft) Ground Surface Elev.= 136.50 (ft)
 Water table Elev. = 118.00 (ft) Unit weight of Wat. = 62.40 (pcf)

Nº.	Layer Type	Thick. (ft)	Comp. Ratio	Recomp. Ratio	Swell.	Unit Weight (pcf)	Primary Settlement (in.)	Secondary Settlement (in.)
1	INCOMP.	16.5				125.00	0.00	0.00
2	COMP.	19.0	0.037	0.037	0.037	118.00	0.01	0.00
3	INCOMP.	31.0				130.00	0.00	0.00
Total Settlement =							0.01	0.00

N§.	Sublayer		Soil Stresses			Settlement (in.)
	Thick. (ft)	Elev. (ft)	Initial (psf)	Increment (psf)	Max.Past Press. (psf)	
1	INCOMP.					
2	1.90	119.05	2174.60	4.55	2174.60	0.00
3	1.90	117.15	2345.76	6.29	2345.76	0.00
4	1.90	115.25	2451.40	7.90	2451.40	0.00
5	1.90	113.35	2557.04	9.28	2557.04	0.00
6	1.90	111.45	2662.68	10.37	2662.68	0.00
7	1.90	109.55	2768.32	11.18	2768.32	0.00
8	1.90	107.65	2873.96	11.73	2873.96	0.00
9	1.90	105.75	2979.60	12.06	2979.60	0.00
10	1.90	103.85	3085.24	12.19	3085.24	0.00
11	1.90	101.95	3190.88	12.17	3190.88	0.00
12	INCOMP.					
Total Settlement =						0.01 (in.)

RECTANGULAR LOADS

Project Name: North St Culvert, Agawam Project Number : 177018.00
 Client : Woodard-Curran Project Manager: MJO
 Date : 4/6/2023 Computed by : MJO

Increment of stresses obtained using : Boussinesq

Settlement for X = 18.00 (ft) Y = 145.00 (ft)

Footing #	Corner Point P1		Corner Point P2		Load (psf)
	X1(ft)	Y1(ft)	X2(ft)	Y2(ft)	
1	29.00	118.50	47.00	131.00	302.00

Foundation Elev. = 128.50 (ft) Ground Surface Elev.= 136.50 (ft)
 Water table Elev. = 118.00 (ft) Unit weight of Wat. = 62.40 (pcf)

Nº.	Layer Type	Thick. (ft)	Comp. Ratio	Recomp. Ratio	Swell. Ratio	Unit Weight (pcf)	Primary Settlement (in.)	Secondary Settlement (in.)
1	INCOMP.	16.5				125.00	0.00	0.00
2	COMP.	19.0	0.037	0.037	0.037	118.00	0.01	0.00
3	INCOMP.	31.0				130.00	0.00	0.00
Total Settlement =							0.01	0.00

N§.	Sublayer		Soil Stresses			Settlement (in.)
	Thick. (ft)	Elev. (ft)	Initial (psf)	Increment (psf)	Max.Past Press. (psf)	
1	INCOMP.					
2	1.90	119.05	2174.60	1.46	2174.60	0.00
3	1.90	117.15	2345.76	2.20	2345.76	0.00
4	1.90	115.25	2451.40	3.01	2451.40	0.00
5	1.90	113.35	2557.04	3.84	2557.04	0.00
6	1.90	111.45	2662.68	4.62	2662.68	0.00
7	1.90	109.55	2768.32	5.33	2768.32	0.00
8	1.90	107.65	2873.96	5.95	2873.96	0.00
9	1.90	105.75	2979.60	6.47	2979.60	0.00
10	1.90	103.85	3085.24	6.87	3085.24	0.00
11	1.90	101.95	3190.88	7.18	3190.88	0.00
12	INCOMP.					
Total Settlement =						0.01 (in.)

RECTANGULAR LOADS

Project Name: North St Culvert, Agawam Project Number : 177018.00
 Client : Woodard-Curran Project Manager: MJO
 Date : 4/6/2023 Computed by : MJO

Increment of stresses obtained using : Boussinesq

Settlement for X = 7.00 (ft) Y = 32.00 (ft)

Footing #	Corner Point P1		Corner Point P2		Load (psf)
	X1(ft)	Y1(ft)	X2(ft)	Y2(ft)	
1	-11.00	101.00	7.00	118.50	181.00

Foundation Elev. = 131.50 (ft) Ground Surface Elev.= 136.50 (ft)
 Water table Elev. = 118.00 (ft) Unit weight of Wat. = 62.40 (pcf)

Nº.	Layer Type	Thick. (ft)	Comp. Ratio	Recomp. Ratio	Swell.	Unit Weight (pcf)	Primary Settlement (in.)	Secondary Settlement (in.)
1	INCOMP.	16.5				125.00	0.00	0.00
2	COMP.	19.0	0.037	0.037	0.037	118.00	0.00	0.00
3	INCOMP.	31.0				130.00	0.00	0.00
Total Settlement =							0.00	0.00

N§.	Sublayer		Soil Stresses			Settlement (in.)
	Thick. (ft)	Elev. (ft)	Initial (psf)	Increment (psf)	Max.Past Press. (psf)	
1	INCOMP.					
2	1.90	119.05	2174.60	0.02	2174.60	0.00
3	1.90	117.15	2345.76	0.03	2345.76	0.00
4	1.90	115.25	2451.40	0.04	2451.40	0.00
5	1.90	113.35	2557.04	0.05	2557.04	0.00
6	1.90	111.45	2662.68	0.07	2662.68	0.00
7	1.90	109.55	2768.32	0.08	2768.32	0.00
8	1.90	107.65	2873.96	0.10	2873.96	0.00
9	1.90	105.75	2979.60	0.13	2979.60	0.00
10	1.90	103.85	3085.24	0.15	3085.24	0.00
11	1.90	101.95	3190.88	0.18	3190.88	0.00
12	INCOMP.					
Total Settlement =						0.00 (in.)

RECTANGULAR LOADS

Project Name: North St Culvert, Agawam Project Number : 177018.00
 Client : Woodard-Curran Project Manager: MJO
 Date : 4/6/2023 Computed by : MJO

Increment of stresses obtained using : Boussinesq

Settlement for X = 7.00 (ft) Y = 39.50 (ft)

Footing #	Corner Point P1		Corner Point P2		Load (psf)
	X1(ft)	Y1(ft)	X2(ft)	Y2(ft)	
1	-11.00	101.00	7.00	118.50	181.00

Foundation Elev. = 131.50 (ft) Ground Surface Elev.= 136.50 (ft)
 Water table Elev. = 118.00 (ft) Unit weight of Wat. = 62.40 (pcf)

Nº.	Layer Type	Thick. (ft)	Comp. Ratio	Recomp. Ratio	Swell.	Unit Weight (pcf)	Primary Settlement (in.)	Secondary Settlement (in.)
1	INCOMP.	16.5				125.00	0.00	0.00
2	COMP.	19.0	0.037	0.037	0.037	118.00	0.00	0.00
3	INCOMP.	31.0				130.00	0.00	0.00
Total Settlement =							0.00	0.00

N§.	Sublayer		Soil Stresses			Settlement (in.)
	Thick. (ft)	Elev. (ft)	Initial (psf)	Increment (psf)	Max.Past Press. (psf)	
1	INCOMP.					
2	1.90	119.05	2174.60	0.03	2174.60	0.00
3	1.90	117.15	2345.76	0.04	2345.76	0.00
4	1.90	115.25	2451.40	0.06	2451.40	0.00
5	1.90	113.35	2557.04	0.08	2557.04	0.00
6	1.90	111.45	2662.68	0.11	2662.68	0.00
7	1.90	109.55	2768.32	0.14	2768.32	0.00
8	1.90	107.65	2873.96	0.17	2873.96	0.00
9	1.90	105.75	2979.60	0.20	2979.60	0.00
10	1.90	103.85	3085.24	0.24	3085.24	0.00
11	1.90	101.95	3190.88	0.28	3190.88	0.00
12	INCOMP.					
Total Settlement =						0.00 (in.)

RECTANGULAR LOADS

Project Name: North St Culvert, Agawam Project Number : 177018.00
 Client : Woodard-Curran Project Manager: MJO
 Date : 4/6/2023 Computed by : MJO

Increment of stresses obtained using : Boussinesq

Settlement for X = 7.00 (ft) Y = 86.50 (ft)

Footing #	Corner Point P1		Corner Point P2		Load (psf)
	X1(ft)	Y1(ft)	X2(ft)	Y2(ft)	
1	-11.00	101.00	7.00	118.50	181.00

Foundation Elev. = 131.50 (ft) Ground Surface Elev.= 136.50 (ft)
 Water table Elev. = 118.00 (ft) Unit weight of Wat. = 62.40 (pcf)

Nº.	Layer Type	Thick. (ft)	Comp. Ratio	Recomp. Ratio	Swell.	Unit Weight (pcf)	Primary Settlement (in.)	Secondary Settlement (in.)
1	INCOMP.	16.5				125.00	0.00	0.00
2	COMP.	19.0	0.037	0.037	0.037	118.00	0.01	0.00
3	INCOMP.	31.0				130.00	0.00	0.00
Total Settlement =							0.01	0.00

N§.	Sublayer		Soil Stresses			Settlement (in.)
	Thick. (ft)	Elev. (ft)	Initial (psf)	Increment (psf)	Max.Past Press. (psf)	
1	INCOMP.					
2	1.90	119.05	2174.60	4.19	2174.60	0.00
3	1.90	117.15	2345.76	5.21	2345.76	0.00
4	1.90	115.25	2451.40	6.11	2451.40	0.00
5	1.90	113.35	2557.04	6.86	2557.04	0.00
6	1.90	111.45	2662.68	7.45	2662.68	0.00
7	1.90	109.55	2768.32	7.88	2768.32	0.00
8	1.90	107.65	2873.96	8.17	2873.96	0.00
9	1.90	105.75	2979.60	8.34	2979.60	0.00
10	1.90	103.85	3085.24	8.41	3085.24	0.00
11	1.90	101.95	3190.88	8.40	3190.88	0.00
12	INCOMP.					
Total Settlement =						0.01 (in.)

RECTANGULAR LOADS

Project Name: North St Culvert, Agawam Project Number : 177018.00
 Client : Woodard-Curran Project Manager: MJO
 Date : 4/6/2023 Computed by : MJO

Increment of stresses obtained using : Boussinesq

Settlement for X = 7.00 (ft) Y = 109.80 (ft)

Footing #	Corner Point P1		Corner Point P2		Load (psf)
	X1(ft)	Y1(ft)	X2(ft)	Y2(ft)	
1	-11.00	101.00	7.00	118.50	181.00

Foundation Elev. = 131.50 (ft) Ground Surface Elev.= 136.50 (ft)
 Water table Elev. = 118.00 (ft) Unit weight of Wat. = 62.40 (pcf)

Nº.	Layer Type	Thick. (ft)	Comp. Ratio	Recomp. Ratio	Swell.	Unit Weight (pcf)	Primary Settlement (in.)	Secondary Settlement (in.)
1	INCOMP.	16.5				125.00	0.00	0.00
2	COMP.	19.0	0.037	0.037	0.037	118.00	0.05	0.00
3	INCOMP.	31.0				130.00	0.00	0.00
Total Settlement =							0.05	0.00

N§.	Sublayer		Soil Stresses			Settlement (in.)
	Thick. (ft)	Elev. (ft)	Initial (psf)	Increment (psf)	Max.Past Press. (psf)	
1	INCOMP.					
2	1.90	119.05	2174.60	59.08	2174.60	0.01
3	1.90	117.15	2345.76	52.85	2345.76	0.01
4	1.90	115.25	2451.40	47.24	2451.40	0.01
5	1.90	113.35	2557.04	42.25	2557.04	0.01
6	1.90	111.45	2662.68	37.85	2662.68	0.01
7	1.90	109.55	2768.32	33.99	2768.32	0.00
8	1.90	107.65	2873.96	30.60	2873.96	0.00
9	1.90	105.75	2979.60	27.63	2979.60	0.00
10	1.90	103.85	3085.24	25.02	3085.24	0.00
11	1.90	101.95	3190.88	22.73	3190.88	0.00
12	INCOMP.					
Total Settlement =						0.05 (in.)

RECTANGULAR LOADS

Project Name: North St Culvert, Agawam Project Number : 177018.00
 Client : Woodard-Curran Project Manager: MJO
 Date : 4/6/2023 Computed by : MJO

Increment of stresses obtained using : Boussinesq

Settlement for X = 7.00 (ft) Y = 124.80 (ft)

Footing #	Corner Point P1		Corner Point P2		Load (psf)
	X1(ft)	Y1(ft)	X2(ft)	Y2(ft)	
1	-11.00	101.00	7.00	118.50	181.00

Foundation Elev. = 131.50 (ft) Ground Surface Elev.= 136.50 (ft)
 Water table Elev. = 118.00 (ft) Unit weight of Wat. = 62.40 (pcf)

Nº.	Layer Type	Thick. (ft)	Comp. Ratio	Recomp. Ratio	Swell.	Unit Weight (pcf)	Primary Settlement (in.)	Secondary Settlement (in.)
1	INCOMP.	16.5				125.00	0.00	0.00
2	COMP.	19.0	0.037	0.037	0.037	118.00	0.02	0.00
3	INCOMP.	31.0				130.00	0.00	0.00
Total Settlement =							0.02	0.00

N§.	Sublayer		Soil Stresses			Settlement (in.)
	Thick. (ft)	Elev. (ft)	Initial (psf)	Increment (psf)	Max.Past Press. (psf)	
1	INCOMP.					
2	1.90	119.05	2174.60	16.17	2174.60	0.00
3	1.90	117.15	2345.76	17.24	2345.76	0.00
4	1.90	115.25	2451.40	17.75	2451.40	0.00
5	1.90	113.35	2557.04	17.83	2557.04	0.00
6	1.90	111.45	2662.68	17.61	2662.68	0.00
7	1.90	109.55	2768.32	17.17	2768.32	0.00
8	1.90	107.65	2873.96	16.58	2873.96	0.00
9	1.90	105.75	2979.60	15.90	2979.60	0.00
10	1.90	103.85	3085.24	15.18	3085.24	0.00
11	1.90	101.95	3190.88	14.43	3190.88	0.00
12	INCOMP.					
Total Settlement =						0.02 (in.)

RECTANGULAR LOADS

Project Name: North St Culvert, Agawam Project Number : 177018.00
 Client : Woodard-Curran Project Manager: MJO
 Date : 4/6/2023 Computed by : MJO

Increment of stresses obtained using : Boussinesq

Settlement for X = 7.00 (ft) Y = 138.00 (ft)

Footing #	Corner Point P1		Corner Point P2		Load (psf)
	X1(ft)	Y1(ft)	X2(ft)	Y2(ft)	
1	-11.00	101.00	7.00	118.50	181.00

Foundation Elev. = 131.50 (ft) Ground Surface Elev.= 136.50 (ft)
 Water table Elev. = 118.00 (ft) Unit weight of Wat. = 62.40 (pcf)

Nº.	Layer Type	Thick. (ft)	Comp. Ratio	Recomp. Ratio	Swell.	Unit Weight (pcf)	Primary Settlement (in.)	Secondary Settlement (in.)
1	INCOMP.	16.5				125.00	0.00	0.00
2	COMP.	19.0	0.037	0.037	0.037	118.00	0.01	0.00
3	INCOMP.	31.0				130.00	0.00	0.00
Total Settlement =							0.01	0.00

N§.	Sublayer		Soil Stresses			Settlement (in.)
	Thick. (ft)	Elev. (ft)	Initial (psf)	Increment (psf)	Max.Past Press. (psf)	
1	INCOMP.					
2	1.90	119.05	2174.60	1.94	2174.60	0.00
3	1.90	117.15	2345.76	2.56	2345.76	0.00
4	1.90	115.25	2451.40	3.17	2451.40	0.00
5	1.90	113.35	2557.04	3.75	2557.04	0.00
6	1.90	111.45	2662.68	4.26	2662.68	0.00
7	1.90	109.55	2768.32	4.71	2768.32	0.00
8	1.90	107.65	2873.96	5.07	2873.96	0.00
9	1.90	105.75	2979.60	5.37	2979.60	0.00
10	1.90	103.85	3085.24	5.59	3085.24	0.00
11	1.90	101.95	3190.88	5.74	3190.88	0.00
12	INCOMP.					
Total Settlement =						0.01 (in.)

RECTANGULAR LOADS

Project Name: North St Culvert, Agawam Project Number : 177018.00
 Client : Woodard-Curran Project Manager: MJO
 Date : 4/6/2023 Computed by : MJO

Increment of stresses obtained using : Boussinesq

Settlement for X = 18.00 (ft) Y = 37.00 (ft)

Footing #	Corner Point P1		Corner Point P2		Load (psf)
	X1(ft)	Y1(ft)	X2(ft)	Y2(ft)	
1	-11.00	101.00	7.00	118.50	181.00

Foundation Elev. = 131.50 (ft) Ground Surface Elev.= 136.50 (ft)
 Water table Elev. = 118.00 (ft) Unit weight of Wat. = 62.40 (pcf)

Nº.	Layer Type	Thick. (ft)	Comp. Ratio	Recomp. Ratio	Swell.	Unit Weight (pcf)	Primary Settlement (in.)	Secondary Settlement (in.)
1	INCOMP.	16.5				125.00	0.00	0.00
2	COMP.	19.0	0.037	0.037	0.037	118.00	0.00	0.00
3	INCOMP.	31.0				130.00	0.00	0.00
Total Settlement =							0.00	0.00

N§.	Sublayer		Soil Stresses			Settlement (in.)
	Thick. (ft)	Elev. (ft)	Initial (psf)	Increment (psf)	Max.Past Press. (psf)	
1	INCOMP.					
2	1.90	119.05	2174.60	0.02	2174.60	0.00
3	1.90	117.15	2345.76	0.03	2345.76	0.00
4	1.90	115.25	2451.40	0.04	2451.40	0.00
5	1.90	113.35	2557.04	0.06	2557.04	0.00
6	1.90	111.45	2662.68	0.08	2662.68	0.00
7	1.90	109.55	2768.32	0.10	2768.32	0.00
8	1.90	107.65	2873.96	0.12	2873.96	0.00
9	1.90	105.75	2979.60	0.15	2979.60	0.00
10	1.90	103.85	3085.24	0.18	3085.24	0.00
11	1.90	101.95	3190.88	0.21	3190.88	0.00
12	INCOMP.					
Total Settlement =						0.00 (in.)

RECTANGULAR LOADS

Project Name: North St Culvert, Agawam Project Number : 177018.00
 Client : Woodard-Curran Project Manager: MJO
 Date : 4/6/2023 Computed by : MJO

Increment of stresses obtained using : Boussinesq

Settlement for X = 18.00 (ft) Y = 47.50 (ft)

Footing #	Corner Point P1		Corner Point P2		Load (psf)
	X1(ft)	Y1(ft)	X2(ft)	Y2(ft)	
1	-11.00	101.00	7.00	118.50	181.00

Foundation Elev. = 131.50 (ft) Ground Surface Elev.= 136.50 (ft)
 Water table Elev. = 118.00 (ft) Unit weight of Wat. = 62.40 (pcf)

Nº.	Layer Type	Thick. (ft)	Comp. Ratio	Recomp. Ratio	Swell.	Unit Weight (pcf)	Primary Settlement (in.)	Secondary Settlement (in.)
1	INCOMP.	16.5				125.00	0.00	0.00
2	COMP.	19.0	0.037	0.037	0.037	118.00	0.00	0.00
3	INCOMP.	31.0				130.00	0.00	0.00
Total Settlement =							0.00	0.00

N§.	Sublayer		Soil Stresses			Settlement (in.)
	Thick. (ft)	Elev. (ft)	Initial (psf)	Increment (psf)	Max.Past Press. (psf)	
1	INCOMP.					
2	1.90	119.05	2174.60	0.04	2174.60	0.00
3	1.90	117.15	2345.76	0.06	2345.76	0.00
4	1.90	115.25	2451.40	0.09	2451.40	0.00
5	1.90	113.35	2557.04	0.12	2557.04	0.00
6	1.90	111.45	2662.68	0.16	2662.68	0.00
7	1.90	109.55	2768.32	0.20	2768.32	0.00
8	1.90	107.65	2873.96	0.24	2873.96	0.00
9	1.90	105.75	2979.60	0.29	2979.60	0.00
10	1.90	103.85	3085.24	0.34	3085.24	0.00
11	1.90	101.95	3190.88	0.39	3190.88	0.00
12	INCOMP.					
Total Settlement =						0.00 (in.)

RECTANGULAR LOADS

Project Name: North St Culvert, Agawam Project Number : 177018.00
 Client : Woodard-Curran Project Manager: MJO
 Date : 4/6/2023 Computed by : MJO

Increment of stresses obtained using : Boussinesq

Settlement for X = 18.00 (ft) Y = 86.50 (ft)

Footing #	Corner Point P1		Corner Point P2		Load (psf)
	X1(ft)	Y1(ft)	X2(ft)	Y2(ft)	
1	-11.00	101.00	7.00	118.50	181.00

Foundation Elev. = 131.50 (ft) Ground Surface Elev.= 136.50 (ft)
 Water table Elev. = 118.00 (ft) Unit weight of Wat. = 62.40 (pcf)

Nº.	Layer Type	Thick. (ft)	Comp. Ratio	Recomp. Ratio	Swell.	Unit Weight (pcf)	Primary Settlement (in.)	Secondary Settlement (in.)
1	INCOMP.	16.5				125.00	0.00	0.00
2	COMP.	19.0	0.037	0.037	0.037	118.00	0.01	0.00
3	INCOMP.	31.0				130.00	0.00	0.00
Total Settlement =							0.01	0.00

N§.	Sublayer		Soil Stresses			Settlement (in.)
	Thick. (ft)	Elev. (ft)	Initial (psf)	Increment (psf)	Max.Past Press. (psf)	
1	INCOMP.					
2	1.90	119.05	2174.60	1.71	2174.60	0.00
3	1.90	117.15	2345.76	2.27	2345.76	0.00
4	1.90	115.25	2451.40	2.83	2451.40	0.00
5	1.90	113.35	2557.04	3.36	2557.04	0.00
6	1.90	111.45	2662.68	3.84	2662.68	0.00
7	1.90	109.55	2768.32	4.26	2768.32	0.00
8	1.90	107.65	2873.96	4.62	2873.96	0.00
9	1.90	105.75	2979.60	4.91	2979.60	0.00
10	1.90	103.85	3085.24	5.14	3085.24	0.00
11	1.90	101.95	3190.88	5.31	3190.88	0.00
12	INCOMP.					
Total Settlement =						0.01 (in.)

RECTANGULAR LOADS

Project Name: North St Culvert, Agawam Project Number : 177018.00
 Client : Woodard-Curran Project Manager: MJO
 Date : 4/6/2023 Computed by : MJO

Increment of stresses obtained using : Boussinesq

Settlement for X = 18.00 (ft) Y = 125.50 (ft)

Footing #	Corner Point P1		Corner Point P2		Load (psf)
	X1(ft)	Y1(ft)	X2(ft)	Y2(ft)	
1	-11.00	101.00	7.00	118.50	181.00

Foundation Elev. = 131.50 (ft) Ground Surface Elev.= 136.50 (ft)
 Water table Elev. = 118.00 (ft) Unit weight of Wat. = 62.40 (pcf)

Nº.	Layer Type	Thick. (ft)	Comp. Ratio	Recomp. Ratio	Swell.	Unit Weight (pcf)	Primary Settlement (in.)	Secondary Settlement (in.)
1	INCOMP.	16.5				125.00	0.00	0.00
2	COMP.	19.0	0.037	0.037	0.037	118.00	0.01	0.00
3	INCOMP.	31.0				130.00	0.00	0.00
Total Settlement =							0.01	0.00

N§.	Sublayer		Soil Stresses			Settlement (in.)
	Thick. (ft)	Elev. (ft)	Initial (psf)	Increment (psf)	Max.Past Press. (psf)	
1	INCOMP.					
2	1.90	119.05	2174.60	3.98	2174.60	0.00
3	1.90	117.15	2345.76	4.95	2345.76	0.00
4	1.90	115.25	2451.40	5.81	2451.40	0.00
5	1.90	113.35	2557.04	6.53	2557.04	0.00
6	1.90	111.45	2662.68	7.10	2662.68	0.00
7	1.90	109.55	2768.32	7.53	2768.32	0.00
8	1.90	107.65	2873.96	7.83	2873.96	0.00
9	1.90	105.75	2979.60	8.01	2979.60	0.00
10	1.90	103.85	3085.24	8.09	3085.24	0.00
11	1.90	101.95	3190.88	8.10	3190.88	0.00
12	INCOMP.					
Total Settlement =						0.01 (in.)

RECTANGULAR LOADS

Project Name: North St Culvert, Agawam Project Number : 177018.00
 Client : Woodard-Curran Project Manager: MJO
 Date : 4/6/2023 Computed by : MJO

Increment of stresses obtained using : Boussinesq

Settlement for X = 18.00 (ft) Y = 135.80 (ft)

Footing #	Corner Point P1		Corner Point P2		Load (psf)
	X1(ft)	Y1(ft)	X2(ft)	Y2(ft)	
1	-11.00	101.00	7.00	118.50	181.00

Foundation Elev. = 131.50 (ft) Ground Surface Elev.= 136.50 (ft)
 Water table Elev. = 118.00 (ft) Unit weight of Wat. = 62.40 (pcf)

Nº.	Layer Type	Thick. (ft)	Comp. Ratio	Recomp. Ratio	Swell.	Unit Weight (pcf)	Primary Settlement (in.)	Secondary Settlement (in.)
1	INCOMP.	16.5				125.00	0.00	0.00
2	COMP.	19.0	0.037	0.037	0.037	118.00	0.00	0.00
3	INCOMP.	31.0				130.00	0.00	0.00
Total Settlement =							0.00	0.00

N§.	Sublayer		Soil Stresses			Settlement (in.)
	Thick. (ft)	Elev. (ft)	Initial (psf)	Increment (psf)	Max.Past Press. (psf)	
1	INCOMP.					
2	1.90	119.05	2174.60	1.24	2174.60	0.00
3	1.90	117.15	2345.76	1.68	2345.76	0.00
4	1.90	115.25	2451.40	2.13	2451.40	0.00
5	1.90	113.35	2557.04	2.57	2557.04	0.00
6	1.90	111.45	2662.68	2.99	2662.68	0.00
7	1.90	109.55	2768.32	3.37	2768.32	0.00
8	1.90	107.65	2873.96	3.71	2873.96	0.00
9	1.90	105.75	2979.60	4.00	2979.60	0.00
10	1.90	103.85	3085.24	4.24	3085.24	0.00
11	1.90	101.95	3190.88	4.44	3190.88	0.00
12	INCOMP.					
Total Settlement =						0.00 (in.)

RECTANGULAR LOADS

Project Name: North St Culvert, Agawam Project Number : 177018.00
 Client : Woodard-Curran Project Manager: MJO
 Date : 4/6/2023 Computed by : MJO

Increment of stresses obtained using : Boussinesq

Settlement for X = 18.00 (ft) Y = 145.00 (ft)

Footing #	Corner Point P1		Corner Point P2		Load (psf)
	X1(ft)	Y1(ft)	X2(ft)	Y2(ft)	
1	-11.00	101.00	7.00	118.50	181.00

Foundation Elev. = 131.50 (ft) Ground Surface Elev.= 136.50 (ft)
 Water table Elev. = 118.00 (ft) Unit weight of Wat. = 62.40 (pcf)

Nº.	Layer Type	Thick. (ft)	Comp. Ratio	Recomp. Ratio	Swell.	Unit Weight (pcf)	Primary Settlement (in.)	Secondary Settlement (in.)
1	INCOMP.	16.5				125.00	0.00	0.00
2	COMP.	19.0	0.037	0.037	0.037	118.00	0.00	0.00
3	INCOMP.	31.0				130.00	0.00	0.00
Total Settlement =							0.00	0.00

N§.	Sublayer		Soil Stresses			Settlement (in.)
	Thick. (ft)	Elev. (ft)	Initial (psf)	Increment (psf)	Max.Past Press. (psf)	
1	INCOMP.					
2	1.90	119.05	2174.60	0.45	2174.60	0.00
3	1.90	117.15	2345.76	0.64	2345.76	0.00
4	1.90	115.25	2451.40	0.85	2451.40	0.00
5	1.90	113.35	2557.04	1.07	2557.04	0.00
6	1.90	111.45	2662.68	1.30	2662.68	0.00
7	1.90	109.55	2768.32	1.54	2768.32	0.00
8	1.90	107.65	2873.96	1.76	2873.96	0.00
9	1.90	105.75	2979.60	1.98	2979.60	0.00
10	1.90	103.85	3085.24	2.18	3085.24	0.00
11	1.90	101.95	3190.88	2.36	3190.88	0.00
12	INCOMP.					
Total Settlement =						0.00 (in.)

RECTANGULAR LOADS

Project Name: North St Culvert, Agawam Project Number : 177018.00
 Client : Woodard-Curran Project Manager: MJO
 Date : 4/6/2023 Computed by : MJO

Increment of stresses obtained using : Boussinesq

Settlement for X = 7.00 (ft) Y = 32.00 (ft)

Footing #	Corner Point P1		Corner Point P2		Load (psf)
	X1(ft)	Y1(ft)	X2(ft)	Y2(ft)	
1	29.00	101.00	45.00	118.50	181.00

Foundation Elev. = 131.50 (ft) Ground Surface Elev.= 135.00 (ft)
 Water table Elev. = 118.00 (ft) Unit weight of Wat. = 62.40 (pcf)

Nº.	Layer Type	Thick. (ft)	Comp. Ratio	Recomp. Ratio	Swell.	Unit Weight (pcf)	Primary Settlement (in.)	Secondary Settlement (in.)
1	INCOMP.	15.0				125.00	0.00	0.00
2	COMP.	19.0	0.037	0.037	0.037	118.00	0.00	0.00
3	INCOMP.	31.0				130.00	0.00	0.00
Total Settlement =							0.00	0.00

N§.	Sublayer		Soil Stresses			Settlement (in.)
	Thick. (ft)	Elev. (ft)	Initial (psf)	Increment (psf)	Max.Past Press. (psf)	
1	INCOMP.					
2	1.90	119.05	1987.10	0.01	1987.10	0.00
3	1.90	117.15	2158.26	0.02	2158.26	0.00
4	1.90	115.25	2263.90	0.02	2263.90	0.00
5	1.90	113.35	2369.54	0.03	2369.54	0.00
6	1.90	111.45	2475.18	0.04	2475.18	0.00
7	1.90	109.55	2580.82	0.06	2580.82	0.00
8	1.90	107.65	2686.46	0.07	2686.46	0.00
9	1.90	105.75	2792.10	0.08	2792.10	0.00
10	1.90	103.85	2897.74	0.10	2897.74	0.00
11	1.90	101.95	3003.38	0.12	3003.38	0.00
12	INCOMP.					
Total Settlement =						0.00 (in.)

RECTANGULAR LOADS

Project Name: North St Culvert, Agawam Project Number : 177018.00
 Client : Woodard-Curran Project Manager: MJO
 Date : 4/6/2023 Computed by : MJO

Increment of stresses obtained using : Boussinesq

Settlement for X = 7.00 (ft) Y = 39.50 (ft)

Footing #	Corner Point P1		Corner Point P2		Load (psf)
	X1(ft)	Y1(ft)	X2(ft)	Y2(ft)	
1	29.00	101.00	45.00	118.50	181.00

Foundation Elev. = 131.50 (ft) Ground Surface Elev.= 135.00 (ft)
 Water table Elev. = 118.00 (ft) Unit weight of Wat. = 62.40 (pcf)

Nº.	Layer Type	Thick. (ft)	Comp. Ratio	Recomp. Ratio	Swell.	Unit Weight (pcf)	Primary Settlement (in.)	Secondary Settlement (in.)
1	INCOMP.	15.0				125.00	0.00	0.00
2	COMP.	19.0	0.037	0.037	0.037	118.00	0.00	0.00
3	INCOMP.	31.0				130.00	0.00	0.00
Total Settlement =							0.00	0.00

N§.	Sublayer		Soil Stresses			Settlement (in.)
	Thick. (ft)	Elev. (ft)	Initial (psf)	Increment (psf)	Max.Past Press. (psf)	
1	INCOMP.					
2	1.90	119.05	1987.10	0.02	1987.10	0.00
3	1.90	117.15	2158.26	0.03	2158.26	0.00
4	1.90	115.25	2263.90	0.04	2263.90	0.00
5	1.90	113.35	2369.54	0.05	2369.54	0.00
6	1.90	111.45	2475.18	0.07	2475.18	0.00
7	1.90	109.55	2580.82	0.08	2580.82	0.00
8	1.90	107.65	2686.46	0.10	2686.46	0.00
9	1.90	105.75	2792.10	0.13	2792.10	0.00
10	1.90	103.85	2897.74	0.15	2897.74	0.00
11	1.90	101.95	3003.38	0.18	3003.38	0.00
12	INCOMP.					
Total Settlement =						0.00 (in.)

RECTANGULAR LOADS

Project Name: North St Culvert, Agawam Project Number : 177018.00
 Client : Woodard-Curran Project Manager: MJO
 Date : 4/6/2023 Computed by : MJO

Increment of stresses obtained using : Boussinesq

Settlement for X = 7.00 (ft) Y = 86.50 (ft)

Footing #	Corner Point P1		Corner Point P2		Load (psf)
	X1(ft)	Y1(ft)	X2(ft)	Y2(ft)	
1	29.00	101.00	45.00	118.50	181.00

Foundation Elev. = 131.50 (ft) Ground Surface Elev.= 135.00 (ft)
 Water table Elev. = 118.00 (ft) Unit weight of Wat. = 62.40 (pcf)

Nº.	Layer Type	Thick. (ft)	Comp. Ratio	Recomp. Ratio	Swell.	Unit Weight (pcf)	Primary Settlement (in.)	Secondary Settlement (in.)
1	INCOMP.	15.0				125.00	0.00	0.00
2	COMP.	19.0	0.037	0.037	0.037	118.00	0.00	0.00
3	INCOMP.	31.0				130.00	0.00	0.00
Total Settlement =							0.00	0.00

N§.	Sublayer		Soil Stresses			Settlement (in.)
	Thick. (ft)	Elev. (ft)	Initial (psf)	Increment (psf)	Max.Past Press. (psf)	
1	INCOMP.					
2	1.90	119.05	1987.10	0.54	1987.10	0.00
3	1.90	117.15	2158.26	0.75	2158.26	0.00
4	1.90	115.25	2263.90	0.99	2263.90	0.00
5	1.90	113.35	2369.54	1.24	2369.54	0.00
6	1.90	111.45	2475.18	1.49	2475.18	0.00
7	1.90	109.55	2580.82	1.74	2580.82	0.00
8	1.90	107.65	2686.46	1.98	2686.46	0.00
9	1.90	105.75	2792.10	2.20	2792.10	0.00
10	1.90	103.85	2897.74	2.39	2897.74	0.00
11	1.90	101.95	3003.38	2.57	3003.38	0.00
12	INCOMP.					
Total Settlement =						0.00 (in.)

RECTANGULAR LOADS

Project Name: North St Culvert, Agawam Project Number : 177018.00
 Client : Woodard-Curran Project Manager: MJO
 Date : 4/6/2023 Computed by : MJO

Increment of stresses obtained using : Boussinesq

Settlement for X = 7.00 (ft) Y = 109.80 (ft)

Footing #	Corner Point P1		Corner Point P2		Load (psf)
	X1(ft)	Y1(ft)	X2(ft)	Y2(ft)	
1	29.00	101.00	45.00	118.50	181.00

Foundation Elev. = 131.50 (ft) Ground Surface Elev.= 135.00 (ft)
 Water table Elev. = 118.00 (ft) Unit weight of Wat. = 62.40 (pcf)

Nº.	Layer Type	Thick. (ft)	Comp. Ratio	Recomp. Ratio	Swell.	Unit Weight (pcf)	Primary Settlement (in.)	Secondary Settlement (in.)
1	INCOMP.	15.0				125.00	0.00	0.00
2	COMP.	19.0	0.037	0.037	0.037	118.00	0.00	0.00
3	INCOMP.	31.0				130.00	0.00	0.00
Total Settlement =							0.00	0.00

N§.	Sublayer		Soil Stresses			Settlement (in.)
	Thick. (ft)	Elev. (ft)	Initial (psf)	Increment (psf)	Max.Past Press. (psf)	
1	INCOMP.					
2	1.90	119.05	1987.10	1.55	1987.10	0.00
3	1.90	117.15	2158.26	2.06	2158.26	0.00
4	1.90	115.25	2263.90	2.58	2263.90	0.00
5	1.90	113.35	2369.54	3.07	2369.54	0.00
6	1.90	111.45	2475.18	3.53	2475.18	0.00
7	1.90	109.55	2580.82	3.92	2580.82	0.00
8	1.90	107.65	2686.46	4.26	2686.46	0.00
9	1.90	105.75	2792.10	4.53	2792.10	0.00
10	1.90	103.85	2897.74	4.74	2897.74	0.00
11	1.90	101.95	3003.38	4.89	3003.38	0.00
12	INCOMP.					
Total Settlement =						0.00 (in.)

RECTANGULAR LOADS

Project Name: North St Culvert, Agawam Project Number : 177018.00
 Client : Woodard-Curran Project Manager: MJO
 Date : 4/6/2023 Computed by : MJO

Increment of stresses obtained using : Boussinesq

Settlement for X = 7.00 (ft) Y = 124.80 (ft)

Footing #	Corner Point P1		Corner Point P2		Load (psf)
	X1(ft)	Y1(ft)	X2(ft)	Y2(ft)	
1	29.00	101.00	45.00	118.50	181.00

Foundation Elev. = 131.50 (ft) Ground Surface Elev.= 135.00 (ft)
 Water table Elev. = 118.00 (ft) Unit weight of Wat. = 62.40 (pcf)

Nº.	Layer Type	Thick. (ft)	Comp. Ratio	Recomp. Ratio	Swell. Ratio	Unit Weight (pcf)	Primary Settlement (in.)	Secondary Settlement (in.)
1	INCOMP.	15.0				125.00	0.00	0.00
2	COMP.	19.0	0.037	0.037	0.037	118.00	0.00	0.00
3	INCOMP.	31.0				130.00	0.00	0.00
Total Settlement =							0.00	0.00

N§.	Sublayer		Soil Stresses			Settlement (in.)
	Thick. (ft)	Elev. (ft)	Initial (psf)	Increment (psf)	Max.Past Press. (psf)	
1	INCOMP.					
2	1.90	119.05	1987.10	0.95	1987.10	0.00
3	1.90	117.15	2158.26	1.30	2158.26	0.00
4	1.90	115.25	2263.90	1.66	2263.90	0.00
5	1.90	113.35	2369.54	2.03	2369.54	0.00
6	1.90	111.45	2475.18	2.39	2475.18	0.00
7	1.90	109.55	2580.82	2.72	2580.82	0.00
8	1.90	107.65	2686.46	3.01	2686.46	0.00
9	1.90	105.75	2792.10	3.27	2792.10	0.00
10	1.90	103.85	2897.74	3.49	2897.74	0.00
11	1.90	101.95	3003.38	3.67	3003.38	0.00
12	INCOMP.					
Total Settlement =						0.00 (in.)

RECTANGULAR LOADS

Project Name: North St Culvert, Agawam Project Number : 177018.00
 Client : Woodard-Curran Project Manager: MJO
 Date : 4/6/2023 Computed by : MJO

Increment of stresses obtained using : Boussinesq

Settlement for X = 7.00 (ft) Y = 138.00 (ft)

Footing #	Corner Point P1		Corner Point P2		Load (psf)
	X1(ft)	Y1(ft)	X2(ft)	Y2(ft)	
1	29.00	101.00	45.00	118.50	181.00

Foundation Elev. = 131.50 (ft) Ground Surface Elev.= 135.00 (ft)
 Water table Elev. = 118.00 (ft) Unit weight of Wat. = 62.40 (pcf)

Nº.	Layer Type	Thick. (ft)	Comp. Ratio	Recomp. Ratio	Swell.	Unit Weight (pcf)	Primary Settlement (in.)	Secondary Settlement (in.)
1	INCOMP.	15.0				125.00	0.00	0.00
2	COMP.	19.0	0.037	0.037	0.037	118.00	0.00	0.00
3	INCOMP.	31.0				130.00	0.00	0.00
Total Settlement =							0.00	0.00

N§.	Sublayer		Soil Stresses			Settlement (in.)
	Thick. (ft)	Elev. (ft)	Initial (psf)	Increment (psf)	Max.Past Press. (psf)	
1	INCOMP.					
2	1.90	119.05	1987.10	0.37	1987.10	0.00
3	1.90	117.15	2158.26	0.52	2158.26	0.00
4	1.90	115.25	2263.90	0.69	2263.90	0.00
5	1.90	113.35	2369.54	0.88	2369.54	0.00
6	1.90	111.45	2475.18	1.07	2475.18	0.00
7	1.90	109.55	2580.82	1.27	2580.82	0.00
8	1.90	107.65	2686.46	1.46	2686.46	0.00
9	1.90	105.75	2792.10	1.65	2792.10	0.00
10	1.90	103.85	2897.74	1.82	2897.74	0.00
11	1.90	101.95	3003.38	1.98	3003.38	0.00
12	INCOMP.					
Total Settlement =						0.00 (in.)

RECTANGULAR LOADS

Project Name: North St Culvert, Agawam Project Number : 177018.00
 Client : Woodard-Curran Project Manager: MJO
 Date : 4/6/2023 Computed by : MJO

Increment of stresses obtained using : Boussinesq

Settlement for X = 18.00 (ft) Y = 37.00 (ft)

Footing #	Corner Point P1		Corner Point P2		Load (psf)
	X1(ft)	Y1(ft)	X2(ft)	Y2(ft)	
1	29.00	101.00	45.00	118.50	181.00

Foundation Elev. = 131.50 (ft) Ground Surface Elev.= 135.00 (ft)
 Water table Elev. = 118.00 (ft) Unit weight of Wat. = 62.40 (pcf)

Nº.	Layer Type	Thick. (ft)	Comp. Ratio	Recomp. Ratio	Swell. Ratio	Unit Weight (pcf)	Primary Settlement (in.)	Secondary Settlement (in.)
1	INCOMP.	15.0				125.00	0.00	0.00
2	COMP.	19.0	0.037	0.037	0.037	118.00	0.00	0.00
3	INCOMP.	31.0				130.00	0.00	0.00
Total Settlement =							0.00	0.00

N§.	Sublayer		Soil Stresses			Settlement (in.)
	Thick. (ft)	Elev. (ft)	Initial (psf)	Increment (psf)	Max.Past Press. (psf)	
1	INCOMP.					
2	1.90	119.05	1987.10	0.02	1987.10	0.00
3	1.90	117.15	2158.26	0.03	2158.26	0.00
4	1.90	115.25	2263.90	0.04	2263.90	0.00
5	1.90	113.35	2369.54	0.05	2369.54	0.00
6	1.90	111.45	2475.18	0.07	2475.18	0.00
7	1.90	109.55	2580.82	0.09	2580.82	0.00
8	1.90	107.65	2686.46	0.11	2686.46	0.00
9	1.90	105.75	2792.10	0.14	2792.10	0.00
10	1.90	103.85	2897.74	0.16	2897.74	0.00
11	1.90	101.95	3003.38	0.19	3003.38	0.00
12	INCOMP.					
Total Settlement =						0.00 (in.)

RECTANGULAR LOADS

Project Name: North St Culvert, Agawam Project Number : 177018.00
 Client : Woodard-Curran Project Manager: MJO
 Date : 4/6/2023 Computed by : MJO

Increment of stresses obtained using : Boussinesq

Settlement for X = 18.00 (ft) Y = 47.50 (ft)

Footing #	Corner Point P1		Corner Point P2		Load (psf)
	X1(ft)	Y1(ft)	X2(ft)	Y2(ft)	
1	29.00	101.00	45.00	118.50	181.00

Foundation Elev. = 131.50 (ft) Ground Surface Elev.= 135.00 (ft)
 Water table Elev. = 118.00 (ft) Unit weight of Wat. = 62.40 (pcf)

Nº.	Layer Type	Thick. (ft)	Comp. Ratio	Recomp. Ratio	Swell.	Unit Weight (pcf)	Primary Settlement (in.)	Secondary Settlement (in.)
1	INCOMP.	15.0				125.00	0.00	0.00
2	COMP.	19.0	0.037	0.037	0.037	118.00	0.00	0.00
3	INCOMP.	31.0				130.00	0.00	0.00
Total Settlement =							0.00	0.00

N§.	Sublayer		Soil Stresses			Settlement (in.)
	Thick. (ft)	Elev. (ft)	Initial (psf)	Increment (psf)	Max.Past Press. (psf)	
1	INCOMP.					
2	1.90	119.05	1987.10	0.04	1987.10	0.00
3	1.90	117.15	2158.26	0.06	2158.26	0.00
4	1.90	115.25	2263.90	0.08	2263.90	0.00
5	1.90	113.35	2369.54	0.11	2369.54	0.00
6	1.90	111.45	2475.18	0.14	2475.18	0.00
7	1.90	109.55	2580.82	0.18	2580.82	0.00
8	1.90	107.65	2686.46	0.22	2686.46	0.00
9	1.90	105.75	2792.10	0.26	2792.10	0.00
10	1.90	103.85	2897.74	0.30	2897.74	0.00
11	1.90	101.95	3003.38	0.35	3003.38	0.00
12	INCOMP.					
Total Settlement =						0.00 (in.)

RECTANGULAR LOADS

Project Name: North St Culvert, Agawam Project Number : 177018.00
 Client : Woodard-Curran Project Manager: MJO
 Date : 4/6/2023 Computed by : MJO

Increment of stresses obtained using : Boussinesq

Settlement for X = 18.00 (ft) Y = 86.50 (ft)

Footing #	Corner Point P1		Corner Point P2		Load (psf)
	X1(ft)	Y1(ft)	X2(ft)	Y2(ft)	
1	29.00	101.00	45.00	118.50	181.00

Foundation Elev. = 131.50 (ft) Ground Surface Elev.= 135.00 (ft)
 Water table Elev. = 118.00 (ft) Unit weight of Wat. = 62.40 (pcf)

Nº.	Layer Type	Thick. (ft)	Comp. Ratio	Recomp. Ratio	Swell.	Unit Weight (pcf)	Primary Settlement (in.)	Secondary Settlement (in.)
1	INCOMP.	15.0				125.00	0.00	0.00
2	COMP.	19.0	0.037	0.037	0.037	118.00	0.01	0.00
3	INCOMP.	31.0				130.00	0.00	0.00
Total Settlement =							0.01	0.00

N§.	Sublayer		Soil Stresses			Settlement (in.)
	Thick. (ft)	Elev. (ft)	Initial (psf)	Increment (psf)	Max.Past Press. (psf)	
1	INCOMP.					
2	1.90	119.05	1987.10	1.64	1987.10	0.00
3	1.90	117.15	2158.26	2.17	2158.26	0.00
4	1.90	115.25	2263.90	2.69	2263.90	0.00
5	1.90	113.35	2369.54	3.19	2369.54	0.00
6	1.90	111.45	2475.18	3.63	2475.18	0.00
7	1.90	109.55	2580.82	4.02	2580.82	0.00
8	1.90	107.65	2686.46	4.35	2686.46	0.00
9	1.90	105.75	2792.10	4.61	2792.10	0.00
10	1.90	103.85	2897.74	4.81	2897.74	0.00
11	1.90	101.95	3003.38	4.96	3003.38	0.00
12	INCOMP.					
Total Settlement =						0.01 (in.)

RECTANGULAR LOADS

Project Name: North St Culvert, Agawam Project Number : 177018.00
 Client : Woodard-Curran Project Manager: MJO
 Date : 4/6/2023 Computed by : MJO

Increment of stresses obtained using : Boussinesq

Settlement for X = 18.00 (ft) Y = 125.50 (ft)

Footing #	Corner Point P1		Corner Point P2		Load (psf)
	X1(ft)	Y1(ft)	X2(ft)	Y2(ft)	
1	29.00	101.00	45.00	118.50	181.00

Foundation Elev. = 131.50 (ft) Ground Surface Elev.= 135.00 (ft)
 Water table Elev. = 118.00 (ft) Unit weight of Wat. = 62.40 (pcf)

Nº.	Layer Type	Thick. (ft)	Comp. Ratio	Recomp. Ratio	Swell.	Unit Weight (pcf)	Primary Settlement (in.)	Secondary Settlement (in.)
1	INCOMP.	15.0				125.00	0.00	0.00
2	COMP.	19.0	0.037	0.037	0.037	118.00	0.01	0.00
3	INCOMP.	31.0				130.00	0.00	0.00
Total Settlement =							0.01	0.00

N§.	Sublayer		Soil Stresses			Settlement (in.)
	Thick. (ft)	Elev. (ft)	Initial (psf)	Increment (psf)	Max.Past Press. (psf)	
1	INCOMP.					
2	1.90	119.05	1987.10	3.86	1987.10	0.00
3	1.90	117.15	2158.26	4.78	2158.26	0.00
4	1.90	115.25	2263.90	5.59	2263.90	0.00
5	1.90	113.35	2369.54	6.26	2369.54	0.00
6	1.90	111.45	2475.18	6.79	2475.18	0.00
7	1.90	109.55	2580.82	7.17	2580.82	0.00
8	1.90	107.65	2686.46	7.43	2686.46	0.00
9	1.90	105.75	2792.10	7.57	2792.10	0.00
10	1.90	103.85	2897.74	7.63	2897.74	0.00
11	1.90	101.95	3003.38	7.61	3003.38	0.00
12	INCOMP.					
Total Settlement =						0.01 (in.)

RECTANGULAR LOADS

Project Name: North St Culvert, Agawam Project Number : 177018.00
 Client : Woodard-Curran Project Manager: MJO
 Date : 4/6/2023 Computed by : MJO

Increment of stresses obtained using : Boussinesq

Settlement for X = 18.00 (ft) Y = 135.80 (ft)

Footing #	Corner Point P1		Corner Point P2		Load (psf)
	X1(ft)	Y1(ft)	X2(ft)	Y2(ft)	
1	29.00	101.00	45.00	118.50	181.00

Foundation Elev. = 131.50 (ft) Ground Surface Elev.= 135.00 (ft)
 Water table Elev. = 118.00 (ft) Unit weight of Wat. = 62.40 (pcf)

Nº.	Layer Type	Thick. (ft)	Comp. Ratio	Recomp. Ratio	Swell.	Unit Weight (pcf)	Primary Settlement (in.)	Secondary Settlement (in.)
1	INCOMP.	15.0				125.00	0.00	0.00
2	COMP.	19.0	0.037	0.037	0.037	118.00	0.00	0.00
3	INCOMP.	31.0				130.00	0.00	0.00
Total Settlement =							0.00	0.00

N§.	Sublayer		Soil Stresses			Settlement (in.)
	Thick. (ft)	Elev. (ft)	Initial (psf)	Increment (psf)	Max.Past Press. (psf)	
1	INCOMP.					
2	1.90	119.05	1987.10	1.18	1987.10	0.00
3	1.90	117.15	2158.26	1.59	2158.26	0.00
4	1.90	115.25	2263.90	2.01	2263.90	0.00
5	1.90	113.35	2369.54	2.43	2369.54	0.00
6	1.90	111.45	2475.18	2.82	2475.18	0.00
7	1.90	109.55	2580.82	3.17	2580.82	0.00
8	1.90	107.65	2686.46	3.48	2686.46	0.00
9	1.90	105.75	2792.10	3.75	2792.10	0.00
10	1.90	103.85	2897.74	3.96	2897.74	0.00
11	1.90	101.95	3003.38	4.13	3003.38	0.00
12	INCOMP.					
Total Settlement =						0.00 (in.)

RECTANGULAR LOADS

Project Name: North St Culvert, Agawam Project Number : 177018.00
 Client : Woodard-Curran Project Manager: MJO
 Date : 4/6/2023 Computed by : MJO

Increment of stresses obtained using : Boussinesq

Settlement for X = 18.00 (ft) Y = 145.00 (ft)

Footing #	Corner Point P1		Corner Point P2		Load (psf)
	X1(ft)	Y1(ft)	X2(ft)	Y2(ft)	
1	29.00	101.00	45.00	118.50	181.00

Foundation Elev. = 131.50 (ft) Ground Surface Elev.= 135.00 (ft)
 Water table Elev. = 118.00 (ft) Unit weight of Wat. = 62.40 (pcf)

Nº.	Layer Type	Thick. (ft)	Comp. Ratio	Recomp. Ratio	Swell.	Unit Weight (pcf)	Primary Settlement (in.)	Secondary Settlement (in.)
1	INCOMP.	15.0				125.00	0.00	0.00
2	COMP.	19.0	0.037	0.037	0.037	118.00	0.00	0.00
3	INCOMP.	31.0				130.00	0.00	0.00
Total Settlement =							0.00	0.00

N§.	Sublayer		Soil Stresses			Settlement (in.)
	Thick. (ft)	Elev. (ft)	Initial (psf)	Increment (psf)	Max.Past Press. (psf)	
1	INCOMP.					
2	1.90	119.05	1987.10	0.42	1987.10	0.00
3	1.90	117.15	2158.26	0.60	2158.26	0.00
4	1.90	115.25	2263.90	0.79	2263.90	0.00
5	1.90	113.35	2369.54	1.00	2369.54	0.00
6	1.90	111.45	2475.18	1.21	2475.18	0.00
7	1.90	109.55	2580.82	1.43	2580.82	0.00
8	1.90	107.65	2686.46	1.64	2686.46	0.00
9	1.90	105.75	2792.10	1.83	2792.10	0.00
10	1.90	103.85	2897.74	2.02	2897.74	0.00
11	1.90	101.95	3003.38	2.18	3003.38	0.00
12	INCOMP.					
Total Settlement =						0.00 (in.)

RECTANGULAR LOADS

Project Name: North St Culvert, Agawam Project Number : 177018.00
 Client : Woodard-Curran Project Manager: MJO
 Date : 4/6/2023 Computed by : MJO

Increment of stresses obtained using : Boussinesq

Settlement for X = 7.00 (ft) Y = 86.50 (ft)

Footing #	Corner Point P1		Corner Point P2		Load (psf)
	X1(ft)	Y1(ft)	X2(ft)	Y2(ft)	
1	7.00	67.00	29.00	106.00	490.00

Foundation Elev. = 115.30 (ft) Ground Surface Elev.= 135.00 (ft)
 Water table Elev. = 118.00 (ft) Unit weight of Wat. = 62.40 (pcf)

Nº.	Layer Type	Thick. (ft)	Comp. Ratio	Recomp. Ratio	Swell. Ratio	Unit Weight (pcf)	Primary Settlement (in.)	Secondary Settlement (in.)
1	INCOMP.	15.0				125.00	0.00	0.00
2	COMP.	34.5	0.037	0.037	0.037	118.00	0.37	0.00
3	INCOMP.	15.5				130.00	0.00	0.00
Total Settlement =							0.37	0.00

N§.	Sublayer		Soil Stresses			Settlement (in.)
	Thick. (ft)	Elev. (ft)	Initial (psf)	Increment (psf)	Max.Past Press. (psf)	
1	INCOMP.					
2	Sublayer over foundation Elev.					
3	2.20	114.20	2322.28	244.97	2322.28	0.04
4	3.45	111.38	2479.35	243.78	2479.35	0.06
5	3.45	107.92	2671.17	237.78	2671.17	0.06
6	3.45	104.47	2862.99	225.61	2862.99	0.05
7	3.45	101.03	3054.81	208.51	3054.81	0.04
8	3.45	97.57	3246.63	188.82	3246.63	0.04
9	3.45	94.13	3438.45	168.66	3438.45	0.03
10	3.45	90.67	3630.27	149.46	3630.27	0.03
11	3.45	87.22	3822.09	131.96	3822.09	0.02
12	INCOMP.					
Total Settlement =						0.37 (in.)

RECTANGULAR LOADS

Project Name: North St Culvert, Agawam Project Number : 177018.00
 Client : Woodard-Curran Project Manager: MJO
 Date : 4/6/2023 Computed by : MJO

Increment of stresses obtained using : Boussinesq

Settlement for X = 7.00 (ft) Y = 109.80 (ft)

Footing #	Corner Point P1		Corner Point P2		Load (psf)
	X1(ft)	Y1(ft)	X2(ft)	Y2(ft)	
1	7.00	67.00	29.00	106.00	490.00

Foundation Elev. = 115.30 (ft) Ground Surface Elev.= 135.00 (ft)
 Water table Elev. = 118.00 (ft) Unit weight of Wat. = 62.40 (pcf)

Nº.	Layer Type	Thick. (ft)	Comp. Ratio	Recomp. Ratio	Swell. Ratio	Unit Weight (pcf)	Primary Settlement (in.)	Secondary Settlement (in.)
1	INCOMP.	15.0				125.00	0.00	0.00
2	COMP.	34.5	0.037	0.037	0.037	118.00	0.11	0.00
3	INCOMP.	15.5				130.00	0.00	0.00
Total Settlement =							0.11	0.00

N§.	Sublayer		Soil Stresses			Settlement (in.)
	Thick. (ft)	Elev. (ft)	Initial (psf)	Increment (psf)	Max.Past Press. (psf)	
1	INCOMP.					
2	Sublayer over foundation Elev.					
3	2.20	114.20	2322.28	1.14	2322.28	0.00
4	3.45	111.38	2479.35	23.29	2479.35	0.01
5	3.45	107.92	2671.17	52.11	2671.17	0.01
6	3.45	104.47	2862.99	67.47	2862.99	0.02
7	3.45	101.03	3054.81	74.23	3054.81	0.02
8	3.45	97.57	3246.63	76.05	3246.63	0.02
9	3.45	94.13	3438.45	74.98	3438.45	0.01
10	3.45	90.67	3630.27	72.26	3630.27	0.01
11	3.45	87.22	3822.09	68.64	3822.09	0.01
12	INCOMP.					
Total Settlement =						0.11 (in.)

RECTANGULAR LOADS

Project Name: North St Culvert, Agawam Project Number : 177018.00
 Client : Woodard-Curran Project Manager: MJO
 Date : 4/6/2023 Computed by : MJO

Increment of stresses obtained using : Boussinesq

Settlement for X = 7.00 (ft) Y = 124.80 (ft)

Footing #	Corner Point P1		Corner Point P2		Load (psf)
	X1(ft)	Y1(ft)	X2(ft)	Y2(ft)	
1	7.00	67.00	29.00	106.00	490.00

Foundation Elev. = 115.30 (ft) Ground Surface Elev.= 135.00 (ft)
 Water table Elev. = 118.00 (ft) Unit weight of Wat. = 62.40 (pcf)

Nº.	Layer Type	Thick. (ft)	Comp. Ratio	Recomp. Ratio	Swell. Ratio	Unit Weight (pcf)	Primary Settlement (in.)	Secondary Settlement (in.)
1	INCOMP.	15.0				125.00	0.00	0.00
2	COMP.	34.5	0.037	0.037	0.037	118.00	0.02	0.00
3	INCOMP.	15.5				130.00	0.00	0.00
Total Settlement =							0.02	0.00

N§.	Sublayer		Soil Stresses			Settlement (in.)
	Thick. (ft)	Elev. (ft)	Initial (psf)	Increment (psf)	Max.Past Press. (psf)	
1	INCOMP.					
2	Sublayer over foundation Elev.					
3	2.20	114.20	2322.28	0.01	2322.28	0.00
4	3.45	111.38	2479.35	0.36	2479.35	0.00
5	3.45	107.92	2671.17	2.07	2671.17	0.00
6	3.45	104.47	2862.99	5.32	2862.99	0.00
7	3.45	101.03	3054.81	9.53	3054.81	0.00
8	3.45	97.57	3246.63	13.88	3246.63	0.00
9	3.45	94.13	3438.45	17.79	3438.45	0.00
10	3.45	90.67	3630.27	20.98	3630.27	0.00
11	3.45	87.22	3822.09	23.37	3822.09	0.00
12	INCOMP.					
Total Settlement =						0.02 (in.)

RECTANGULAR LOADS

Project Name: North St Culvert, Agawam Project Number : 177018.00
 Client : Woodard-Curran Project Manager: MJO
 Date : 4/6/2023 Computed by : MJO

Increment of stresses obtained using : Boussinesq

Settlement for X = 18.00 (ft) Y = 37.00 (ft)

Footing #	Corner Point P1		Corner Point P2		Load (psf)
	X1(ft)	Y1(ft)	X2(ft)	Y2(ft)	
1	7.00	67.00	29.00	106.00	490.00

Foundation Elev. = 115.30 (ft) Ground Surface Elev.= 135.00 (ft)
 Water table Elev. = 118.00 (ft) Unit weight of Wat. = 62.40 (pcf)

Nº.	Layer Type	Thick. (ft)	Comp. Ratio	Recomp. Ratio	Swell. Ratio	Unit Weight (pcf)	Primary Settlement (in.)	Secondary Settlement (in.)
1	INCOMP.	15.0				125.00	0.00	0.00
2	COMP.	34.5	0.037	0.037	0.037	118.00	0.01	0.00
3	INCOMP.	15.5				130.00	0.00	0.00
Total Settlement =							0.01	0.00

N§.	Sublayer		Soil Stresses			Settlement (in.)
	Thick. (ft)	Elev. (ft)	Initial (psf)	Increment (psf)	Max.Past Press. (psf)	
1	INCOMP.					
2	Sublayer over foundation Elev.					
3	2.20	114.20	2322.28	0.00	2322.28	0.00
4	3.45	111.38	2479.35	0.08	2479.35	0.00
5	3.45	107.92	2671.17	0.52	2671.17	0.00
6	3.45	104.47	2862.99	1.47	2862.99	0.00
7	3.45	101.03	3054.81	2.95	3054.81	0.00
8	3.45	97.57	3246.63	4.80	3246.63	0.00
9	3.45	94.13	3438.45	6.82	3438.45	0.00
10	3.45	90.67	3630.27	8.85	3630.27	0.00
11	3.45	87.22	3822.09	10.72	3822.09	0.00
12	INCOMP.					
Total Settlement =						0.01 (in.)

RECTANGULAR LOADS

Project Name: North St Culvert, Agawam Project Number : 177018.00
 Client : Woodard-Curran Project Manager: MJO
 Date : 4/6/2023 Computed by : MJO

Increment of stresses obtained using : Boussinesq

Settlement for X = 18.00 (ft) Y = 47.50 (ft)

Footing #	Corner Point P1		Corner Point P2		Load (psf)
	X1(ft)	Y1(ft)	X2(ft)	Y2(ft)	
1	7.00	67.00	29.00	106.00	490.00

Foundation Elev. = 115.30 (ft) Ground Surface Elev.= 135.00 (ft)
 Water table Elev. = 118.00 (ft) Unit weight of Wat. = 62.40 (pcf)

Nº.	Layer Type	Thick. (ft)	Comp. Ratio	Recomp. Ratio	Swell. Ratio	Unit Weight (pcf)	Primary Settlement (in.)	Secondary Settlement (in.)
1	INCOMP.	15.0				125.00	0.00	0.00
2	COMP.	34.5	0.037	0.037	0.037	118.00	0.02	0.00
3	INCOMP.	15.5				130.00	0.00	0.00
Total Settlement =							0.02	0.00

N§.	Sublayer		Soil Stresses			Settlement (in.)
	Thick. (ft)	Elev. (ft)	Initial (psf)	Increment (psf)	Max.Past Press. (psf)	
1	INCOMP.					
2	Sublayer over foundation Elev.					
3	2.20	114.20	2322.28	0.01	2322.28	0.00
4	3.45	111.38	2479.35	0.43	2479.35	0.00
5	3.45	107.92	2671.17	2.45	2671.17	0.00
6	3.45	104.47	2862.99	6.24	2862.99	0.00
7	3.45	101.03	3054.81	11.03	3054.81	0.00
8	3.45	97.57	3246.63	15.85	3246.63	0.00
9	3.45	94.13	3438.45	20.04	3438.45	0.00
10	3.45	90.67	3630.27	23.33	3630.27	0.00
11	3.45	87.22	3822.09	25.68	3822.09	0.00
12	INCOMP.					
Total Settlement =						0.02 (in.)

RECTANGULAR LOADS

Project Name: North St Culvert, Agawam Project Number : 177018.00
 Client : Woodard-Curran Project Manager: MJO
 Date : 4/6/2023 Computed by : MJO

Increment of stresses obtained using : Boussinesq

Settlement for X = 18.00 (ft) Y = 86.50 (ft)

Footing #	Corner Point P1		Corner Point P2		Load (psf)
	X1(ft)	Y1(ft)	X2(ft)	Y2(ft)	
1	7.00	67.00	29.00	106.00	490.00

Foundation Elev. = 115.30 (ft) Ground Surface Elev.= 135.00 (ft)
 Water table Elev. = 118.00 (ft) Unit weight of Wat. = 62.40 (pcf)

Nº.	Layer Type	Thick. (ft)	Comp. Ratio	Recomp. Ratio	Swell. Ratio	Unit Weight (pcf)	Primary Settlement (in.)	Secondary Settlement (in.)
1	INCOMP.	15.0				125.00	0.00	0.00
2	COMP.	34.5	0.037	0.037	0.037	118.00	0.62	0.00
3	INCOMP.	15.5				130.00	0.00	0.00
Total Settlement =							0.62	0.00

N§.	Sublayer		Soil Stresses			Settlement (in.)
	Thick. (ft)	Elev. (ft)	Initial (psf)	Increment (psf)	Max.Past Press. (psf)	
1	INCOMP.					
2	Sublayer over foundation Elev.					
3	2.20	114.20	2322.28	489.77	2322.28	0.08
4	3.45	111.38	2479.35	480.95	2479.35	0.12
5	3.45	107.92	2671.17	445.07	2671.17	0.10
6	3.45	104.47	2862.99	390.71	2862.99	0.09
7	3.45	101.03	3054.81	333.00	3054.81	0.07
8	3.45	97.57	3246.63	280.29	3246.63	0.06
9	3.45	94.13	3438.45	235.31	3438.45	0.04
10	3.45	90.67	3630.27	198.10	3630.27	0.04
11	3.45	87.22	3822.09	167.71	3822.09	0.03
12	INCOMP.					
Total Settlement =						0.62 (in.)

RECTANGULAR LOADS

Project Name: North St Culvert, Agawam Project Number : 177018.00
 Client : Woodard-Curran Project Manager: MJO
 Date : 4/6/2023 Computed by : MJO

Increment of stresses obtained using : Boussinesq

Settlement for X = 18.00 (ft) Y = 125.50 (ft)

Footing #	Corner Point P1		Corner Point P2		Load (psf)
	X1(ft)	Y1(ft)	X2(ft)	Y2(ft)	
1	7.00	67.00	29.00	106.00	490.00

Foundation Elev. = 115.30 (ft) Ground Surface Elev.= 135.00 (ft)
 Water table Elev. = 118.00 (ft) Unit weight of Wat. = 62.40 (pcf)

Nº.	Layer Type	Thick. (ft)	Comp. Ratio	Recomp. Ratio	Swell.	Unit Weight (pcf)	Primary Settlement (in.)	Secondary Settlement (in.)
1	INCOMP.	15.0				125.00	0.00	0.00
2	COMP.	34.5	0.037	0.037	0.037	118.00	0.02	0.00
3	INCOMP.	15.5				130.00	0.00	0.00
Total Settlement =							0.02	0.00

N§.	Sublayer		Soil Stresses			Settlement (in.)
	Thick. (ft)	Elev. (ft)	Initial (psf)	Increment (psf)	Max.Past Press. (psf)	
1	INCOMP.					
2	Sublayer over foundation Elev.					
3	2.20	114.20	2322.28	0.01	2322.28	0.00
4	3.45	111.38	2479.35	0.43	2479.35	0.00
5	3.45	107.92	2671.17	2.45	2671.17	0.00
6	3.45	104.47	2862.99	6.24	2862.99	0.00
7	3.45	101.03	3054.81	11.03	3054.81	0.00
8	3.45	97.57	3246.63	15.85	3246.63	0.00
9	3.45	94.13	3438.45	20.04	3438.45	0.00
10	3.45	90.67	3630.27	23.33	3630.27	0.00
11	3.45	87.22	3822.09	25.68	3822.09	0.00
12	INCOMP.					
Total Settlement =						0.02 (in.)

RECTANGULAR LOADS

Project Name: North St Culvert, Agawam Project Number : 177018.00
 Client : Woodard-Curran Project Manager: MJO
 Date : 4/6/2023 Computed by : MJO

Increment of stresses obtained using : Boussinesq

Settlement for X = 7.00 (ft) Y = 32.00 (ft)

Footing #	Corner Point P1		Corner Point P2		Load (psf)
	X1(ft)	Y1(ft)	X2(ft)	Y2(ft)	
1	7.00	28.00	29.00	67.00	510.00

Foundation Elev. = 117.00 (ft) Ground Surface Elev.= 132.50 (ft)
 Water table Elev. = 118.00 (ft) Unit weight of Wat. = 62.40 (pcf)

Nº.	Layer Type	Thick. (ft)	Comp. Ratio	Recomp. Ratio	Swell. Ratio	Unit Weight (pcf)	Primary Settlement (in.)	Secondary Settlement (in.)
1	INCOMP.	11.5				125.00	0.00	0.00
2	COMP.	43.0	0.037	0.037	0.037	118.00	0.41	0.00
3	INCOMP.	8.0				130.00	0.00	0.00
Total Settlement =							0.41	0.00

N§.	Sublayer		Soil Stresses			Settlement (in.)
	Thick. (ft)	Elev. (ft)	Initial (psf)	Increment (psf)	Max.Past Press. (psf)	
1	INCOMP.					
2	0.30	116.85	1855.44	255.00	1855.44	0.01
3	4.30	114.55	1983.32	246.45	1983.32	0.10
4	4.30	110.25	2222.40	204.63	2222.40	0.07
5	4.30	105.95	2461.48	174.63	2461.48	0.06
6	4.30	101.65	2700.56	152.68	2700.56	0.05
7	4.30	97.35	2939.64	134.22	2939.64	0.04
8	4.30	93.05	3178.72	117.98	3178.72	0.03
9	4.30	88.75	3417.80	103.65	3417.80	0.02
10	4.30	84.45	3656.88	91.11	3656.88	0.02
11	4.30	80.15	3895.96	80.22	3895.96	0.02
12	INCOMP.					
Total Settlement =						0.41 (in.)

RECTANGULAR LOADS

Project Name: North St Culvert, Agawam Project Number : 177018.00
 Client : Woodard-Curran Project Manager: MJO
 Date : 4/6/2023 Computed by : MJO

Increment of stresses obtained using : Boussinesq

Settlement for X = 7.00 (ft) Y = 39.50 (ft)

Footing #	Corner Point P1		Corner Point P2		Load (psf)
	X1(ft)	Y1(ft)	X2(ft)	Y2(ft)	
1	7.00	28.00	29.00	67.00	510.00

Foundation Elev. = 117.00 (ft) Ground Surface Elev.= 132.50 (ft)
 Water table Elev. = 118.00 (ft) Unit weight of Wat. = 62.40 (pcf)

Nº.	Layer Type	Thick. (ft)	Comp. Ratio	Recomp. Ratio	Swell. Ratio	Unit Weight (pcf)	Primary Settlement (in.)	Secondary Settlement (in.)
1	INCOMP.	11.5				125.00	0.00	0.00
2	COMP.	43.0	0.037	0.037	0.037	118.00	0.48	0.00
3	INCOMP.	8.0				130.00	0.00	0.00
Total Settlement =							0.48	0.00

N§.	Sublayer		Soil Stresses			Settlement (in.)
	Thick. (ft)	Elev. (ft)	Initial (psf)	Increment (psf)	Max.Past Press. (psf)	
1	INCOMP.					
2	0.30	116.85	1855.44	255.00	1855.44	0.01
3	4.30	114.55	1983.32	254.37	1983.32	0.10
4	4.30	110.25	2222.40	244.75	2222.40	0.09
5	4.30	105.95	2461.48	223.79	2461.48	0.07
6	4.30	101.65	2700.56	197.93	2700.56	0.06
7	4.30	97.35	2939.64	171.96	2939.64	0.05
8	4.30	93.05	3178.72	148.13	3178.72	0.04
9	4.30	88.75	3417.80	127.28	3417.80	0.03
10	4.30	84.45	3656.88	109.48	3656.88	0.02
11	4.30	80.15	3895.96	94.48	3895.96	0.02
12	INCOMP.					
Total Settlement =						0.48 (in.)

RECTANGULAR LOADS

Project Name: North St Culvert, Agawam Project Number : 177018.00
 Client : Woodard-Curran Project Manager: MJO
 Date : 4/6/2023 Computed by : MJO

Increment of stresses obtained using : Boussinesq

Settlement for X = 18.00 (ft) Y = 37.00 (ft)

Footing #	Corner Point P1		Corner Point P2		Load (psf)
	X1(ft)	Y1(ft)	X2(ft)	Y2(ft)	
1	7.00	28.00	29.00	67.00	510.00

Foundation Elev. = 117.00 (ft) Ground Surface Elev.= 132.50 (ft)
 Water table Elev. = 118.00 (ft) Unit weight of Wat. = 62.40 (pcf)

Nº.	Layer Type	Thick. (ft)	Comp. Ratio	Recomp. Ratio	Swell.	Unit Weight (pcf)	Primary Settlement (in.)	Secondary Settlement (in.)
1	INCOMP.	11.5				125.00	0.00	0.00
2	COMP.	43.0	0.037	0.037	0.037	118.00	0.76	0.00
3	INCOMP.	8.0				130.00	0.00	0.00
Total Settlement =							0.76	0.00

N§.	Sublayer		Soil Stresses			Settlement (in.)
	Thick. (ft)	Elev. (ft)	Initial (psf)	Increment (psf)	Max.Past Press. (psf)	
1	INCOMP.					
2	0.30	116.85	1855.44	510.00	1855.44	0.01
3	4.30	114.55	1983.32	506.07	1983.32	0.19
4	4.30	110.25	2222.40	455.25	2222.40	0.15
5	4.30	105.95	2461.48	370.72	2461.48	0.12
6	4.30	101.65	2700.56	292.84	2700.56	0.09
7	4.30	97.35	2939.64	232.30	2939.64	0.06
8	4.30	93.05	3178.72	186.93	3178.72	0.05
9	4.30	88.75	3417.80	152.77	3417.80	0.04
10	4.30	84.45	3656.88	126.66	3656.88	0.03
11	4.30	80.15	3895.96	106.36	3895.96	0.02
12	INCOMP.					
Total Settlement =						0.76 (in.)

RECTANGULAR LOADS

Project Name: North St Culvert, Agawam Project Number : 177018.00
 Client : Woodard-Curran Project Manager: MJO
 Date : 4/6/2023 Computed by : MJO

Increment of stresses obtained using : Boussinesq

Settlement for X = 18.00 (ft) Y = 47.50 (ft)

Footing #	Corner Point P1		Corner Point P2		Load (psf)
	X1(ft)	Y1(ft)	X2(ft)	Y2(ft)	
1	7.00	28.00	29.00	67.00	510.00

Foundation Elev. = 117.00 (ft) Ground Surface Elev.= 132.50 (ft)
 Water table Elev. = 118.00 (ft) Unit weight of Wat. = 62.40 (pcf)

Nº.	Layer Type	Thick. (ft)	Comp. Ratio	Recomp. Ratio	Swell.	Unit Weight (pcf)	Primary Settlement (in.)	Secondary Settlement (in.)
1	INCOMP.	11.5				125.00	0.00	0.00
2	COMP.	43.0	0.037	0.037	0.037	118.00	0.81	0.00
3	INCOMP.	8.0				130.00	0.00	0.00
Total Settlement =							0.81	0.00

N§.	Sublayer		Soil Stresses			Settlement (in.)
	Thick. (ft)	Elev. (ft)	Initial (psf)	Increment (psf)	Max.Past Press. (psf)	
1	INCOMP.					
2	0.30	116.85	1855.44	510.00	1855.44	0.01
3	4.30	114.55	1983.32	507.52	1983.32	0.19
4	4.30	110.25	2222.40	471.93	2222.40	0.16
5	4.30	105.95	2461.48	402.71	2461.48	0.13
6	4.30	101.65	2700.56	328.72	2700.56	0.10
7	4.30	97.35	2939.64	264.58	2939.64	0.07
8	4.30	93.05	3178.72	213.16	3178.72	0.05
9	4.30	88.75	3417.80	173.11	3417.80	0.04
10	4.30	84.45	3656.88	142.12	3656.88	0.03
11	4.30	80.15	3895.96	118.05	3895.96	0.02
12	INCOMP.					
Total Settlement =						0.81 (in.)

RECTANGULAR LOADS

Project Name: North St Culvert, Agawam Project Number : 177018.00
 Client : Woodard-Curran Project Manager: MJO
 Date : 4/6/2023 Computed by : MJO

Increment of stresses obtained using : Boussinesq

Settlement for X = 7.00 (ft) Y = 32.00 (ft)

Footing #	Corner Point P1		Corner Point P2		Load (psf)
	X1(ft)	Y1(ft)	X2(ft)	Y2(ft)	
1	7.00	32.00	33.00	37.00	90.00

Foundation Elev. = 117.00 (ft) Ground Surface Elev.= 132.50 (ft)
 Water table Elev. = 118.00 (ft) Unit weight of Wat. = 62.40 (pcf)

Nº.	Layer Type	Thick. (ft)	Comp. Ratio	Recomp. Ratio	Swell. Ratio	Unit Weight (pcf)	Primary Settlement (in.)	Secondary Settlement (in.)
1	INCOMP.	11.5				125.00	0.00	0.00
2	COMP.	43.0	0.250	0.037	0.037	118.00	0.19	0.00
3	INCOMP.	8.0				130.00	0.00	0.00
Total Settlement =							0.19	0.00

N§.	Sublayer		Soil Stresses			Settlement (in.)
	Thick. (ft)	Elev. (ft)	Initial (psf)	Increment (psf)	Max.Past Press. (psf)	
1	INCOMP.					
2	0.30	116.85	1855.44	22.50	1855.44	0.00
3	4.30	114.55	1983.32	21.63	1983.32	0.06
4	4.30	110.25	2222.40	15.95	2222.40	0.04
5	4.30	105.95	2461.48	11.35	2461.48	0.03
6	4.30	101.65	2700.56	8.48	2700.56	0.02
7	4.30	97.35	2939.64	6.58	2939.64	0.01
8	4.30	93.05	3178.72	5.25	3178.72	0.01
9	4.30	88.75	3417.80	4.27	3417.80	0.01
10	4.30	84.45	3656.88	3.52	3656.88	0.01
11	4.30	80.15	3895.96	2.95	3895.96	0.00
12	INCOMP.					
Total Settlement =						0.19 (in.)

RECTANGULAR LOADS

Project Name: North St Culvert, Agawam Project Number : 177018.00
 Client : Woodard-Curran Project Manager: MJO
 Date : 4/6/2023 Computed by : MJO

Increment of stresses obtained using : Boussinesq

Settlement for X = 7.00 (ft) Y = 39.50 (ft)

Footing #	Corner Point P1		Corner Point P2		Load (psf)
	X1(ft)	Y1(ft)	X2(ft)	Y2(ft)	
1	7.00	32.00	33.00	37.00	90.00

Foundation Elev. = 117.00 (ft) Ground Surface Elev.= 132.50 (ft)
 Water table Elev. = 118.00 (ft) Unit weight of Wat. = 62.40 (pcf)

Nº.	Layer Type	Thick. (ft)	Comp. Ratio	Recomp. Ratio	Swell.	Unit Weight (pcf)	Primary Settlement (in.)	Secondary Settlement (in.)
1	INCOMP.	11.5				125.00	0.00	0.00
2	COMP.	43.0	0.250	0.037	0.037	118.00	0.11	0.00
3	INCOMP.	8.0				130.00	0.00	0.00
Total Settlement =							0.11	0.00

N§.	Sublayer		Soil Stresses			Settlement (in.)
	Thick. (ft)	Elev. (ft)	Initial (psf)	Increment (psf)	Max.Past Press. (psf)	
1	INCOMP.					
2	0.30	116.85	1855.44	0.00	1855.44	0.00
3	4.30	114.55	1983.32	3.65	1983.32	0.01
4	4.30	110.25	2222.40	9.35	2222.40	0.02
5	4.30	105.95	2461.48	8.81	2461.48	0.02
6	4.30	101.65	2700.56	7.33	2700.56	0.02
7	4.30	97.35	2939.64	5.99	2939.64	0.01
8	4.30	93.05	3178.72	4.91	3178.72	0.01
9	4.30	88.75	3417.80	4.06	3417.80	0.01
10	4.30	84.45	3656.88	3.39	3656.88	0.01
11	4.30	80.15	3895.96	2.86	3895.96	0.00
12	INCOMP.					
Total Settlement =						0.11 (in.)

RECTANGULAR LOADS

Project Name: North St Culvert, Agawam Project Number : 177018.00
 Client : Woodard-Curran Project Manager: MJO
 Date : 4/6/2023 Computed by : MJO

Increment of stresses obtained using : Boussinesq

Settlement for X = 18.00 (ft) Y = 37.00 (ft)

Footing #	Corner Point P1		Corner Point P2		Load (psf)
	X1(ft)	Y1(ft)	X2(ft)	Y2(ft)	
1	7.00	32.00	33.00	37.00	90.00

Foundation Elev. = 117.00 (ft) Ground Surface Elev.= 132.50 (ft)
 Water table Elev. = 118.00 (ft) Unit weight of Wat. = 62.40 (pcf)

Nº.	Layer Type	Thick. (ft)	Comp. Ratio	Recomp. Ratio	Swell. Ratio	Unit Weight (pcf)	Primary Settlement (in.)	Secondary Settlement (in.)
1	INCOMP.	11.5				125.00	0.00	0.00
2	COMP.	43.0	0.250	0.037	0.037	118.00	0.34	0.00
3	INCOMP.	8.0				130.00	0.00	0.00
Total Settlement =							0.34	0.00

N§.	Sublayer		Soil Stresses			Settlement (in.)
	Thick. (ft)	Elev. (ft)	Initial (psf)	Increment (psf)	Max.Past Press. (psf)	
1	INCOMP.					
2	0.30	116.85	1855.44	45.00	1855.44	0.01
3	4.30	114.55	1983.32	43.21	1983.32	0.12
4	4.30	110.25	2222.40	31.13	2222.40	0.08
5	4.30	105.95	2461.48	20.83	2461.48	0.05
6	4.30	101.65	2700.56	14.33	2700.56	0.03
7	4.30	97.35	2939.64	10.24	2939.64	0.02
8	4.30	93.05	3178.72	7.59	3178.72	0.01
9	4.30	88.75	3417.80	5.80	3417.80	0.01
10	4.30	84.45	3656.88	4.56	3656.88	0.01
11	4.30	80.15	3895.96	3.66	3895.96	0.01
12	INCOMP.					
Total Settlement =						0.34 (in.)

RECTANGULAR LOADS

Project Name: North St Culvert, Agawam Project Number : 177018.00
 Client : Woodard-Curran Project Manager: MJO
 Date : 4/6/2023 Computed by : MJO

Increment of stresses obtained using : Boussinesq

Settlement for X = 18.00 (ft) Y = 47.50 (ft)

Footing #	Corner Point P1		Corner Point P2		Load (psf)
	X1(ft)	Y1(ft)	X2(ft)	Y2(ft)	
1	7.00	32.00	33.00	37.00	90.00

Foundation Elev. = 117.00 (ft) Ground Surface Elev.= 132.50 (ft)
 Water table Elev. = 118.00 (ft) Unit weight of Wat. = 62.40 (pcf)

Nº.	Layer Type	Thick. (ft)	Comp. Ratio	Recomp. Ratio	Swell.	Unit Weight (pcf)	Primary Settlement (in.)	Secondary Settlement (in.)
1	INCOMP.	11.5				125.00	0.00	0.00
2	COMP.	43.0	0.250	0.037	0.037	118.00	0.05	0.00
3	INCOMP.	8.0				130.00	0.00	0.00
Total Settlement =							0.05	0.00

N§.	Sublayer		Soil Stresses			Settlement (in.)
	Thick. (ft)	Elev. (ft)	Initial (psf)	Increment (psf)	Max.Past Press. (psf)	
1	INCOMP.					
2	0.30	116.85	1855.44	0.00	1855.44	0.00
3	4.30	114.55	1983.32	0.14	1983.32	0.00
4	4.30	110.25	2222.40	1.75	2222.40	0.00
5	4.30	105.95	2461.48	3.76	2461.48	0.01
6	4.30	101.65	2700.56	4.69	2700.56	0.01
7	4.30	97.35	2939.64	4.71	2939.64	0.01
8	4.30	93.05	3178.72	4.30	3178.72	0.01
9	4.30	88.75	3417.80	3.78	3417.80	0.01
10	4.30	84.45	3656.88	3.26	3656.88	0.00
11	4.30	80.15	3895.96	2.80	3895.96	0.00
12	INCOMP.					
Total Settlement =						0.05 (in.)

RECTANGULAR LOADS

Project Name: North St Culvert, Agawam Project Number : 177018.00
 Client : Woodard-Curran Project Manager: MJO
 Date : 4/6/2023 Computed by : MJO

Increment of stresses obtained using : Boussinesq

Settlement for X = 7.00 (ft) Y = 32.00 (ft)

Footing #	Corner Point P1		Corner Point P2		Load (psf)
	X1(ft)	Y1(ft)	X2(ft)	Y2(ft)	
1	2.80	28.00	7.00	36.00	371.00
2	29.00	28.00	33.00	36.00	371.00
3	3.00	36.00	7.00	43.00	186.00
4	29.00	36.00	33.00	43.00	186.00

Foundation Elev. = 126.50 (ft) Ground Surface Elev. = 132.50 (ft)
 Water table Elev. = 118.00 (ft) Unit weight of Wat. = 62.40 (pcf)

Nº.	Layer Type	Thick. (ft)	Comp. Ratio	Recomp. Ratio	Swell.	Unit Weight (pcf)	Primary Settlement (in.)	Secondary Settlement (in.)
1	INCOMP.	11.5				125.00	0.00	0.00
2	COMP.	43.0	0.037	0.037	0.037	118.00	0.09	0.00
3	INCOMP.	8.0				130.00	0.00	0.00
Total Settlement =							0.09	0.00

N§.	Sublayer		Soil Stresses			Settlement (in.)
	Thick. (ft)	Elev. (ft)	Initial (psf)	Increment (psf)	Max.Past Press. (psf)	
1	INCOMP.					
2	4.30	118.85	1691.20	77.33	1691.20	0.04
3	4.30	114.55	1983.32	43.19	1983.32	0.02
4	4.30	110.25	2222.40	27.62	2222.40	0.01
5	4.30	105.95	2461.48	19.55	2461.48	0.01
6	4.30	101.65	2700.56	14.83	2700.56	0.00
7	4.30	97.35	2939.64	11.77	2939.64	0.00
8	4.30	93.05	3178.72	9.63	3178.72	0.00
9	4.30	88.75	3417.80	8.05	3417.80	0.00
10	4.30	84.45	3656.88	6.83	3656.88	0.00
11	4.30	80.15	3895.96	5.87	3895.96	0.00
12	INCOMP.					

Total Settlement = 0.09 (in.)

RECTANGULAR LOADS

Project Name: North St Culvert, Agawam Project Number : 177018.00
 Client : Woodard-Curran Project Manager: MJO
 Date : 4/6/2023 Computed by : MJO

Increment of stresses obtained using : Boussinesq

Settlement for X = 7.00 (ft) Y = 39.50 (ft)

Footing #	Corner Point P1		Corner Point P2		Load (psf)
	X1(ft)	Y1(ft)	X2(ft)	Y2(ft)	
1	2.80	28.00	7.00	36.00	371.00
2	29.00	28.00	33.00	36.00	371.00
3	3.00	36.00	7.00	43.00	186.00
4	29.00	36.00	33.00	43.00	186.00

Foundation Elev. = 126.50 (ft) Ground Surface Elev.= 132.50 (ft)
 Water table Elev. = 118.00 (ft) Unit weight of Wat. = 62.40 (pcf)

Nº.	Layer Type	Thick. (ft)	Comp. Ratio	Recomp. Ratio	Swell.	Unit Weight (pcf)	Primary Settlement (in.)	Secondary Settlement (in.)
1	INCOMP.	11.5				125.00	0.00	0.00
2	COMP.	43.0	0.037	0.037	0.037	118.00	0.07	0.00
3	INCOMP.	8.0				130.00	0.00	0.00
Total Settlement =							0.07	0.00

N§.	Sublayer		Soil Stresses			Settlement (in.)
	Thick. (ft)	Elev. (ft)	Initial (psf)	Increment (psf)	Max.Past Press. (psf)	
1	INCOMP.					
2	4.30	118.85	1691.20	51.51	1691.20	0.02
3	4.30	114.55	1983.32	33.67	1983.32	0.01
4	4.30	110.25	2222.40	23.57	2222.40	0.01
5	4.30	105.95	2461.48	17.57	2461.48	0.01
6	4.30	101.65	2700.56	13.75	2700.56	0.00
7	4.30	97.35	2939.64	11.13	2939.64	0.00
8	4.30	93.05	3178.72	9.22	3178.72	0.00
9	4.30	88.75	3417.80	7.77	3417.80	0.00
10	4.30	84.45	3656.88	6.64	3656.88	0.00
11	4.30	80.15	3895.96	5.73	3895.96	0.00
12	INCOMP.					

Total Settlement = 0.07 (in.)

RECTANGULAR LOADS

Project Name: North St Culvert, Agawam Project Number : 177018.00
 Client : Woodard-Curran Project Manager: MJO
 Date : 4/6/2023 Computed by : MJO

Increment of stresses obtained using : Boussinesq

Settlement for X = 7.00 (ft) Y = 86.50 (ft)

Footing #	Corner Point P1		Corner Point P2		Load (psf)
	X1(ft)	Y1(ft)	X2(ft)	Y2(ft)	
1	2.80	28.00	7.00	36.00	371.00
2	29.00	28.00	33.00	36.00	371.00
3	3.00	36.00	7.00	43.00	186.00
4	29.00	36.00	33.00	43.00	186.00

Foundation Elev. = 126.50 (ft) Ground Surface Elev.= 132.50 (ft)
 Water table Elev. = 118.00 (ft) Unit weight of Wat. = 62.40 (pcf)

Nº.	Layer Type	Thick. (ft)	Comp. Ratio	Recomp. Ratio	Swell.	Unit Weight (pcf)	Primary Settlement (in.)	Secondary Settlement (in.)
1	INCOMP.	11.5				125.00	0.00	0.00
2	COMP.	43.0	0.037	0.037	0.037	118.00	0.00	0.00
3	INCOMP.	8.0				130.00	0.00	0.00
Total Settlement =							0.00	0.00

N§.	Sublayer		Soil Stresses			Settlement (in.)
	Thick. (ft)	Elev. (ft)	Initial (psf)	Increment (psf)	Max.Past Press. (psf)	
1	INCOMP.					
2	4.30	118.85	1691.20	0.02	1691.20	0.00
3	4.30	114.55	1983.32	0.06	1983.32	0.00
4	4.30	110.25	2222.40	0.13	2222.40	0.00
5	4.30	105.95	2461.48	0.23	2461.48	0.00
6	4.30	101.65	2700.56	0.35	2700.56	0.00
7	4.30	97.35	2939.64	0.47	2939.64	0.00
8	4.30	93.05	3178.72	0.60	3178.72	0.00
9	4.30	88.75	3417.80	0.71	3417.80	0.00
10	4.30	84.45	3656.88	0.81	3656.88	0.00
11	4.30	80.15	3895.96	0.89	3895.96	0.00
12	INCOMP.					

Total Settlement = 0.00 (in.)

RECTANGULAR LOADS

Project Name: North St Culvert, Agawam Project Number : 177018.00
 Client : Woodard-Curran Project Manager: MJO
 Date : 4/6/2023 Computed by : MJO

Increment of stresses obtained using : Boussinesq

Settlement for X = 18.00 (ft) Y = 37.00 (ft)

Footing #	Corner Point P1		Corner Point P2		Load (psf)
	X1(ft)	Y1(ft)	X2(ft)	Y2(ft)	
1	2.80	28.00	7.00	36.00	371.00
2	29.00	28.00	33.00	36.00	371.00
3	3.00	36.00	7.00	43.00	186.00
4	29.00	36.00	33.00	43.00	186.00

Foundation Elev. = 126.50 (ft) Ground Surface Elev.= 132.50 (ft)
 Water table Elev. = 118.00 (ft) Unit weight of Wat. = 62.40 (pcf)

Nº.	Layer Type	Thick. (ft)	Comp. Ratio	Recomp. Ratio	Swell.	Unit Weight (pcf)	Primary Settlement (in.)	Secondary Settlement (in.)
1	INCOMP.	11.5				125.00	0.00	0.00
2	COMP.	43.0	0.037	0.037	0.037	118.00	0.04	0.00
3	INCOMP.	8.0				130.00	0.00	0.00
Total Settlement =							0.04	0.00

N§.	Sublayer		Soil Stresses			Settlement (in.)
	Thick. (ft)	Elev. (ft)	Initial (psf)	Increment (psf)	Max.Past Press. (psf)	
1	INCOMP.					
2	4.30	118.85	1691.20	7.96	1691.20	0.00
3	4.30	114.55	1983.32	14.20	1983.32	0.01
4	4.30	110.25	2222.40	16.19	2222.40	0.01
5	4.30	105.95	2461.48	15.42	2461.48	0.01
6	4.30	101.65	2700.56	13.63	2700.56	0.00
7	4.30	97.35	2939.64	11.70	2939.64	0.00
8	4.30	93.05	3178.72	9.95	3178.72	0.00
9	4.30	88.75	3417.80	8.46	3417.80	0.00
10	4.30	84.45	3656.88	7.23	3656.88	0.00
11	4.30	80.15	3895.96	6.22	3895.96	0.00
12	INCOMP.					

Total Settlement = 0.04 (in.)

RECTANGULAR LOADS

Project Name: North St Culvert, Agawam Project Number : 177018.00
 Client : Woodard-Curran Project Manager: MJO
 Date : 4/6/2023 Computed by : MJO

Increment of stresses obtained using : Boussinesq

Settlement for X = 18.00 (ft) Y = 47.50 (ft)

Footing #	Corner Point P1		Corner Point P2		Load (psf)
	X1(ft)	Y1(ft)	X2(ft)	Y2(ft)	
1	2.80	28.00	7.00	36.00	371.00
2	29.00	28.00	33.00	36.00	371.00
3	3.00	36.00	7.00	43.00	186.00
4	29.00	36.00	33.00	43.00	186.00

Foundation Elev. = 126.50 (ft) Ground Surface Elev.= 132.50 (ft)
 Water table Elev. = 118.00 (ft) Unit weight of Wat. = 62.40 (pcf)

Nº.	Layer Type	Thick. (ft)	Comp. Ratio	Recomp. Ratio	Swell.	Unit Weight (pcf)	Primary Settlement (in.)	Secondary Settlement (in.)
1	INCOMP.	11.5				125.00	0.00	0.00
2	COMP.	43.0	0.037	0.037	0.037	118.00	0.02	0.00
3	INCOMP.	8.0				130.00	0.00	0.00
Total Settlement =							0.02	0.00

N§.	Sublayer		Soil Stresses			Settlement (in.)
	Thick. (ft)	Elev. (ft)	Initial (psf)	Increment (psf)	Max.Past Press. (psf)	
1	INCOMP.					
2	4.30	118.85	1691.20	2.81	1691.20	0.00
3	4.30	114.55	1983.32	6.09	1983.32	0.00
4	4.30	110.25	2222.40	8.26	2222.40	0.00
5	4.30	105.95	2461.48	9.05	2461.48	0.00
6	4.30	101.65	2700.56	8.91	2700.56	0.00
7	4.30	97.35	2939.64	8.30	2939.64	0.00
8	4.30	93.05	3178.72	7.51	3178.72	0.00
9	4.30	88.75	3417.80	6.70	3417.80	0.00
10	4.30	84.45	3656.88	5.95	3656.88	0.00
11	4.30	80.15	3895.96	5.27	3895.96	0.00
12	INCOMP.					

Total Settlement = 0.02 (in.)

RECTANGULAR LOADS

Project Name: North St Culvert, Agawam Project Number : 177018.00
 Client : Woodard-Curran Project Manager: MJO
 Date : 4/6/2023 Computed by : MJO

Increment of stresses obtained using : Boussinesq

Settlement for X = 18.00 (ft) Y = 86.50 (ft)

Footing #	Corner Point P1		Corner Point P2		Load (psf)
	X1(ft)	Y1(ft)	X2(ft)	Y2(ft)	
1	2.80	28.00	7.00	36.00	371.00
2	29.00	28.00	33.00	36.00	371.00
3	3.00	36.00	7.00	43.00	186.00
4	29.00	36.00	33.00	43.00	186.00

Foundation Elev. = 126.50 (ft) Ground Surface Elev.= 132.50 (ft)
 Water table Elev. = 118.00 (ft) Unit weight of Wat. = 62.40 (pcf)

Nº.	Layer Type	Thick. (ft)	Comp. Ratio	Recomp. Ratio	Swell.	Unit Weight (pcf)	Primary Settlement (in.)	Secondary Settlement (in.)
1	INCOMP.	11.5				125.00	0.00	0.00
2	COMP.	43.0	0.037	0.037	0.037	118.00	0.00	0.00
3	INCOMP.	8.0				130.00	0.00	0.00
Total Settlement =							0.00	0.00

N§.	Sublayer		Soil Stresses			Settlement (in.)
	Thick. (ft)	Elev. (ft)	Initial (psf)	Increment (psf)	Max.Past Press. (psf)	
1	INCOMP.					
2	4.30	118.85	1691.20	0.02	1691.20	0.00
3	4.30	114.55	1983.32	0.06	1983.32	0.00
4	4.30	110.25	2222.40	0.14	2222.40	0.00
5	4.30	105.95	2461.48	0.24	2461.48	0.00
6	4.30	101.65	2700.56	0.37	2700.56	0.00
7	4.30	97.35	2939.64	0.50	2939.64	0.00
8	4.30	93.05	3178.72	0.63	3178.72	0.00
9	4.30	88.75	3417.80	0.75	3417.80	0.00
10	4.30	84.45	3656.88	0.85	3656.88	0.00
11	4.30	80.15	3895.96	0.93	3895.96	0.00
12	INCOMP.					

Total Settlement = 0.00 (in.)



Seismic Site Class Calculation

Project: North Street over White Brook - Culvert Replacement
Location: Agawam, MA
Calculated By: MJO **Date:** 2/3/2023
Checked By: JBH **Date:** 3/31/2023
Revised By: _____ **Date:** _____
Checked By: _____ **Date:** _____

Objective: Determine seismic site class & seismic design parameters for the replacement culvert (proposed aluminum arch culvert) in accordance with MassDOT LRFD Bridge Design Manual, which references the AASHTO Guide Specifications for LRFD Seismic Bridge Design (2nd edition, 2011 with interim revisions).

Subsurface Information: Recent borings BB-1 through BB-3 performed between December 28 and 30, 2022 by Seaboard Drilling, Inc., observed and logged by GZA. Also includes select information from previous borings WB-1 and WB-2 performed on November 12, 2020, observed and logged by O'Reilly, Talbot & Okun Engineering Associates (OTO) because the recent borings were performed using drive and wash techniques and the previous borings were performed with hollow-stem-auger techniques.

- Approach:**
- 1) Assess if site conditions are known in sufficient detail to establish site class. If not, an assumption of Site Class D is permitted unless conditions for Site Class E or F are established.
 - 2) Check for the four categories of Site Class F requiring site-specific evaluation:
 - Soils vulnerable to potential failure (liquefiable soils, sensitive clays, weakly cemented soils)
 - Peats or highly organic clays greater than 10 feet in thickness
 - Thick layers (greater than 25 feet) of highly plastic clay ($PI > 75$)
 - Very thick soft/medium stiff clays (greater than 125 feet)
 - 3) Check for existence of greater than 10 feet of soft clay (where $s_u < 500$ psf, $w > 40\%$, and $PI > 20$). If these conditions are met, classify as Site Class E.
(NOTE: FOR THIS SITE, THE ABOVE CONDITIONS ARE NOT MET)
 - 4) Categorize the site using the V_s , \bar{N} , or $\sigma'_v s_u$ methods.
 - 5) Determine the appropriate Site Class based on the boring-specific results. If appropriate, split the site into two or more different site classes.
 - 6) North Street is not on or over any of the National Highway System (NHS) routes, therefore the proposed culvert replacement is not considered a critical/essential bridge. Therefore, use the AASHTO LRFD Seismic Bridge Design Manual, 2011 to calculate SD_1 , SD_5 , and A_s .

Site Class Results per Boring: For the purpose of this calculation, SPT N-values obtained from recent borings BB-1 through BB-3 and select SPT N-values from previous borings WB-1 and WB-2, which did not overlap with samples from recent borings BB-2 and BB-3, were

Exploration	N	Site Class per Boring
BB-1	11.0	E
BB-2	8.0	E
BB-3	5.9	E

Site Class: Based on the above, we recommend the site be classified as Site Class E.



Seismic Site Class Calculation

Project: North Street over White Brook - Culvert Replacement
Location: Agawam, MA
Calculated By: MJO **Date:** 2/3/2023
Checked By: JBH **Date:** 3/31/2023
Revised By: _____ **Date:** _____
Checked By: _____ **Date:** _____

Seismic Design Parameters:

Based on the criteria specified in the MassDOT LRFD Bridge Manual, the culvert structure is considered a non-critical/non-essential, conventional bridge. Therefore, seismic design parameters may be developed using the hazard maps contained in AASHTO LRFD Seismic, which are based on a 1,000-year return period event.

$$\begin{array}{llll}
 S_1 = 0.038 & S_{D1} = & 0.133 & S_{D1} = F_v S_1 \text{ (AASHTO Eq 3.4.1-3)} \\
 S_s = 0.131 & S_{DS} = & 0.328 & S_{DS} = F_a S_s \text{ (AASHTO Eq 3.4.1-2)} \\
 PGA = 0.059 & PGA = & 0.148 & A_s = F_{pga} PGA \text{ (AASHTO Eq 3.4.1-1)}
 \end{array}$$

$$\begin{array}{lll}
 F_v = & 3.5 & \text{(AASHTO Table 3.4.2.3-2)} \\
 F_a = & 2.5 & \text{(AASHTO Table 3.4.2.3-1)} \\
 F_{pga} = & 2.5 & \text{(AASHTO Table 3.4.2.3-1)}
 \end{array}$$

AASHTO Table 3.4.2.1-1 - Site Class Definitions

Site Class	Soil Type and Profile
A	Hard rock with measured shear wave velocity, $\bar{v}_s > 5,000$ ft/s
B	Rock with $2,500$ ft/sec $< \bar{v}_s < 5,000$ ft/s
C	Very dense soil and soil rock with $1,200$ ft/sec $< \bar{v}_s < 2,500$ ft/s, or with either $\bar{N} > 50$ blows/ft, or $\bar{s}_u > 2.0$ ksf
D	Stiff soil with 600 ft/s $< \bar{v}_s < 1,200$ ft/s, or with either $15 < \bar{N} < 50$ blows/ft, or $1.0 < \bar{s}_u < 2.0$ ksf
E	Soil profile with $\bar{v}_s < 600$ ft/s or with either $\bar{N} < 15$ blows/ft or $\bar{s}_u < 1.0$ ksf, or any profile with more than 10 ft of soft clay defined as soil with $PI > 20$, $w > 40$ percent and $\bar{s}_u < 0.5$ ksf
F	Soils requiring site-specific evaluations, such as: <ul style="list-style-type: none"> • Peats or highly organic clays ($H > 10$ ft of peat or highly organic clay where H = thickness of soil) • Very high plasticity clays ($H > 25$ ft with $PI > 75$) • Very thick soft/medium stiff clays ($H > 120$ ft)

Attachments:

Seismic parameters from the USGS.gov designmaps web analysis tool based on the site location and site class

INPUT

Exploration ID: BB-1 Ground Surface Elevation: 136.5 Depth of Boring: 52.5 ft
 Depth to Bedrock: 42.5 ft

EQUATIONS

$$\bar{N} = \frac{\sum_{i=1}^m d_i}{\sum_{i=1}^m \frac{d_i}{N_i}}$$

m = number of layers
 d_i = the thickness of any soil or rock layer between 0 and 100 feet.
 N_i = the Standard Penetration Resistance (ASTM D 1586) not to exceed 100 blows/ft as directly measured in the field without corrections.
 Note: d_i calculated assuming breaks between sub-layers occur at the midpoint between SPT sample intervals (unless noted otherwise).

CALCULATION

$$\bar{N} = 11.0$$

Soil Strata	SPT Interval Depth		SPT Elevation (mid-interval)	SPT N-value	d _i (ft)	d _i / N _i	Comments
	Top, ft	Bottom, ft					
Fill	0.0	2.0	135.5	9	2.0	0.222	N=100 assumed for bedrock
	2.0	4.0	133.5	4	2.0	0.500	
	4.0	6.0	131.5	6	2.0	0.333	
	6.0	8.0	129.5	6	2.0	0.333	
	8.0	10.0	127.5	6	2.0	0.333	
	10.0	12.0	125.5	8	2.5	0.313	
SILT/CLAY	13.0	15.0	122.5	6	4.0	0.667	
	18.0	20.0	117.5	4	5.0	1.250	
	23.0	25.0	112.5	5	5.0	1.000	
	28.0	30.0	107.5	2	5.0	2.500	
GLACIAL TILL	33.0	35.0	102.5	7	3.5	0.500	
	35.0	37.0	100.5	10	3.5	0.350	
	40.0	42.0	95.5	21	4.0	0.190	
Bedrock	42.5	100.0	65.3	100	57.5	0.575	

DATA VALIDATION

∑d_i = 100.0 

INPUT

Exploration ID: **BB-2/WB-1**

Ground Surface Elevation: **135.0**

Depth of Boring: **56.8** ft

Depth to Bedrock: **53.8** ft

EQUATIONS

$$\bar{N} = \frac{\sum_{i=1}^m d_i}{\sum_{i=1}^m N_i}$$

m = number of layers
 d_i = the thickness of any soil or rock layer between 0 and 100 feet.
 N_i = the Standard Penetration Resistance (ASTM D 1586) not to exceed 100 blows/ft as directly measured in the field without corrections.
 Note: d_i calculated assuming breaks between sub-layers occur at the midpoint between SPT sample intervals (unless noted otherwise).

CALCULATION

$$\bar{N} = 8.0$$

Soil Strata	SPT Interval Depth		SPT Elevation (mid-interval)	SPT N-value	d _i (ft)	d _i / N _i	Comments
	Top, ft	Bottom, ft					
FILL	0.5	2.5	133.5	35	3.8	0.107	Blow count from BB-02
	5.0	7.0	129.0	5	4.8	0.950	Blow count from WB-1
	10.0	12.0	124.0	9	4.0	0.444	Blow count from WB-1
	13.0	15.0	121.0	6	4.0	0.667	Blow count from BB-02
SILT/CLAY	18.0	20.0	116.0	3	5.0	1.667	Blow count from BB-02
	23.0	25.0	111.0	3	5.0	1.667	Blow count from BB-02
	28.0	30.0	106.0	2	5.0	2.500	Blow count from BB-02
	33.0	35.0	101.0	7	5.0	0.714	Blow count from BB-02
	38.0	40.0	96.0	8	5.0	0.625	Blow count from BB-02
	43.0	45.0	91.0	5	5.0	1.000	Blow count from BB-02
	48.0	50.0	86.0	3	5.0	1.667	Blow count from BB-02
Glacial Till	53.0	53.8	81.6	100	2.3	0.023	Blow count from BB-02
Bedrock	53.8	100.0	58.1	100	46.2	0.462	N=100 assumed for bedrock

DATA VALIDATION

Σd _i =	100.0	✓
-------------------	-------	---

INPUT

Exploration ID: BB-3/WB-2

Ground Surface Elevation: 132.5

Depth of Boring: 66.5 ft

Depth to Bedrock: 62.5 ft

EQUATIONS

$$\bar{N} = \frac{\sum_{i=1}^m d_i}{\sum_{i=1}^m N_i}$$

m = number of layers
 d_i = the thickness of any soil or rock layer between 0 and 100 feet.
 N_i = the Standard Penetration Resistance (ASTM D 1586) not to exceed 100 blows/ft as directly measured in the field without corrections.
 Note: d_i calculated assuming breaks between sub-layers occur at the midpoint between SPT sample intervals (unless noted otherwise).

CALCULATION

$$\bar{N} = 5.9$$

Soil Strata	SPT Interval Depth		SPT Elevation (mid-interval)	SPT N-value	d _i (ft)	d _i / N _i	Comments
	Top, ft	Bottom, ft					
FILL	0.0	2.0	131.5	35	3.5	0.100	Blow count from BB-03
	5.0	7.0	126.5	2	5.0	2.500	Blow count from WB-2
	10.0	12.0	121.5	6	4.0	0.667	Blow count from WB-2
	13.0	15.0	118.5	16	2.5	0.156	Blow count from BB-03
SILT/CLAY	15.0	17.0	116.5	3	3.5	1.167	Blow count from WB-2
	20.0	22.0	111.5	2	4.0	2.000	Blow count from WB-2
	23.0	25.0	108.5	2	2.5	1.250	Blow count from BB-03
	25.0	27.0	106.5	4	5.0	1.250	Blow count from BB-03
	33.0	35.0	98.5	2	9.0	4.500	Blow count from BB-03
	43.0	45.0	88.5	5	10.0	2.000	Blow count from BB-03
	53.0	55.0	78.5	13	13.5	1.038	Blow count from BB-03
Bedrock	62.5	100.0	51.3	100	37.5	0.375	N=100 assumed for bedrock

DATA VALIDATION

Σd _i =	100.0	✔
-------------------	-------	---

```
{
  "request": {
    "date": "2023-02-07T17:13:59.798Z",
    "referenceDocument": "AASHTO-2009",
    "status": "success",
    "url": "https://earthquake.usgs.gov/ws/designmaps/aashto-2009.json?
latitude=42.081&longitude=-72.663&siteClass=E&title=NorthStreet",
    "parameters": {
      "latitude": 42.081,
      "longitude": -72.663,
      "siteClass": "E",
      "title": "NorthStreet"
    }
  },
  "response": {
    "data": {
      "pga": 0.059,
      "fpga": 2.5,
      "as": 0.148,
      "ss": 0.13,
      "fa": 2.5,
      "sds": 0.326,
      "s1": 0.038,
      "fv": 3.5,
      "sd1": 0.132,
      "sdc": "A",
      "ts": 0.405,
      "t0": 0.081,
      "twoPeriodDesignSpectrum": [
        [
          0,
          0.148
        ],
        [
          0.025,
          0.203
        ],
        [
          0.05,
          0.258
        ],
        [
          0.081,
          0.326
        ],
        [
          0.1,
          0.326
        ],
        [
          0.15,
          0.326
        ],
        [
          0.2,
          0.326
        ],
        [
          0.25,
          0.326
        ],
        [
          0.3,
          0.326
        ]
      ]
    }
  }
}
```

```
],  
[  
  0.35,  
  0.326  
],  
[  
  0.4,  
  0.326  
],  
[  
  0.405,  
  0.326  
],  
[  
  0.45,  
  0.294  
],  
[  
  0.5,  
  0.264  
],  
[  
  0.55,  
  0.24  
],  
[  
  0.6,  
  0.22  
],  
[  
  0.65,  
  0.203  
],  
[  
  0.7,  
  0.189  
],  
[  
  0.75,  
  0.176  
],  
[  
  0.8,  
  0.165  
],  
[  
  0.85,  
  0.156  
],  
[  
  0.9,  
  0.147  
],  
[  
  0.95,  
  0.139  
],  
[  
  1,  
  0.132  
],  
[  
  1.05,  
  0.126  
],  
],
```



```
[
  1.1,
  0.12
],
[
  1.15,
  0.115
],
[
  1.2,
  0.11
],
[
  1.25,
  0.106
],
[
  1.3,
  0.102
],
[
  1.35,
  0.098
],
[
  1.4,
  0.094
],
[
  1.45,
  0.091
],
[
  1.5,
  0.088
],
[
  1.55,
  0.085
],
[
  1.6,
  0.083
],
[
  1.65,
  0.08
],
[
  1.7,
  0.078
],
[
  1.75,
  0.076
],
[
  1.8,
  0.073
],
[
  1.85,
  0.071
],
[
```

1.9,
0.07
],
[
1.95,
0.068
],
[
2,
0.066
],
[
2.05,
0.064
],
[
2.1,
0.063
],
[
2.15,
0.061
],
[
2.2,
0.06
],
[
2.25,
0.059
],
[
2.3,
0.057
],
[
2.35,
0.056
],
[
2.4,
0.055
],
[
2.45,
0.054
],
[
2.5,
0.053
],
[
2.55,
0.052
],
[
2.6,
0.051
],
[
2.65,
0.05
],
[
2.7,

0.049
],
[
2.75,
0.048
],
[
2.8,
0.047
],
[
2.85,
0.046
],
[
2.9,
0.046
],
[
2.95,
0.045
],
[
3,
0.044
],
[
3.05,
0.043
],
[
3.1,
0.043
],
[
3.15,
0.042
],
[
3.2,
0.041
],
[
3.25,
0.041
],
[
3.3,
0.04
],
[
3.35,
0.039
],
[
3.4,
0.039
],
[
3.45,
0.038
],
[
3.5,
0.038

```
    ],
    [
      3.55,
      0.037
    ],
    [
      3.6,
      0.037
    ],
    [
      3.65,
      0.036
    ],
    [
      3.7,
      0.036
    ],
    [
      3.75,
      0.035
    ],
    [
      3.8,
      0.035
    ],
    [
      3.85,
      0.034
    ],
    [
      3.9,
      0.034
    ],
    [
      3.95,
      0.033
    ],
    [
      4,
      0.033
    ]
  ]
},
"metadata": {
  "griddedValuesID": "2002-US-AASHTO-05-050-R1.rnd",
  "spatialInterpolationMethod": "linearlinearlinear"
}
}
```

**APPENDIX G ATTACHMENT 1
PROPOSED CULVERT PLAN VIEW SKETCH**

**SOURCE: PRELIMINARY DESIGN PLAN PREPARED BY
WOODARD & CURRAN ENTITLED "SITE LAYOUT PLAN,"
DATED FEBRUARY 16, 2023.**

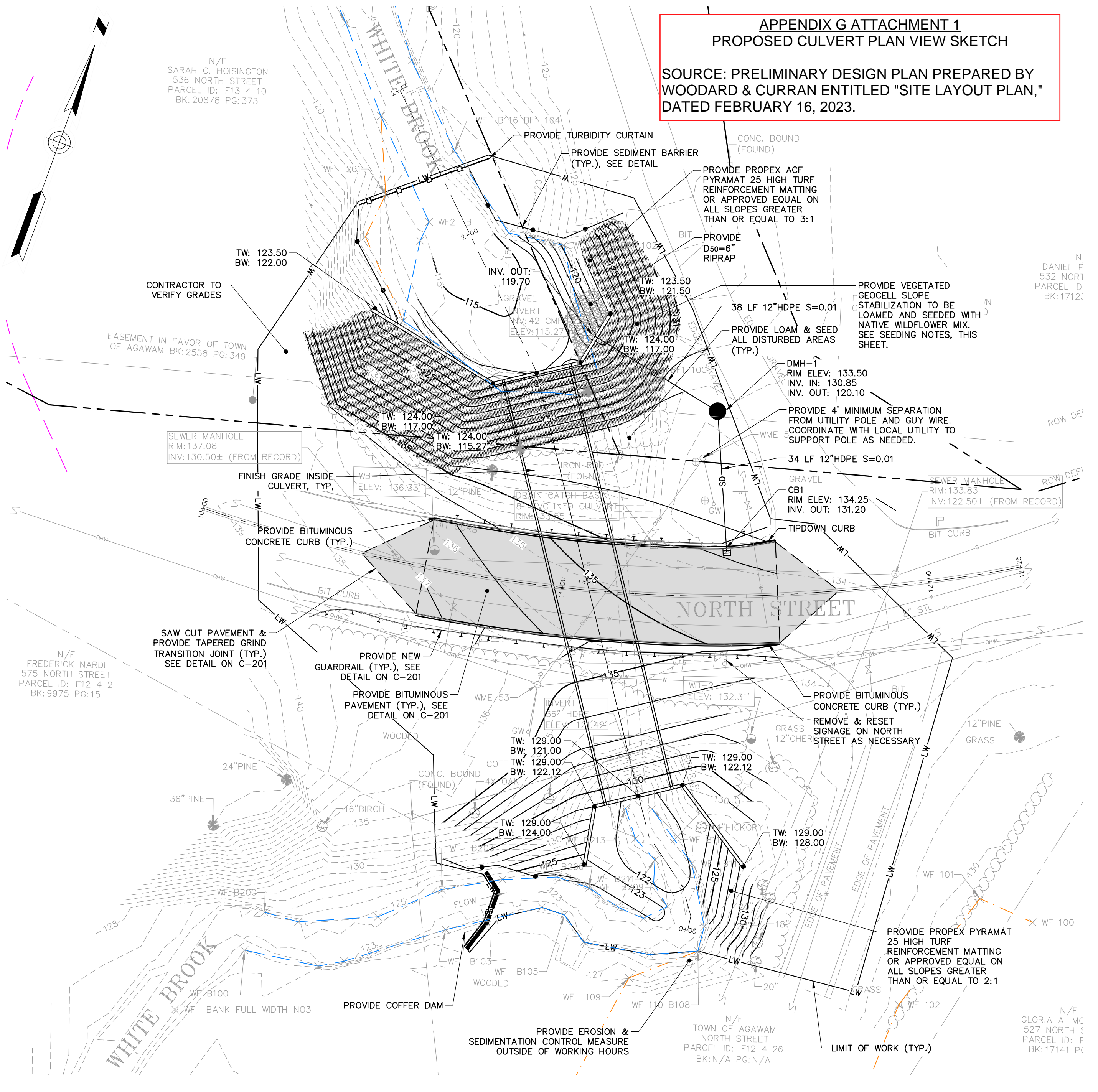

N/F
SARAH C. HOISINGTON
536 NORTH STREET
PARCEL ID: F13 4 10
BK: 20878 PG: 373

N
DANIEL F
532 NOR
PARCEL ID
BK: 1712:

EASEMENT IN FAVOR OF TOWN
OF AGAWAM BK: 2558 PG: 349

SEWER MANHOLE
RIM: 137.08
INV: 130.50± (FROM RECORD)

SEWER MANHOLE
RIM: 133.83
INV: 122.50± (FROM RECORD)

N/F
FREDERICK NARDI
575 NORTH STREET
PARCEL ID: F12 4 2
BK: 9975 PG: 15

N/F
TOWN OF AGAWAM
NORTH STREET
PARCEL ID: F12 4 26
BK: N/A PG: N/A

N/F
GLORIA A. MC
527 NORTH S
PARCEL ID: F
BK: 17141 P

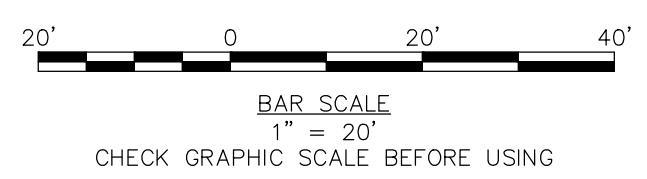

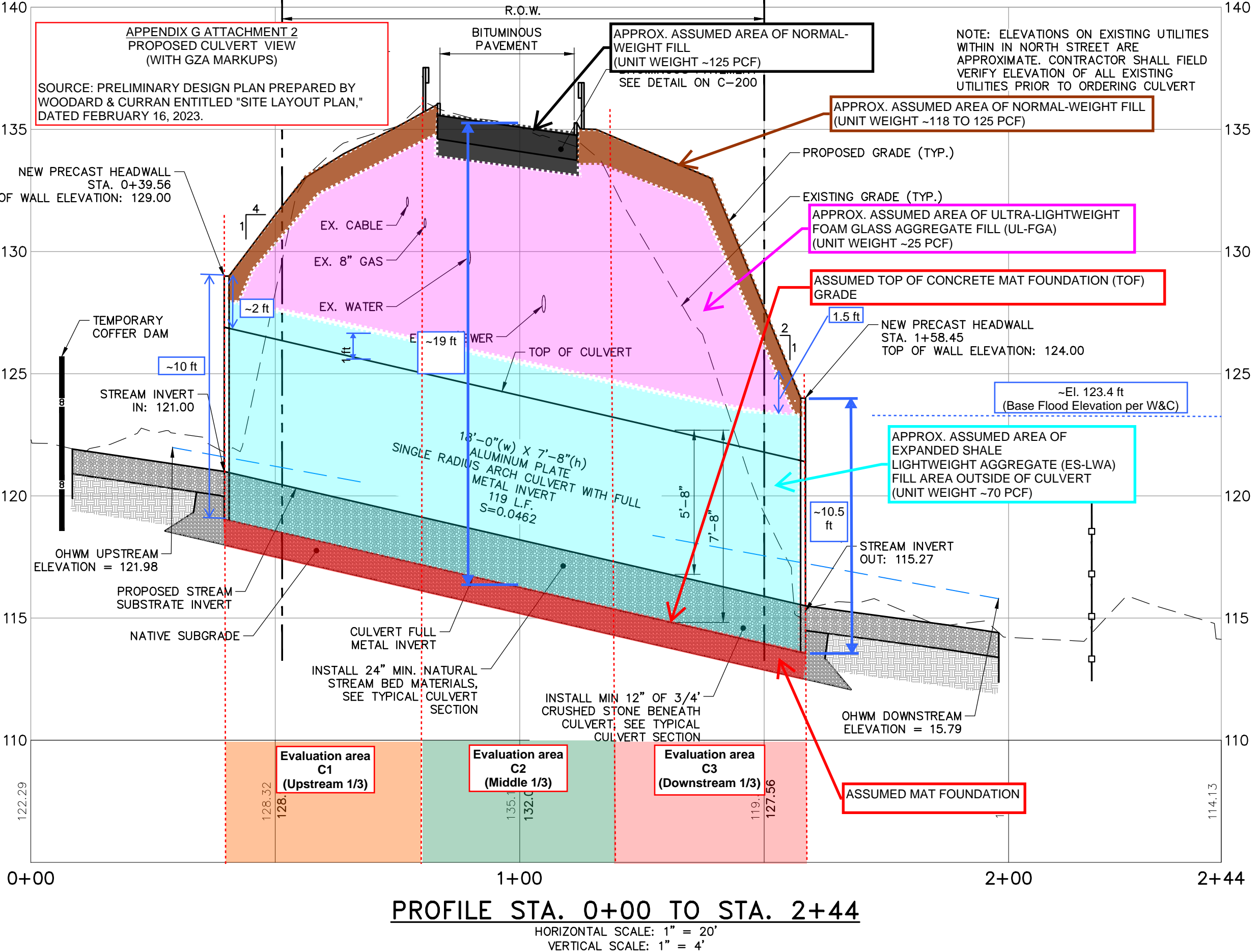

**APPENDIX G ATTACHMENT 2
PROPOSED CULVERT VIEW
(WITH GZA MARKUPS)**

SOURCE: PRELIMINARY DESIGN PLAN PREPARED BY WOODARD & CURRAN ENTITLED "SITE LAYOUT PLAN," DATED FEBRUARY 16, 2023.

APPROX. ASSUMED AREA OF NORMAL-WEIGHT FILL (UNIT WEIGHT ~125 PCF)
SEE DETAIL ON C-200

NOTE: ELEVATIONS ON EXISTING UTILITIES WITHIN IN NORTH STREET ARE APPROXIMATE. CONTRACTOR SHALL FIELD VERIFY ELEVATION OF ALL EXISTING UTILITIES PRIOR TO ORDERING CULVERT

APPROX. ASSUMED AREA OF NORMAL-WEIGHT FILL (UNIT WEIGHT ~118 TO 125 PCF)

APPROX. ASSUMED AREA OF ULTRA-LIGHTWEIGHT FOAM GLASS AGGREGATE FILL (UL-FGA) (UNIT WEIGHT ~25 PCF)

ASSUMED TOP OF CONCRETE MAT FOUNDATION (TOF) GRADE

APPROX. ASSUMED AREA OF EXPANDED SHALE LIGHTWEIGHT AGGREGATE (ES-LWA) FILL AREA OUTSIDE OF CULVERT (UNIT WEIGHT ~70 PCF)

ASSUMED MAT FOUNDATION

NEW PRECAST HEADWALL
STA. 0+39.56
TOP OF WALL ELEVATION: 129.00

NEW PRECAST HEADWALL
STA. 1+58.45
TOP OF WALL ELEVATION: 124.00

TEMPORARY COFFER DAM

STREAM INVERT
IN: 121.00

STREAM INVERT
OUT: 115.27

OHWM UPSTREAM
ELEVATION = 121.98

OHWM DOWNSTREAM
ELEVATION = 15.79

PROPOSED STREAM
SUBSTRATE INVERT

NATIVE SUBGRADE

CULVERT FULL
METAL INVERT

INSTALL 24" MIN. NATURAL
STREAM BED MATERIALS,
SEE TYPICAL CULVERT
SECTION

INSTALL MIN 12" OF 3/4'
CRUSHED STONE BENEATH
CULVERT. SEE TYPICAL
CULVERT SECTION

Evaluation area
C1
(Upstream 1/3)

Evaluation area
C2
(Middle 1/3)

Evaluation area
C3
(Downstream 1/3)

18'-0"(w) X 7'-8"(h)
SINGLE RADIUS ARCH CULVERT WITH FULL
ALUMINUM PLATE
METAL INVERT
119 L.F.
S=0.0462

R.O.W.
BITUMINOUS
PAVEMENT

EX. CABLE

EX. 8" GAS

EX. WATER

EX. ~19" SEWER

TOP OF CULVERT

PROPOSED GRADE (TYP.)

EXISTING GRADE (TYP.)

1.5 ft

~10.5 ft

~2 ft

~10 ft

5'-8"

7'-8"

1 ft

2

1

4

1

1

1

1

1

1

1

PROFILE STA. 0+00 TO STA. 2+44

HORIZONTAL SCALE: 1" = 20'
VERTICAL SCALE: 1" = 4'

0+00 1+00 2+00 2+44

122.29 128.32 128.1 135.1 132.0 119.1 127.56 114.13

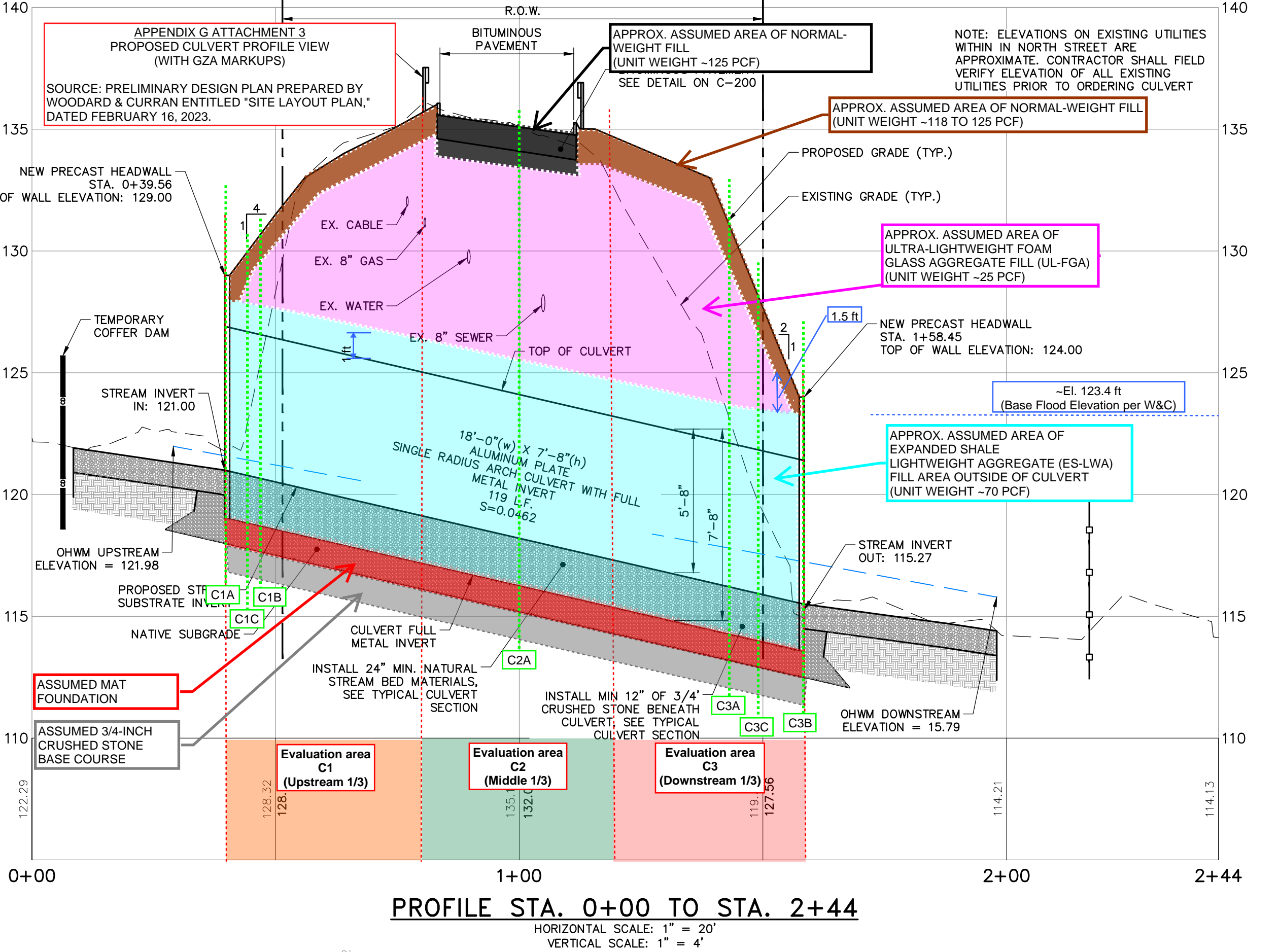

APPENDIX G ATTACHMENT 3
 PROPOSED CULVERT PROFILE VIEW
 (WITH GZA MARKUPS)

SOURCE: PRELIMINARY DESIGN PLAN PREPARED BY
 WOODARD & CURRAN ENTITLED "SITE LAYOUT PLAN,"
 DATED FEBRUARY 16, 2023.

APPROX. ASSUMED AREA OF NORMAL-
 WEIGHT FILL
 (UNIT WEIGHT ~125 PCF)
 SEE DETAIL ON C-200

NOTE: ELEVATIONS ON EXISTING UTILITIES
 WITHIN IN NORTH STREET ARE
 APPROXIMATE. CONTRACTOR SHALL FIELD
 VERIFY ELEVATION OF ALL EXISTING
 UTILITIES PRIOR TO ORDERING CULVERT

APPROX. ASSUMED AREA OF NORMAL-WEIGHT FILL
 (UNIT WEIGHT ~118 TO 125 PCF)

APPROX. ASSUMED AREA OF
 ULTRA-LIGHTWEIGHT FOAM
 GLASS AGGREGATE FILL (UL-FGA)
 (UNIT WEIGHT ~25 PCF)

APPROX. ASSUMED AREA OF
 EXPANDED SHALE
 LIGHTWEIGHT AGGREGATE (ES-LWA)
 FILL AREA OUTSIDE OF CULVERT
 (UNIT WEIGHT ~70 PCF)

ASSUMED MAT
 FOUNDATION

ASSUMED 3/4-INCH
 CRUSHED STONE
 BASE COURSE

Evaluation area
 C1
 (Upstream 1/3)

Evaluation area
 C2
 (Middle 1/3)

Evaluation area
 C3
 (Downstream 1/3)

PROFILE STA. 0+00 TO STA. 2+44

HORIZONTAL SCALE: 1" = 20'
 VERTICAL SCALE: 1" = 4'

NEW PRECAST HEADWALL
 STA. 0+39.56
 OF WALL ELEVATION: 129.00

NEW PRECAST HEADWALL
 STA. 1+58.45
 TOP OF WALL ELEVATION: 124.00

~El. 123.4 ft
 (Base Flood Elevation per W&C)

STREAM INVERT
 IN: 121.00

STREAM INVERT
 OUT: 115.27

OHWM UPSTREAM
 ELEVATION = 121.98

OHWM DOWNSTREAM
 ELEVATION = 15.79

0+00 1+00 2+00 2+44



APPENDIX H – LIGHTWEIGHT FILL PRODUCT INFORMATION

GEOTECH

Expanded Shale, Clay and Slate (ESCS) Lightweight Aggregate Soil Mechanics

Properties and Applications

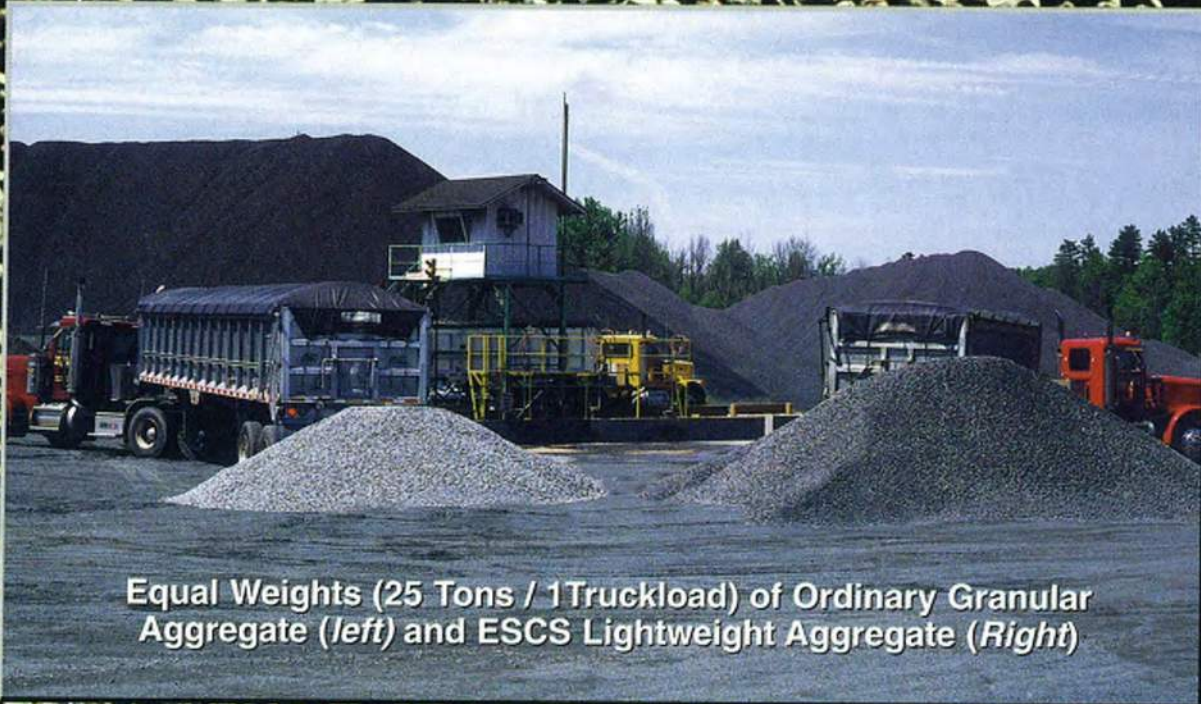

Equal Weights (25 Tons / 1 Truckload) of Ordinary Granular Aggregate (Left) and ESCS Lightweight Aggregate (Right)

NORTHEAST
ESCS
CORPORATION

1133 Kings Highway
Saugerties, New York 12477

www.nesolite.com

Tel: (845) 246-2646
Fax: (845) 246-3356

This Rock Works Wonders.



Expanded Shale, Clay and Slate (ESCS) compacted geotechnical fills are approximately half the weight of ordinary aggregate fills. This advantage, coupled with the high angle of internal friction of ESCS, can also reduce lateral forces by more than one-half. ESCS has been effectively used to solve numerous geotechnical engineering problems and to convert unstable soil into usable land. ESCS is a reliable, economical geotechnical solution.

ABSTRACT of the following paper: Structural grade lightweight aggregates (LWA) have been extensively used throughout North America for more than [80] years in cast-in-place structural lightweight concretes for high-rise buildings and bridges, and are now being widely used for geotechnical applications. Structural grade LWA, when used in backfills and over soft soils, provides geotechnical physical properties that include reduced density, high stability, high permeability, and high thermal resistance. These improved physical properties are found in aggregates with a reduced specific gravity and a predictable stability resulting from a consistently high angle of internal friction. The open texture available from a closely controlled manufactured aggregate gradation ensure high permeability. High thermal resistance results from porosity developed during the production process. In this publication, the physical properties of structural grade LWA and geotechnical engineering properties of LWA backfills are illustrated. Additionally, references to extensive testing programs that developed data on shear strength, compressibility, durability, and in-place density are given. Representative case studies are reported from [several hundred] projects that illustrate completed applications of structural grade LWA fills over soft soils and behind retaining walls and bridge abutments.

Lightweight Aggregate Soil Mechanics: Properties and Applications

T.A. Holm and A.J. Valsangkar

For more than [80] years, shales, clays, and slates have been expanded in rotary kilns to produce structural grade LWA for use in concrete and masonry units. Millions of tons of structural grade LWA produced annually are used in structural concrete applications. Its availability is currently widespread throughout most of the industrially developed world. Consideration of structural grade LWA as a remedy to geotechnical problems stems primarily from the improved physical properties of reduced dead weight, high internal stability, high permeability, and high thermal resistance. These significant advantages arise from the reduction in particle specific gravity, stability that results from the inherent high angle of internal friction, the controlled open-textured gradation available from a manufactured aggregate which assures high permeability, and the high thermal resistance developed because of the high particle porosity.

PHYSICAL PROPERTIES OF STRUCTURAL LIGHTWEIGHT AGGREGATES

Particle Shape and Gradation

As with naturally occurring granular materials, manufactured LWA's have particle shapes that vary from round to angular with a characteristically high interstitial void content that results from a narrow range of particle sizes. Applications of LWA to geotechnical situations require recognition of two primary attributes: (a) the high interstitial void content typical of closely controlled manufactured granular coarse aggregate that closely resembles a clean, crushed stone, and (b) the high volume of pores enclosed within the cellular particle.

Structural grade LWA gradations commonly used in high-rise concrete buildings and long-span concrete bridge decks conform to the requirements of ASTM C330. The narrow

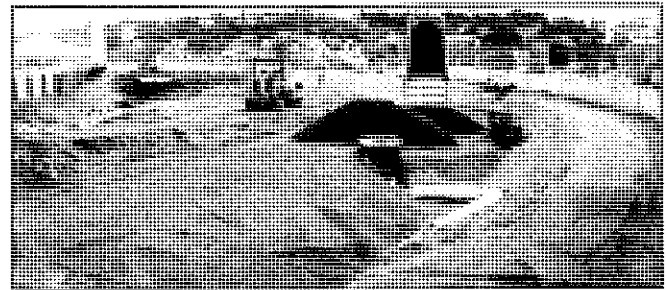

Retaining wall backfill, Providence, Rhode Island

range of particle sizes ensures a high interstitial void content that approaches 50% in the loose state. North American rotary kiln plants producing expanded shales, clays, and slates currently supply coarse [and fine] aggregates to ready-mix and precast concrete manufacturers with 20 to 5 mm (3/4 - #4), 13 to 5 mm (1/2 - #4), or 10 to 2 mm (3/8 - #8) gradations [and various fine aggregate gradings]. With [coarse] gradations there is a minimum percentage of fines smaller than 2 mm (#8 mesh) and insignificant amounts passing the 100 mesh screen.

Particle Porosity and Bulk Density

When suitable shales, clays, and slates are heated in rotary kilns to temperatures in excess of 1100° C (2012°F), a cellular structure is formed of essentially noninterconnected spherical pores surrounded by a strong, durable ceramic matrix that has characteristics similar to those of vitrified clay brick. Oven-dry specific gravities of LWA vary but commonly range from 1.25 to 1.40. Combination of this low specific gravity with high interparticle void content results in LWA bulk dry densities commonly in the range of 720 kg/m³ (45 pcf). Compaction of expanded aggregates in a manner similar to that used with crushed stone provides a highly stable interlocking network that will develop in-place moist densities of less than [960 kg/m³ (60 pcf)].

Differences in porosity and bulk density between LWA's

and ordinary soils may be illustrated by a series of schematic depictions. For comparative purposes, Figure 1 shows the interparticle voids in ordinary coarse aggregate. Although normal weight aggregates commonly have porosities of 1-2%, the schematic assumes ordinary aggregates to be 100% solid. For illustrative purposes, the bulk volume is shown to be broken into one entirely solid part with the remaining fraction being interparticle voids.

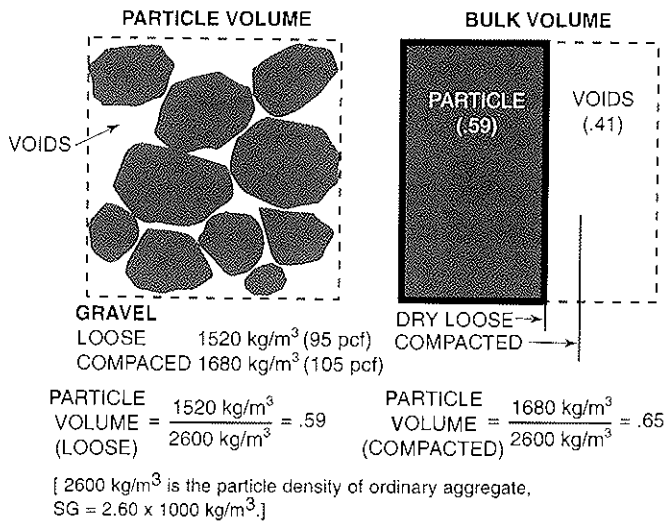

FIGURE 1 Voids in ordinary coarse aggregates

Figure 2 shows the cellular pore structure of a typical LWA. ASTM procedures prescribe measuring the “saturated” (*mis-named in the case of LWA’s; partially saturated after a 1-day soak is more accurate*) specific gravity in a pycnometer and then determining the moisture content on the sample that had been immersed in water for 24 hours. After a 1-day immersion in water, the rate of moisture absorption into the lightweight aggregate will be so low that the partially saturated specific gravity will be essentially unchanged during the time necessary to take weight measurements in the pycnometer. When the moisture content is known, the oven-dry specific gravity may be directly computed. This representative coarse LWA with a measured dry loose bulk unit weight of 714 kg/m³ (44.6 pcf) and computed oven-dry specific gravity of 1.38 results in the aggregate particle occupying 52% of the total bulk volume, with the remaining 48% composed of interparticle voids.

The specific gravity of the pore-free ceramic solid fraction of a lightweight aggregate may be determined by standard procedures after porous particles have been thoroughly pulverized in a jaw mill. Pore-free ceramic solids specific gravities measured on several pulverized LWA samples developed a mean value of 2.55. The representative LWA with a dry specific gravity of 1.38 will develop a 54% fraction of enclosed aggregate particle ceramic solids and a remaining 46% pore volume (Figure 2).

This leads to the illustration of the overall porosity in a bulk loose LWA sample as shown in Figure 3. Interparticle voids of the overall bulk sample are shown within the enclosed dotted area, and the solid pore-free ceramic and the internal pores are shown within the solid particle lines. For this representative LWA, the dry loose bulk volume is shown to be composed of 48% voids, 28% solids, and 24% pores.

$$\gamma_D \text{ (Dry Specific Gravity)} = \frac{\gamma_M \text{ (Partially Saturated Surface Dry Specific Gravity)}}{(1 - M) \text{ (1-Day Soak Moisture Content by Weight)}}$$

$$\gamma_D = \frac{1.50}{(1 + .085)} = 1.38$$

Fraction of bulk aggregate sample occupied by lightweight aggregate particles = $\frac{714 \text{ kg/m}^3}{1380 \text{ kg/m}^3} = .52$
 Fraction of bulk aggregate sample occupied by interparticle voids = $1.00 - .52 = .48$

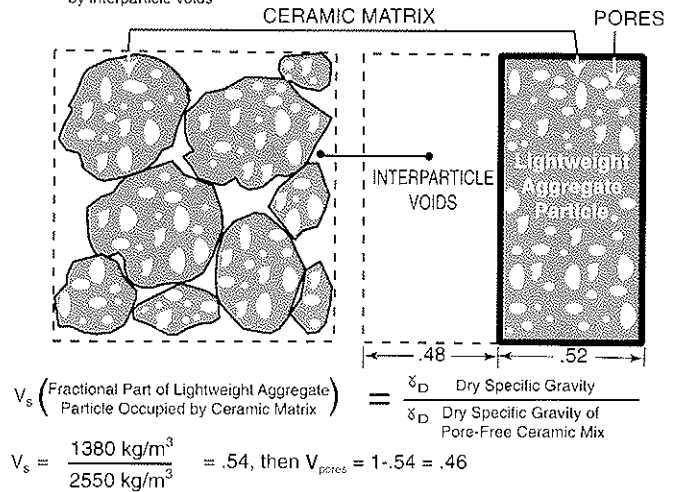
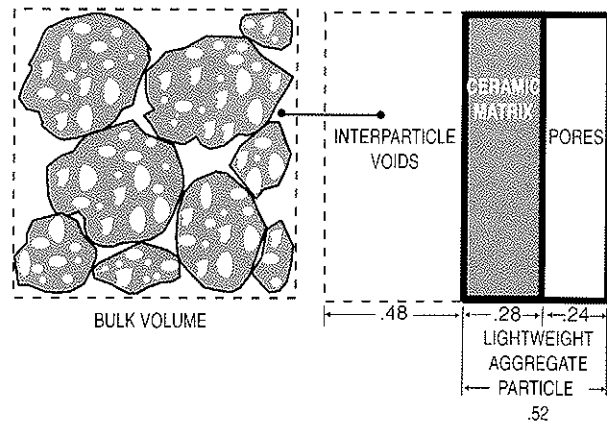

FIGURE 2 Interparticle voids and within-particle pores of lightweight aggregate (LWA)

VOLUMETRIC FRACTIONS IN DRY LOOSE LIGHTWEIGHT AGGREGATE SAMPLE

VOIDS = .48
 CERAMIC SOLIDS FRACTION = $.52 \times .54 = .28$
 LIGHTWEIGHT AGGREGATE PORES = $.52 \times .46 = .24$



LOOSE AGGREGATE CONDITION	INTERPARTICLE VOIDS	CERAMIC MATRIX	PORES	DENSITY kg/m ³
DRY	-	714	-	714 (44.6 pcf)
PARTIALLY SATURATED ONE-DAY DRY SOAK	-	714	61	775 (48.4 pcf)
VACUUM SATURATION	-	714	240	954 (59.6 pcf)
LONG TIME SATURATION [Submerged]	480	714	240	1434 - 1000 = 434 (27.1 pcf)

*Buoyant Unit Weight

FIGURE 3 Voids, pores, and ceramic matrix fraction in a lightweight aggregate (LWA) sample

Absorption Characteristics

LWA's stored in exposed stockpiles in a manner similar to crushed stone will have some internal pores partially filled and may also carry an adsorbed moisture film on the surface of the particles. The moisture content that is defined in ASTM procedures as "absorption" based on a 24-hour immersion and routinely associated in concrete technology with "saturated" surface-dry specific gravity is, in fact, a condition in which considerably less than 50% of the particle pore volume is filled.

The issue is further clarified by a schematic volumetric depiction (see Figure 4) of the degree of pore volume saturation of a LWA particle that shows that the sample had a measured damp loose bulk unit weight of 775 kg/m³ (48.4 pcf) with an 8.5% absorbed moisture and would, in fact, represent

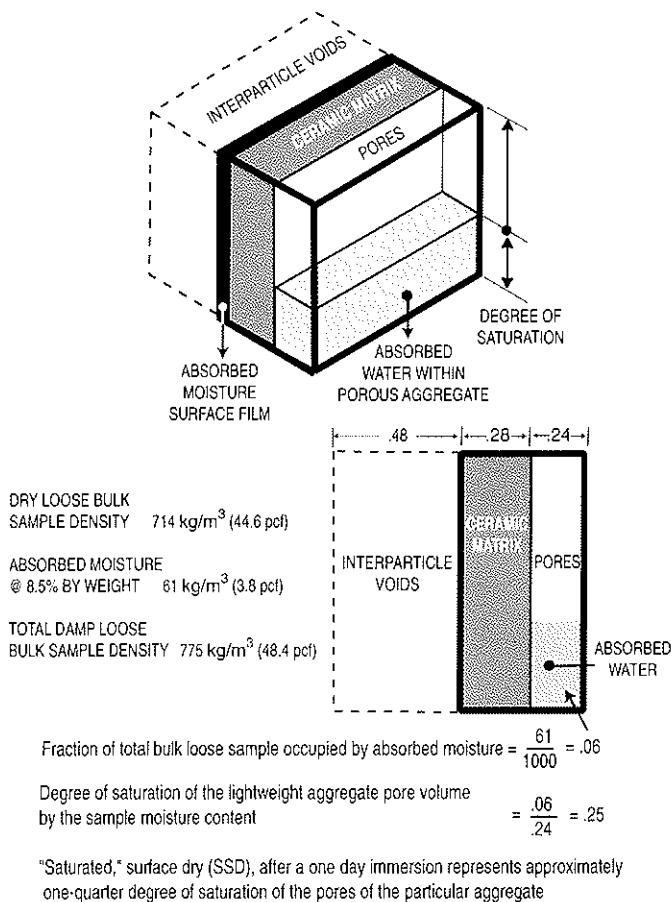

FIGURE 4 Degree of saturation of partially saturated lightweight aggregate (LWA)

a condition in which approximately 25% of the pore volume is water filled.

Structural grade LWA exposed to moisture in production plants and stored in open stockpiles will contain an equilibrium moisture content. LWA's that are continuously submerged will, however, continue to absorb water over time. In one investigation, the effective specific gravity of a submerged LWA sample was measured throughout a one-year period to demonstrate long-term weight gain. Long-term

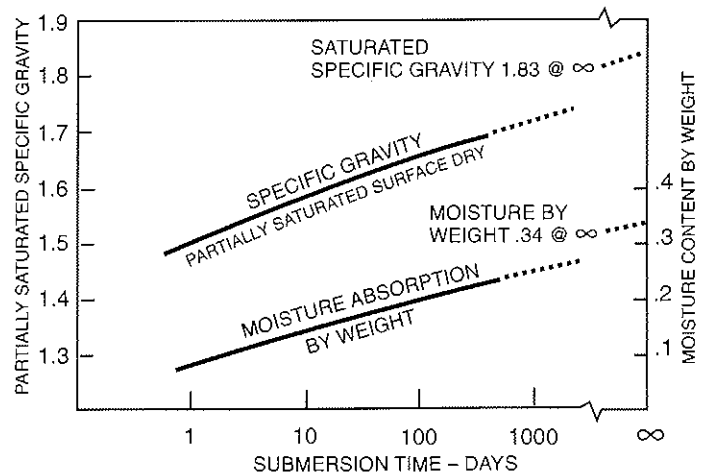

FIGURE 5 Moisture absorption (by weight) and partially saturated, surface dry specific gravity of lightweight aggregate (LWA) versus time of submersion

absorption characteristics are shown in Figure 5 for a LWA sample with a measured 1-day immersion moisture content of 8.5% associated with a partially saturated surface-dry specific gravity of 1.5. When moisture absorption-versus-time relationships are extrapolated or theoretical calculations used to estimate the total filling of all the LWA pores, it can be shown that for this particular LWA the absorbed moisture content at infinity will approach 34% by weight with a totally saturated specific gravity of 1.83. Complete filling of all pores in a structural grade LWA is unlikely because the non-interconnected pores are enveloped by a very dense ceramic matrix. However, these calculations do reveal a conservative upper limit for submerged design considerations.

Durability Characteristics

The durability of LWA's used in structural concrete applications is well known. More than 400 major U.S. bridges built using structural lightweight concrete (LWC) have demonstrated low maintenance and limited deterioration. Long-term durability characteristics of LWA's were demonstrated in 1991 by reclaiming and testing samples of the LWA fill supplied in 1968 to a Hudson River site. Magnesium soundness tests conducted on the reclaimed aggregate sample exposed to long-term weathering resulted in soundness loss values comparable to those measured and reported in routine quality control testing procedures 23 years earlier, indicating little long-term deterioration due to continuous submersion and freeze-thaw cycling at the waterline.

Although ASTM standard specifications C330 and C331 for lightweight aggregate make no mention of corrosive chemicals limitations, foreign specifications strictly limit SO₃ equivalents to 0.5% (*Japanese Industrial Standard J5002*) or 1.0% (*German Standard DIN 4226*). The American Concrete Institute Building Code (ACI 318) mandates chloride limitations in the overall concrete mass because of concern for reinforcing bar corrosion, but no limits are specified for individual constituents. Numerous geotechnical projects specifications calling for lightweight aggregates have limited water-soluble chloride content in the aggregate to be less than 100 ppm when measured by AASHTO T291.

GEOTECHNICAL PROPERTIES OF LIGHTWEIGHT FILL

In-Place Compacted Moist Density

Results of compacted LWA density tests conducted in accordance with laboratory procedures (Proctor tests) should be interpreted differently from those for natural soils. Two fundamental aspects of lightweight aggregate soil fill will modify the usual interpretation soils engineers place on Proctor test data. The first is that the absorption of LWA is greater than natural soils. Part of the water added during tests will be absorbed within the aggregate particle and will not affect interparticle physics (bulking, lubrication of the surfaces, etc.). Second, unlike cohesive natural soils, structural grade LWA contains limited fines, limiting the increase in density due to packing of the fines between large particles. The objective in compacting structural grade LWA fill is not to aim for maximum in-place density, but to strive for an optimum density that provides high stability without unduly increasing compacted density. Optimum field density is commonly achieved by two to four passes of rubber tire equipment. Excessive particle degradation developed by steel-tracked rolling equipment should be avoided. Field density may be approximated in the laboratory by conducting a one-point ASTM D698, AASHTO T99 Proctor test [using a 0.5 ft.³ bucket] on a representative LWA sample that contains a moisture content typical of the field delivery. Many projects have been successfully supplied where specifications called for an in-place, compacted, moist density not to exceed 960 kg/m³ (60 pcf).

Shear Strength

Structural grade LWA's provide an essentially cohesionless, granular fill that develops stability from inter-particle friction. Extensive testing on large 250 x 600 mm (10 x 24 in. high) specimens has confirmed angles of internal friction of more than 40 degrees (1). Triaxial compression tests completed on LWA from six production plants, which included variations in gradations, moisture content, and compaction levels, revealed consistently high angles of internal friction. With a commonly specified in-place moist compacted unit weight less than 960 kg/m³ (60 pcf), it may be seen from a simplistic analysis that lateral pressures, overturning moments, and gravitational forces approach one-half of those generally associated with ordinary soils.

A summary of the extensive direct shear testing program conducted by Valsangkar and Holm (2), presented in the following table, confirm the high angle of internal friction measured on large-scale triaxial compression testing procedures as reported earlier by Stoll and Holm (1).

<i>Material</i>	<i>Angle of Internal Friction (degree)</i>	
	<i>Loose</i>	<i>Compacted</i>
Minto [LWA]	40.5	48.0
Solite [LWA]	40.0	45.5
Limestone	37.0	N/A
Solite (1) [LWA]	39.5	44.5

Compressibility

Large-scale compressibility tests completed on lightweight aggregate fills demonstrated that the curvature and slope of the LWA fill stress-strain curves in confined compression were similar to those developed for companion limestone samples (2). Cyclic plate-bearing tests on LWA fills indicated vertical subgrade reaction responses that were essentially similar for the lightweight and normal weight aggregate samples tested (3).

Attempts by concrete technologists to estimate aggregate strength characteristics by subjecting unbound LWA samples to piston ram pressures in a confined steel cylinder have provided inconsistent and essentially unusable data for determination of the strength making characteristics of concretes that incorporate structural grade LWA. By ASTM C330 specifications, all structural grade LWA's are required to develop concrete strengths above 17.2 MPa (2500 psi). Most structural grade LWA concrete will develop 34.4 MPa (5000 psi), and a small number can be used in concretes that develop compressive strengths greater than 69 MPa (10,000 psi).

Thermal Resistance

For more than [8] decades, design professionals have used lightweight concrete masonry and lightweight structural concrete on building facades to reduce energy losses through exterior walls. It is well demonstrated that the thermal resistance of LWC is considerably less than that of ordinary concrete, and this relationship extends to aggregates in the loose state (4).

Permeability

Attempts to measure permeability characteristics of unbound LWA have not been informative because of the inability to measure the essentially unrestricted high flow rate of water moving through open-graded structure. This characteristic has also been observed in the field, where large volumes of water have been shown to flow through LWA drainage systems. Exfiltration applications of LWA have demonstrated a proven capacity to effectively handle high volumes of storm water runoff. Subterranean exfiltration systems have provided competitive alternatives to infiltration ponds by not using valuable property areas as well as eliminating the long-term maintenance problems associated with open storage of water.

Interaction Between Lightweight Aggregate Fills and Geotextiles

Valsangkar and Holm (5) reported results of testing programs on the interaction between geotextiles and LWA fills that included the variables of differing aggregate types and densities, thickness of aggregate layer, and geotextile types. The results indicated that the overall roadbed stiffness is unaffected when LWA is used instead of normal weight aggregate for small deflections and initial load applications. These tests were followed by a large-scale test (2), which reported that the comparison of the friction angles between the LWA or the normal weight aggregate and the geotextiles indicate that interface friction characteristics are, in general, better for LWA than normal weight aggregates.

APPLICATIONS

During the past decade several hundred diverse geotechnical applications have been successfully supplied with structural grade LWA. The applications primarily fit into the following major categories:

- Backfill behind waterfront structures, retaining walls, and bridge abutments;
- Load compensation and buried pipe applications on soft soils;
- Improved slope stability situations; and
- High thermal resistance applications.

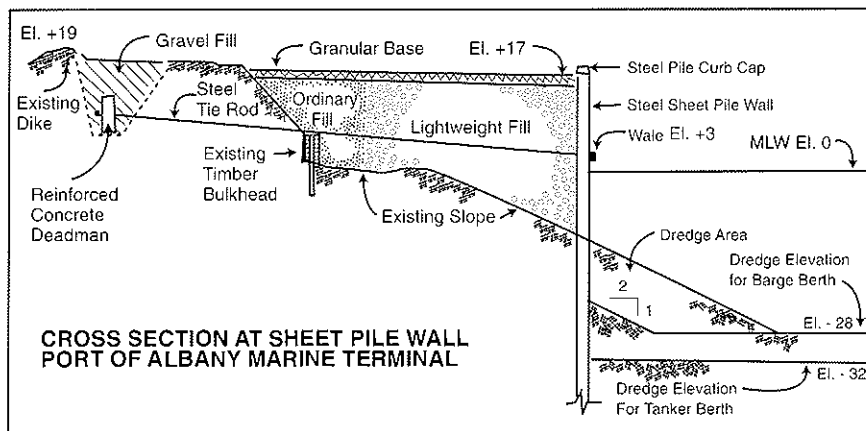

FIGURE 6 Rehabilitation of Port of Albany, New York [1981]

Backfill Behind Waterfront Structures, Retaining Walls and Bridge Abutments

A classic example of how unusable river front was reclaimed and large industrial site extended by the use of sheet piles and lightweight fill is demonstrated in Figure 6 (6). LWA fill specifications for this project required rotary kiln expanded shale to have a controlled coarse aggregate gradation of 20 to 5 mm (3/4 - #4) and laboratory test certi-

fication of an angle of internal friction greater than 40 degrees. No constructability problems were experienced by the contractor while transporting, placing, and compacting the LWA soil fill. Peak shipment were more than 1,000 tons per day without any logistical difficulties. The material was trucked to the point of deposit at the job site and distributed by front-end loaders. This project used approximately 20,000 m³ (27,000 yd³) of compacted LWA and resulted in overall savings by reducing sizes of sheet piling and lowering costs associated with the anchor system.

On the Charter Oak Bridge project, Hartford, Connecticut, constructed in 1989 to 1990, LWA fill was placed in the east abutment area to avoid placing a berm that would have been necessary to stabilize an earth fill embankment. According to the designer, construction of a berm would have required relocating a tributary river. LWA fill was also used in other areas to avoid increasing stresses and settlements in an old brick sewer (7). When all applications were totaled, this project incorporated more than 100,000 tons of structural grade LWA.

Load Compensation and Buried Pipe Applications on Soft Soils

In numerous locations throughout North America, design of pavements resting on soft soils has been facilitated by a "load compensation" replacement of heavy soils with a free-draining structural grade LWA with low density and high stability. Replacing existing heavy soil with LWA permits raising elevations to necessary levels without providing any further surcharge loads to the lower-level soft soils. Rehabilitation of Colonial Parkway near Williamsburg, Virginia, built alongside the James and York rivers, provides a representative example of the procedure. Soft marsh soil sections of this roadway had a low load-bearing capacity, and had experienced continuous settlement. The concrete roadway slabs were removed along with the soil beneath to a depth of more than 3 ft. The normal weight soil was then replaced with structural-grade LWA with a compacted moist density of less than 960 kg/m³ (60 pcf), providing effective distribution of load to the soft soil layer, load compensation, and side

slope stability. Reconstruction was completed in two stages by first completely rehabilitating in one direction, followed by excavation of the opposing lane with delivery, compaction, and slab construction routinely repeated.

Construction of pipelines in soft soil areas has frequently been facilitated by equalizing the new construction weight (pipe plus LWA backfill) to the weight of the excavated natural soil. Supporting substrates do not "see" any increased loading and settlement forces are minimized.

Improved Slope Stability

Improvement of slope stability has been facilitated by LWA in a number of projects prone to sliding. Waterside railroad tracks paralleling the Hudson River in the vicinity of West Point, New York, had on several occasions suffered serious misalignment due to major subsurface sliding because of soft clay seams close to grade level. After riverbank soil was excavated by a barge-mounted derrick, LWA was substituted and the railroad track bed reconstructed. Reduction of the gravitational force driving the slope failure combined with the predictable LWA fill frictional stability provided the remedy for this problem. Troublesome subsoil conditions in other area, including the harbors in Norfolk, VA, and Charleston, SC, have also been similarly remedied.

High Thermal Resistance Applications

Structural LWA has been effectively used to surround high-temperature pipelines to lower heat loss. Long-term, high-temperature stability characteristics can be maintained by aggregates that have already been exposed to temperatures of 1100° C (2012° F) during the production process. Other applications have included placing LWA beneath heated oil processing plants to reduce heat flow to the supporting soils.

ECONOMICS

An economic solution provided by a design that calls for an expensive aggregate requires brief elaboration. In many geographical areas, structural-grade LWA's are sold to ready-mix, precast, and concrete masonry producers on the basis of a price per ton, FOB the plant. On the other hand, the contractor responsible for the construction of the project bases costs on the compacted material necessary to fill a prescribed volume. Because of the significantly lower bulk density, a fixed weight of this material will obviously provide a greater volume. To illustrate that point, one may presume that if a LWA is available at \$X/ton, FOB the production plant, and trucking costs to the project location call for additional \$Y/ton, the delivered job site cost will be \$(X+Y)/ton. As mentioned previously, many projects have been supplied with structural LWA aggregates delivered with a moist, loose density of about [770 kg/m³ (48 pcf)] and compacted to a moist, in-place density [less than the typically specified 960 kg/m³ (60 pcf)]. This would result in an in-place, compacted moist density material cost (not including compaction cost) of

$$\{ \$ (X + Y) \times 60 \times 27 \} / 2,000$$

for the compacted, moist lightweight aggregate.

[Additional Economic Benefits - April 2001]

- Approximately twice as much volume of LWA can be transported per load as compared to normal weight.
- In restricted or commercial areas, cutting the number of trucks by half is environmentally significant.
- Loader or crane bucket volume can be increased to allow faster placement and longer reaches.
- In tight spaces where hand placement and compaction is required, LWA is much easier to handle and offers considerable labor savings.

CONCLUSIONS

Structural grade LWA fills possessing reduced density, high internal stability, and high permeability have been extensively specified and used to replace gravel, crushed stone, and natural soils for geotechnical applications at soft soil sites and in backfills where the assured reduction in lateral and gravitational forces has provided economical solutions.

REFERENCES

1. Stoll, R.D., and T.A. Holm; Expanded Shale Lightweight Fill: Geotechnical Properties, *Journal of Geotechnical Engineering*, ASCE, Vol. 111, No. 8, Aug. 1985
2. Valsangkar, A.J., and T.A. Holm; Geotechnical Properties of Expanded Shale Lightweight Aggregate, *Geotechnical Testing Journal*, ASTM, Vol. 13, No.1, March 1990, pp 10-15
3. Valsangkar, A.J., and T.A. Holm; *Cyclic Plate Load Tests on Lightweight Aggregate Beds*, Presented at the 72nd Annual Meeting of the Transportation Research Board, Washington, D.C., Jan. 1993
4. Valore, R.C.; *The Thermophysical Properties of Masonry and Its Constituents*, International Masonry Institute, Washington D.C., 1988
5. Valsangkar, A.J., and T.A. Holm; Model Tests on Peat-Geotextile-Lightweight Aggregate System, *Geotextiles and Geomembranes*, Elsevier Science Publishers, Ltd., England, 1987
6. Childs, K., D.L. Porter, and T.A. Holm; Lightweight Fill Helps Albany Port Expand, *Civil Engineering*, ASCE, April 1983
7. Dugan, J.P., Jr.; *Engineering News Record*, Haley and Aldrich, Inc., ENR Letters, New York, Aug. 23, 1990

Reprinted with permission of the Transportation Research Board, National Research Council, Washington, D.C., *Transportation Research Record 1422; Soils Geology and Foundations; Lightweight Artificial and Waste Materials for Embankments Over Soft Soils*, T.A. Holm and A.J. Valsangkar, January 1993
Reprinted March 2001

The principal author, Thomas Holm, has supervised this reprinting by the Expanded Shale, Clay and Slate Institute. Under his direction, Figures 1, 2, and 3 have been modified for clarity. Other updated information is indicated by brackets [].

**ESCS Structural Lightweight Aggregate Is
Approximately Half the Weight of Ordinary Aggregates**



SOIL

GRAVEL

ESCS

STONE

SAND

Equal Weights of Aggregates
(Note: ESCS is approximately twice the volume)



Expanded Shale, Clay and Slate Institute
2225 Murray-Holladay Road • Suite 102
Salt Lake City, Utah 84117 • 801-272-7070 • Fax 801-272-3377
www.escsi.org

Ultra-lightweight Foamed Glass Aggregate

Design and Construction Considerations

1.0 INTRODUCTION

This document presents guidelines for the use of ultra-lightweight foamed glass aggregate (UL-FGA). UL-FGA is a lightweight material that can be used for many applications including embankment fill, retaining wall or MSE backfill, utility backfill, and insulation for buildings or roadways. This document includes a discussion of the typical properties of UL-FGA, applications where UL-FGA may be beneficial, and UL-FGA design and construction requirements and considerations.

Foamed Glass Aggregates are extremely lightweight, manufactured aggregates produced from 100% recycled glass. The manufacturing process takes recycled glass powder and mixes it with a foaming agent, where it is then sent through a kiln and softened. During this process, bubbles are created within the softened glass due to the foaming agent creating foamed glass aggregates.

1.1 Typical Uses of Foamed Glass Aggregate

UL-FGA is intended to be used as a lightweight or insulating fill for embankments, backfill behind retaining structures, MSE wall backfill over soft soils to mitigate settlement, or place as fill over existing buried structures or utilities where the weight of conventional backfill can result in excessive settlement and/or structural damage. UL-FGA is also used as an insulation material in many applications due to its low thermal conductivity.

1.2 Foamed Glass Aggregate Properties

The physical properties of UL-FGA G15 in lightweight fill applications are as follows:

1. Unit Weight: The unit weight a designer may consider will depend on the maximum, typical, minimum value, bulk vs. compacted state (and specified percent compaction), and moisture content. The maximum dry bulk unit weight of UL-FGA G15 is 15 pcf. Moist bulk unit weights can vary but are generally between 15 and 18.75 pcf. A moist, in-place unit weight of 23.5 pcf can be used for design considering 20% compaction for each lift.
2. Buoyant Unit Weight: The buoyant unit weight of UL-FGA G15 has been determined through testing to be -15 pcf. Therefore, applying a factor of safety of 1.5, the design buoyant unit weight of UL-FGA is -22 pcf.

3. Shear Strength: Shear strength parameters will be affected by the proposed normal stress. The apparent friction angle was determined per ASTM D 3080 modified. The friction angle data is shown in Table 1.2-1. Most UL-FGA applications will fall into the <1200 psf normal stress range, but every application should be evaluated by the designer.

Table 1.2-1 – Fiction Angles for Varying Normal Stresses

Normal Stress, maximum	Apparent Peak Friction Angle, Degrees
1200 psf	54-55
3000 psf	41-45

4. Permeability: The grain size distribution for UL-FGA G15 (pre- and post-compaction) and the particle shape make UL-FGA comparable to gravel and crushed aggregate. This means that the permeability is likely ≥ 0.03 ft/s (1 cm/s).
5. Resilient Modulus, M_r : The resilient modulus of UL-FGA G15 at a representative compacted unit weight has been tested per AASHTO T 307-99. The average M_r results for samples with dry unit weights between 16.4 and 17.2 pcf vary between 14,800 and 47,400 psi under a range of confining and cyclic deviator stresses. The resilient modulus for a layer of UL-FGA G15 can be utilized for pavement subgrade conditions in a linear-elastic analysis of a pavement cross section.
6. Elastic Modulus, E : The elastic modulus for UL-FGA may vary based on the overlying, adjacent, and underlying layers. Typically, the elastic modulus is between 7,290 to 10,070 psi determined through 12" plate load test or lightweight deflectometer (LWD) testing on compacted UL-FGA.
7. Creep: Creep testing on UL-FGA up to a stress of 5,200 psf (2.6 tsf) extrapolates that creep deformation (i.e., the deformation that will occur after one day) at 50 years to range between 0.6% and 1.8%. When designing structures, the thickness of UL-FGA, the bearing pressure of the structure on the UL-FGA layer, and the allowable settlement should be considered. Scandinavian UL-FGA manufacturers recommend that bearing pressures on the UL-FGA layer be limited to 80-120 kPa (~1670-2500 psf) to limit creep strains to <0.1% from Day 1 to Year 50.

2.0 DESIGN REQUIREMENTS AND CONSIDERATIONS

Generally, geotechnical analyses are required to design UL-FGA for lightweight fill applications. These analyses include settlement and global slope stability. In some cases, additional analyses including bearing resistance and sliding must be performed. These analyses are discussed below along with other design requirements and considerations for the use of UL-FGA.

2.1 Settlement Analyses (Creep/Static Load Conditions)

UL-FGA may be used as an option to eliminate or reduce the estimated settlement from embankment construction to a tolerable level. A typical UL-FGA embankment section is shown in Figure 2.1-1. Usually, settlement analyses of underlying soil is performed to justify the need for the use of UL-FGA in place of more standard or other lightweight fill materials and to also determine the required limits of the UL-FGA within the embankment cross-section. Immediate, primary consolidation, and secondary consolidation settlement must be considered for underlying fine-grained soil layers. The settlement of underlying soils can be evaluated using the design unit weight for UL-FGA and other overlying layers. A differential settlement analysis of the underlying soil layers should be evaluated for the UL-FGA roadway section and adjacent sections. If differential settlement is a concern, the UL-FGA layer may be sloped in a transition section.

For structures, settlement analyses should also consider the elastic and creep settlement of the UL-FGA layer in addition to the settlement of the soil layers underlying the UL-FGA layer.

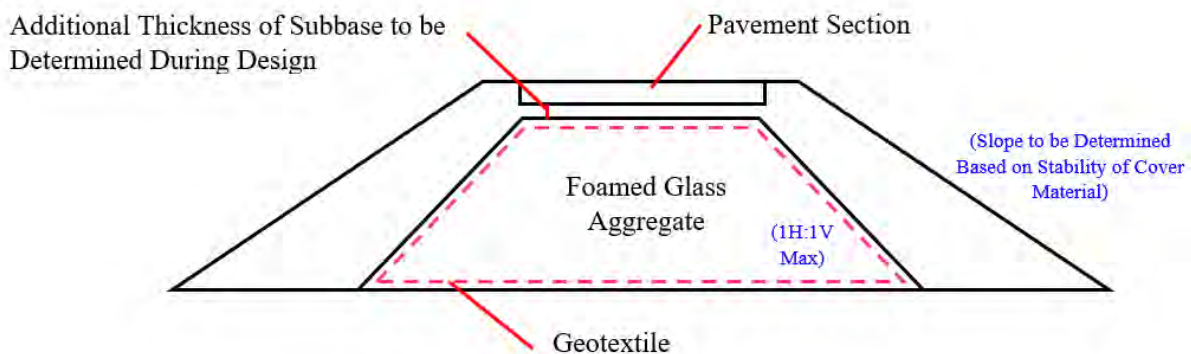

Figure 2.1-1 – Typical UL-FGA Embankment Section

2.2 Global Slope Stability Analyses

Global slope stability analyses may be performed similar to analyses performed for conventional embankments constructed with earth materials. Since the in-situ foundation material will often be saturated, cohesive soil, both undrained and drained shear strength parameters must be used in the analyses. In general, embankments or walls that are 50 feet and smaller will operate at normal stresses less than 1200 psf. For embankments greater than 50 feet or those with special loading conditions such as under structures, a more detailed analysis of stress conditions will be necessary. Based on the results of this analysis, the UL-FGA layer may be subdivided and assigned the appropriate friction angle based on the anticipated normal stress (Refer to Section 1.2).

2.3 Buoyancy

Closed cell foamed glass aggregate is buoyant and susceptible to uplift when submerged in water because of its low unit weight. Consequently, a buoyancy analysis must be performed if UL-FGA is used in the vicinity of a stream, river, etc. and is usually based on the anticipated high water level (e.g., the 100-year storm elevation). This analysis will confirm that the proposed cover material provides enough ballast force to prevent movement of the UL-FGA. Additionally, in the event the area is subject to flooding/ponding, the contractor should provide a staging plan or propose other measures to ensure that all placed UL-FGA is properly ballasted. Traffic loads and any other temporary or short-term loads should not be included when calculating the uplift resisting force. The design value to be used for the buoyant unit weight is provided in Section 1.2.

2.4 UL-FGA Dynamic/Live Load Conditions

The anticipated dynamic loads in flexible pavement systems should be properly considered in the pavement design where UL-FGA is an underlying layer. UL-FGA does not replace subbase in a flexible pavement system. The design resilient modulus for a layer of UL-FGA can be utilized for pavement subgrade conditions in a linear-elastic analysis of a pavement cross section.

During construction, vehicles and other construction equipment may have limited travel over the UL-FGA layer once a minimum of 6 inches of capping material is placed. If a haul road is to be located over the UL-FGA layer, an evaluation of the capping material thickness under the haul road should be completed.

2.5 Bearing Resistance

The bearing capacity/resistance analysis may be necessary (especially where treatment for settlement involves soft foundation materials). In general, the placement of signs, lights, and other structures with significant bearing pressures should be avoided within the UL-FGA layer. The typical detail for a lighting foundation is shown in Figure 2.5-1 and is supported on crushed stone or natural material. However, the concrete footing shown in Figure 2.5-1 should be moved so that the induced pressure distribution only acts in conventional backfill material or the dissimilar bearing materials shall be accounted for in the design. If structures are proposed on the UL-FGA layer, a proper settlement analysis using creep data should be completed.

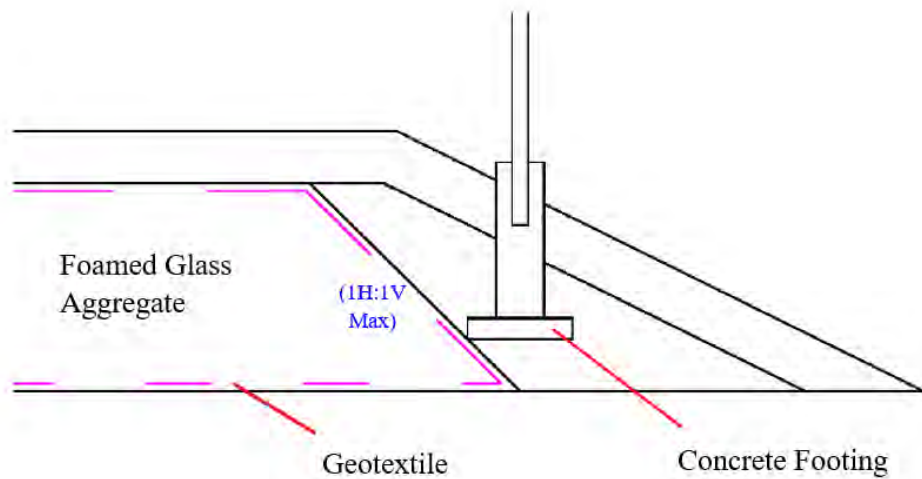

Figure 2.5-1 – Typical Detail of Lighting Foundation where UL-FGA is used.

Roadway embankments typically contain drainage pipes and inlet boxes, and often also have underground utilities, utility poles, light poles, signs, guide rail posts and other appurtenances. These can be incorporated into an UL-FGA embankment, but careful consideration should be given during design. When possible, locate these appurtenances outside the limits of the UL-FGA or in the embankment cover material above the UL-FGA.

2.6 Lateral Load/Earth Pressure Considerations

Lateral earth pressure from soil or aggregate backfill placed behind UL-FGA must be considered during design. For example, if UL-FGA is used to backfill behind an abutment

or retaining wall and embankment material is used to construct the remainder of the embankment cross-section, lateral earth pressure from the embankment material may be applied to the UL-FGA which in turn will transfer the lateral load to the wall or abutment. In order to avoid developing lateral earth pressure, the embankment material behind the UL-FGA must be placed at a slope that is independently stable, such as 2H:1V (i.e., sufficiently beyond the active earth pressure wedge such that no lateral loads can be transferred to the wall) or the lateral loads from the fill placed behind the UL-FGA must be accounted for in the design.

2.7 Cover Requirements:

There are numerous capping materials that may be used to cover the UL-FGA layer including embankment material subbase, topsoil, or rock.

Thickness: The minimum compacted lift thickness of capping material in non-live load situations should be six (6) inches. For live load conditions, see Section 2.4.

2.8 Mechanically Stabilized Earth (MSE) Structures

UL-FGA may be utilized as MSE backfill soil. Lift thicknesses may be influenced by the location of reinforcement within the UL-FGA. Compaction of UL-FGA adjacent to structures or panels should be completed with a plate compactor at lift thicknesses of 12 inches or less. Full-scale pullout testing (per ASTM D 6706/modified) will be required to be submitted to verify the properties used in the internal stability analysis.

2.9 Removal and Reuse of UL-FGA Material

UL-FGA may be removed and reused. UL-FGA will always be separated from other materials with a geotextile which will enable easy separation from other soils during excavation. If UL-FGA is reused in design, it is suggested that the design unit weight be increased by 25% to account for crushing of material during handling.

2.10 Pipe Backfill Envelope

If UL-FGA is proposed for use within a pipe backfill envelope, the design should demonstrate that the proposed pipe installation using UL-FGA in the pipe backfill envelope meets structural and service requirements.

3.0 CONSTRUCTION REQUIREMENTS AND CONSIDERATIONS

The construction requirements below must be accounted for during design of UL-FGA embankments.

3.1 Subgrade Preparation, Placement, and Drainage

In general, the subgrade soil should be prepared for UL-FGA placement. However, UL-FGA may be placed over poor subgrade soils. Removal of ponded water is required. Placement of a 6 oz./sy (minimum) or Class 2 nonwoven geotextile (per AASHTO M 288) is required above, below, and along the sides of the UL-FGA layer. UL-FGA should be placed in accordance with the contract drawings and specifications.

UL-FGA is a highly permeable layer (similarly to other open graded gravel soils) and will provide water storage (exhibit a "bathtub effect") if adjacent soil is less permeable and no other drainage is provided. Provide sufficient drainage for UL-FGA using grading or a pipe collector system.

3.2 Capping/Cover Requirements:

A minimum 6 inches of compacted capping material is required. See Section 2.7 for Cover types and installation requirements.

The capping material must be placed within 2 weeks after placement of the geotextile to help prevent degradation of the geotextile.

These design and construction considerations have been compiled based on standard applications and experience. For applications outside of the conditions mentioned, please contact the Aero Aggregates technical department.