

HIGH POINT ELEV = 14.03
HIGH POINT STA = 105+36.67
PVI STA = 105+50.00
PVI ELEV = 14.57
A.D. = -1.80%
K = 133.33
240' VC

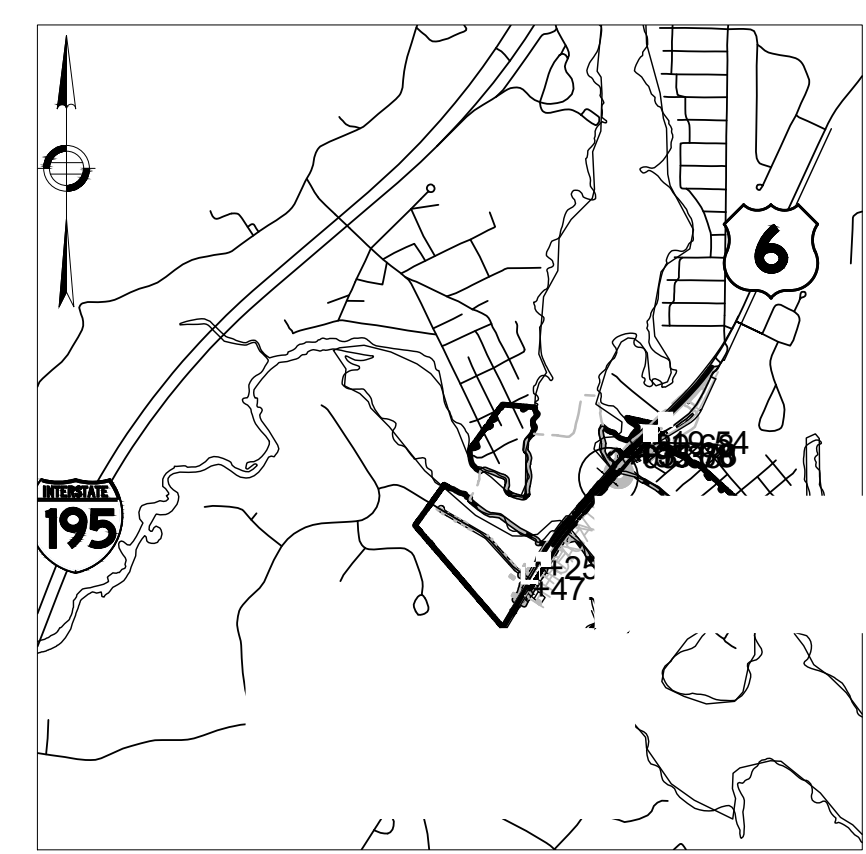
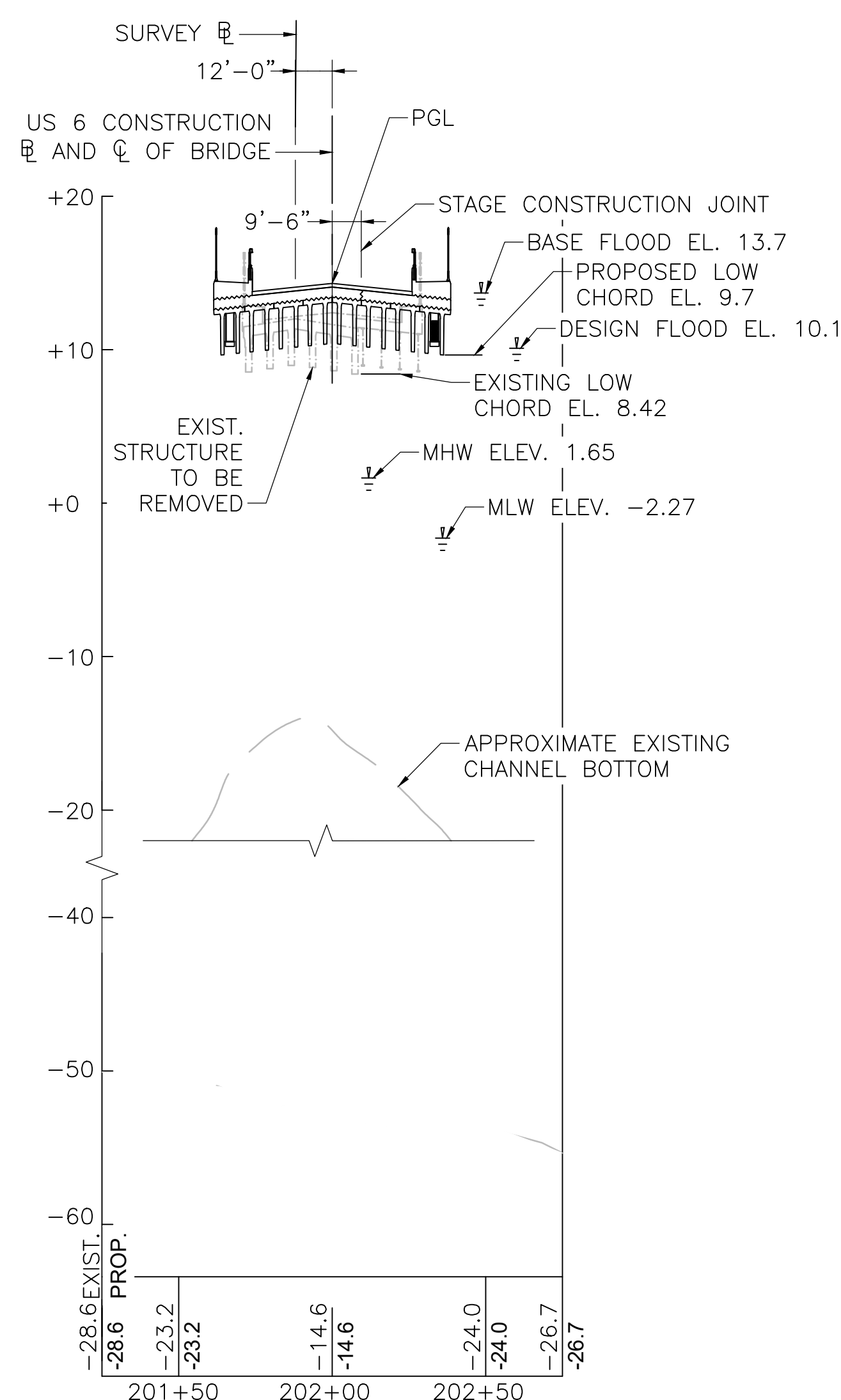
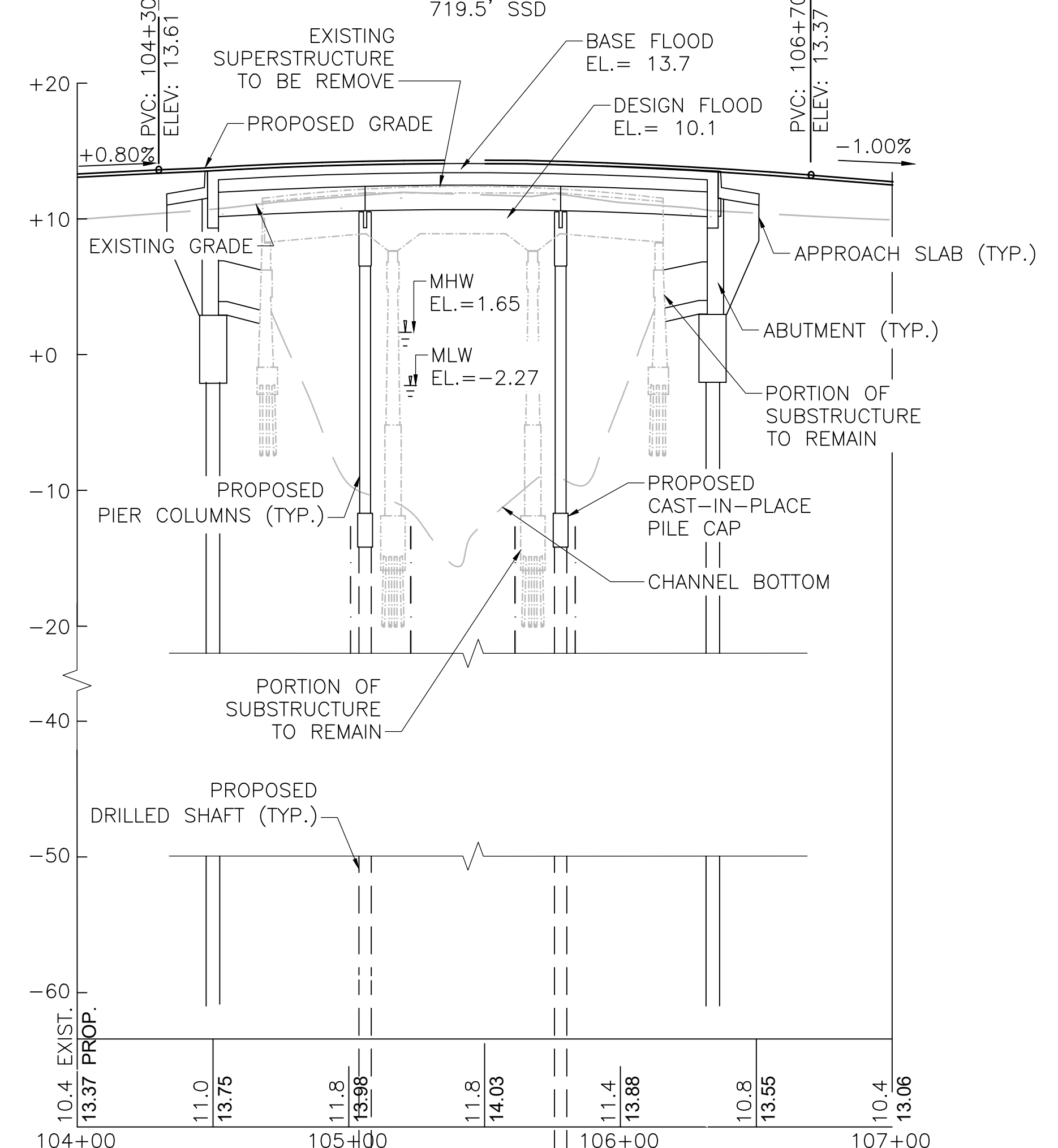

DESIGN:
IN ACCORDANCE WITH THE 2020 AMERICAN ASSOCIATION OF STATE HIGHWAY AND TRANSPORTATION OFFICIALS (AASHTO) LRFD BRIDGE DESIGN SPECIFICATIONS FOR HL-93 LOADING AND MASSDOT LRFD BRIDGE DESIGN MANUAL - LATEST EDITION.

- NOTES:**
- SEE GEOTECHNICAL DATA REPORT, DATED SEPTEMBER 2024. SEE RFP FOR FURTHER GEOTECHNICAL INFORMATION AND REQUIREMENTS.
 - SEE HYDRAULIC REPORT, DATED XXXXXX.
 - NORTH AMERICAN VERTICAL DATUM (NAVD) OF 1988 IS USED THROUGHOUT.
 - MATERIAL REQUIREMENTS SHALL BE IN ACCORDANCE WITH MASSDOT ENGINEERING DIRECTIVES AND RFP REQUIREMENTS.

TRAFFIC DATA		
	ROADWAY OVER	ROADWAY UNDER
DESIGN YEAR	2044	N/A
AVERAGE DAILY TRAFFIC - PRESENT	9,559	N/A
AVERAGE DAILY TRAFFIC - DESIGN YEAR	10,302	N/A
DESIGN HOURLY VOLUME	907	N/A
DIRECTIONAL DISTRIBUTION	DIST	N/A
TRUCK PERCENTAGE - AVERAGE DAY	2.3%	N/A
TRUCK PERCENTAGE - PEAK HOUR	2.45%	N/A
DESIGN SPEED	55 MPH	N/A
DIRECTIONAL DESIGN HOURLY VOLUME	439	N/A

SEISMIC DESIGN CRITERIA	
DESIGN RETURN PERIOD:	1000 YEARS
DESIGN SPECTRA	
As	0.138
SDs	0.290
SD1	0.112
SITE CLASS	E
SEISMIC DESIGN CATEGORY (SDC)	A

HYDRAULIC DESIGN DATA		
DRAINAGE AREA:	N/A	SQ. MILES
DESIGN FLOOD DISCHARGE:	N/A	C.F.S.
DESIGN FLOOD FREQUENCY:	25	YEARS
DESIGN FLOOD VELOCITY:	N/A	F.P.S.
DESIGN FLOOD ELEVATION:	10.1	FEET, NAVD

BASE (100-YEAR) FLOOD DATA		
BASE FLOOD DISCHARGE:	N/A	C.F.S.
BASE FLOOD ELEVATION:	13.7	FEET, NAVD

DESIGN AND CHECK SCOUR DATA		
DESIGN SCOUR FLOOD EVENT RETURN FREQUENCY:	50	YEARS
DESIGN FLOOD ABUTMENT SCOUR DEPTH:	29.57	FEET
DESIGN FLOOD PIER SCOUR DEPTH:	33.42	FEET
CHECK SCOUR FLOOD EVENT RETURN FREQUENCY:	100	YEARS
CHECK FLOOD ABUTMENT SCOUR DEPTH:	36.45	FEET
CHECK FLOOD PIER SCOUR DEPTH:	39.17	FEET

FLOOD OF RECORD		
DISCHARGE:	N/A	C.F.S.
FREQUENCY (IF KNOWN):	N/A	YEARS
MAXIMUM ELEVATION:	N/A	FEET, NAVD
DATE:	N/A	MONTH, YEAR
HISTORY OF ICE FLOES:	N/A	N.A.
EVIDENCE OF SCOUR AND EROSION:	N/A	N.A.

NOTE: VALUES IN THE HYDRAULIC TABLE ARE SUBJECT TO CHANGE. FINAL HYDRAULIC REPORT HAS NOT BEEN ISSUED AT TIME OF BTC PLANS. FINAL HYDRAULIC REPORT WILL BE PROVIDED IN ADDENDUM WHEN COMPLETE.

PROJECT INFORMATION			
PROJECT FILE NO.:	605311		
PROJECT DESCRIPTION:	PROPOSED BRIDGE		
BRIDGE DESIGN LOADING:	HL-93		
SURVEY:	ELECTRONIC SURVEY BY SURVEY AND MAPPING CONSULTANTS (SMC)		
ELEVATION REFERENCE:	NAVD OF 1988		
BENCH MARK:			
BENCHMARK	N	2730951.302	E 862244.338 8.513
BM	N	2731012.918	E 862341.519 9.915
BM	N	2729975.537	E 861297.506 15.758
BM	N	2730619.515	E 861833.717 17.320
POINT 1550	N	2729590.234	E 861126.664 17.719
BENCHMK	N	2730776.727	E 861969.623 11.500

PARSONS
100 HIGH STREET
BOSTON, MA 02110

massDOT
Massachusetts Department of Transportation
Highway Division

WAREHAM
US 6 (MARION ROAD)
OVER WEWEANTIC RIVER

MASSACHUSETTS DEPARTMENT OF TRANSPORTATION
HIGHWAY DIVISION

APPROVED BY _____ DATE _____

STRUCTURAL ELEMENTS: _____

TITLE: _____

HIGHWAY ELEMENTS: _____

TITLE: _____

605311_Sk01_BrW06016.DWG Plotted on 11-Sep-2024 7:34 PM 605311 Sketch Plan Submittal (SP3) March-2024

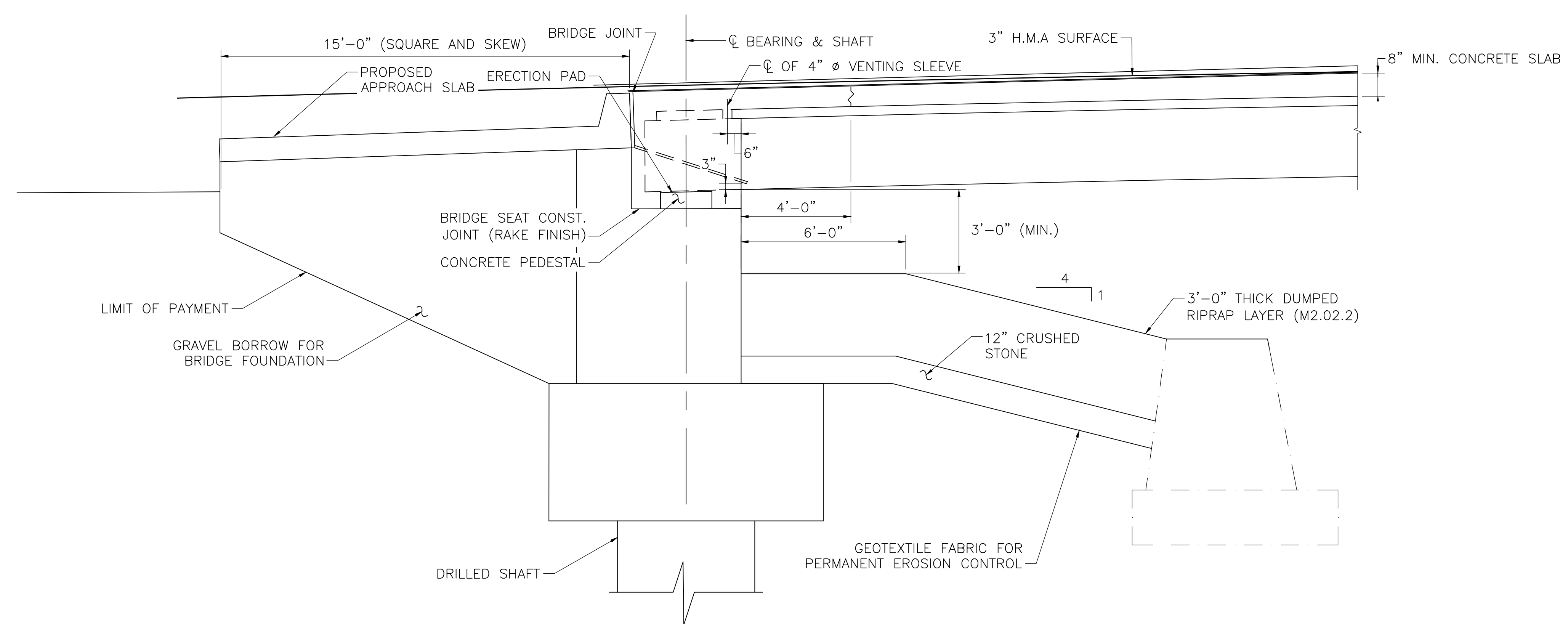
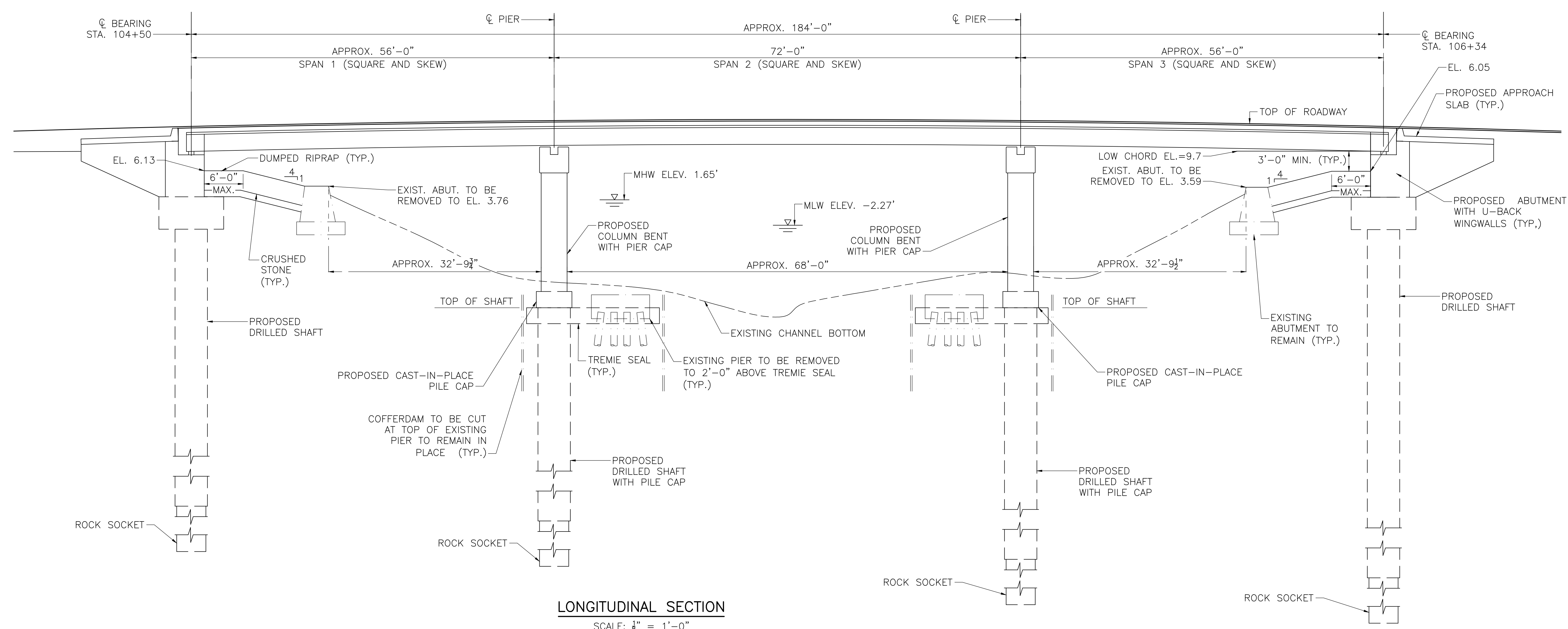

- NOTES:**
1. THE DESIGN FACTORED AXIAL COMPRESSIVE LOAD PER PILE IS TBD BY DB ENTITY.
 2. BASE TECHNICAL CONCEPT DIMENSIONS SHOWN ARE APPROXIMATE. DESIGN-BUILDER TO ADJUST AS REQUIRED BY FINAL DESIGN WHILE MAINTAINING ALL MINIMUM CONTRACT CLEARANCES.
 3. DESIGN-BUILDER TO COORDINATE WITH MASSDOT FOR FUTURE BRIDGE MANUAL INCREASED ALLOWABLE THERMAL MOVEMENT LIMITS FOR USE OF BRIDGE MANUAL STANDARD PAVEMENT SAWCUT DETAILS. DESIGN INTENT IS FOR THE ELIMINATION OF BRIDGE JOINTS.
 4. MINIMUM VERTICAL CLEARANCE AT MWH OCCURS AT THE SOUTHERN EXTERIOR GIRDER AT THE WEST END OF THE STRUCTURE. EXISTING VERTICAL CLEARANCE FROM MWH TO THE BOTTOM GIRDER FLANGE IS 4.92', PROPOSED MINIMUM VERTICAL CLEARANCE IS 7.42'.
 5. THE DESIGN (25 YEAR) FLOOD ELEVATION IS 10.1'. THE BASE (100-YEAR) FLOOD ELEVATION IS 13.7'.

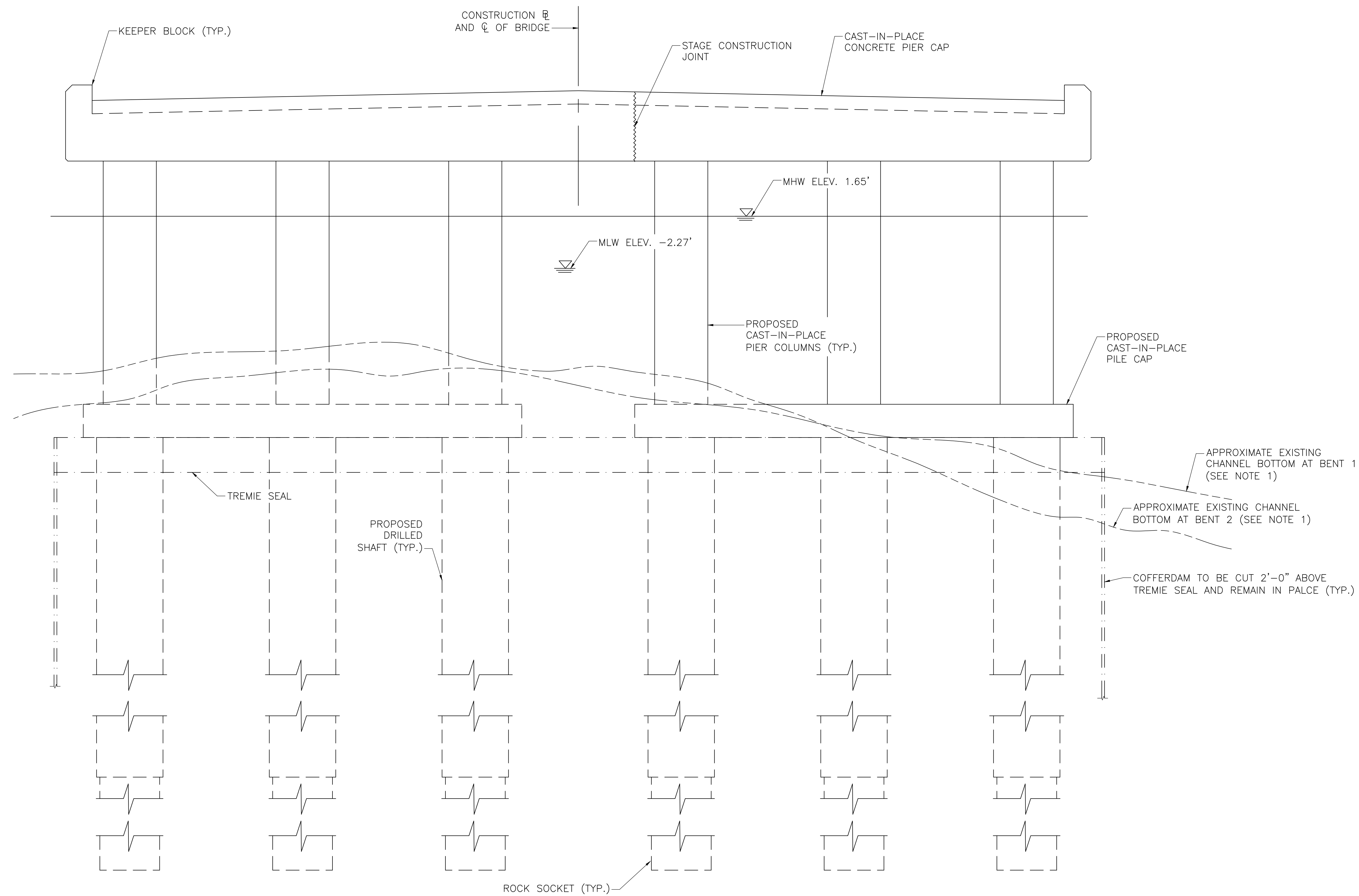

- NOTES:**
1. CHANNEL BOTTOM MATERIAL FROM WITHIN COFFERDAM EXCAVATION SHALL BE STOCKPILED AND REPLACED TO EXISTING CONDITION UPON COMPLETION OF SUBSTRUCTURE CONSTRUCTION PRIOR TO REMOVAL OF COFFERDAM.

TRANSVERSE SECTION OF PIER
SCALE: $\frac{1}{4}$ " = 1'-0"

605311_Sketch Plan Submittal (SP3) August-2024
605311_SK23_BRW06016.DWG Plotted on 10-Sep-2024 8:20 AM

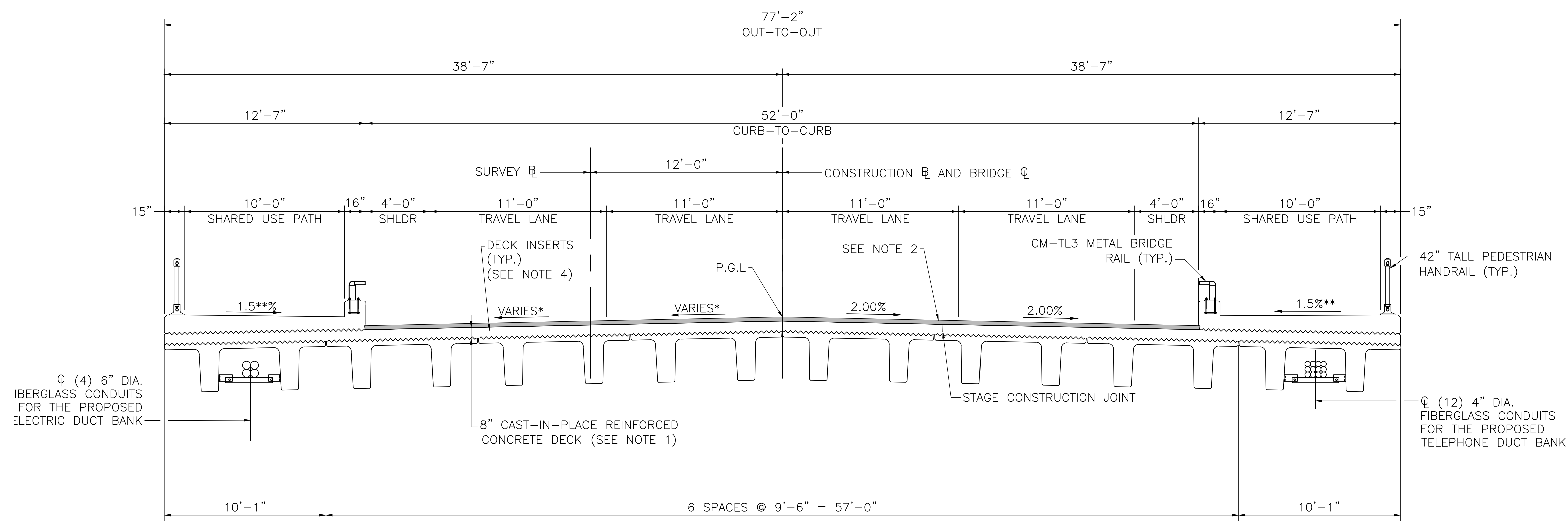

TRANSVERSE SECTION
SCALE: 1/4" = 1'-0"

- NOTES:**
1. DECK THICKNESS VARIES DUE TO SUPPERELEVATION RUNOUT OVER BRIDGE. APPROXIMATE THICKNESS RANGES FROM 8" TO 12".
 2. 1 1/2" SUPERPAVE BRIDGE SURFACE COURSE OVER 1 1/2" SUPERPAVE BRIDGE PROTECTIVE COURSE OVER SPRAY APPLIED MEMBRANE WATERPROOFING.
 3. * 0.014% AT EAST ABUT.
0.00% AT PIER
2.00% AT WEST ABUT.
 - ** 2.00% AT EAST ABUT.
2.00% AT PIER
2.00% AT WEST ABUT.
 4. DECK INSERTS PROVIDED FOR POSSIBLE FUTURE ROAD DIET.
 5. ***SLOPES TO MATCH HIGHWAY DRAWINGS.
 6. BASE TECHNICAL CONCEPT DIMENSIONS SHOWN ARE APPROXIMATE. DESIGN-BUILDER TO ADJUST AS REQUIRED BY FINAL DESIGN WHILE MAINTAINING ALL MINIMUM CONTRACT CLEARANCES.

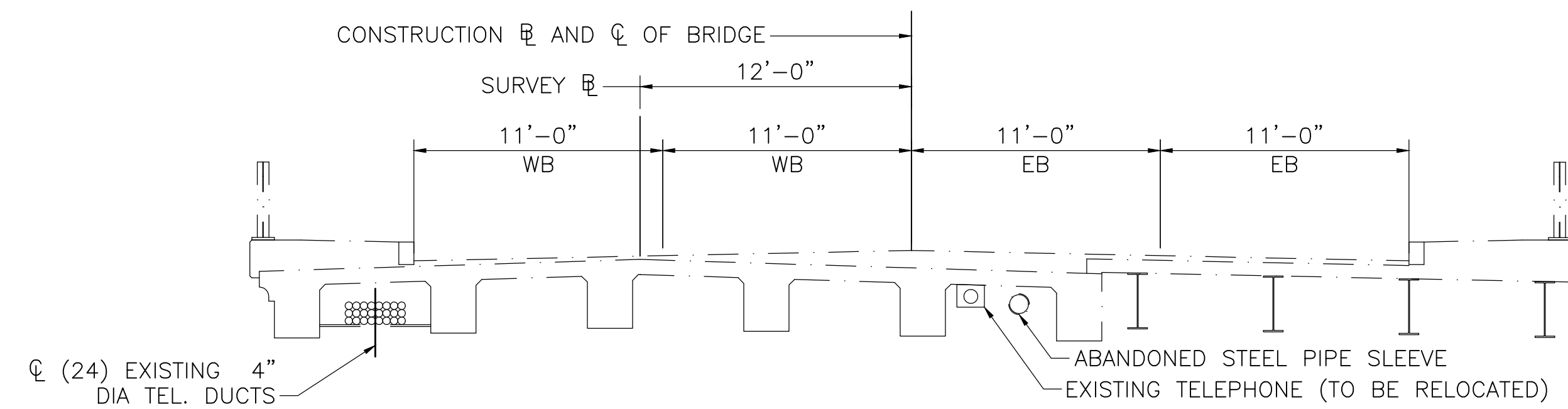

EXISTING CONDITION

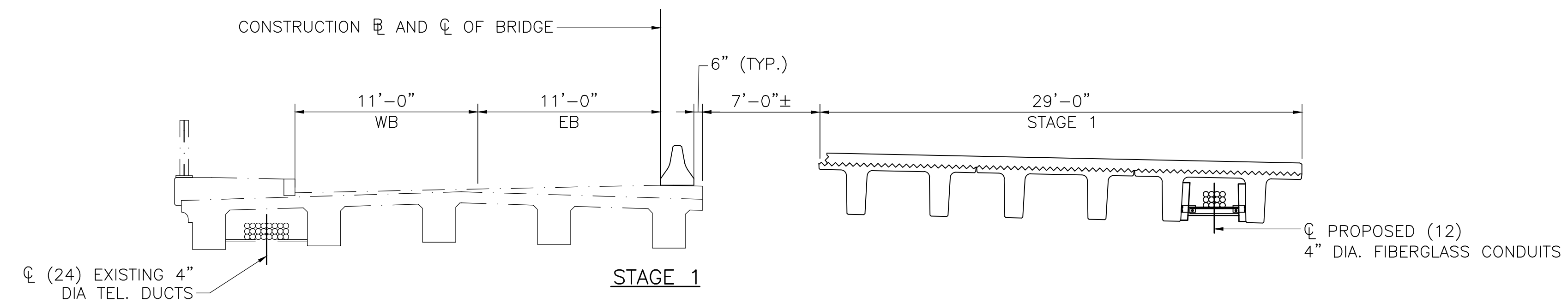

STAGE 1

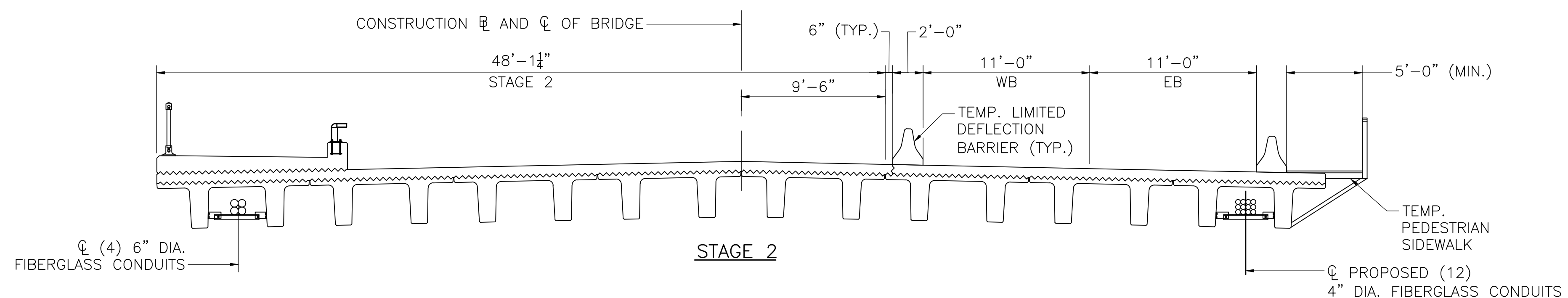

STAGE 2

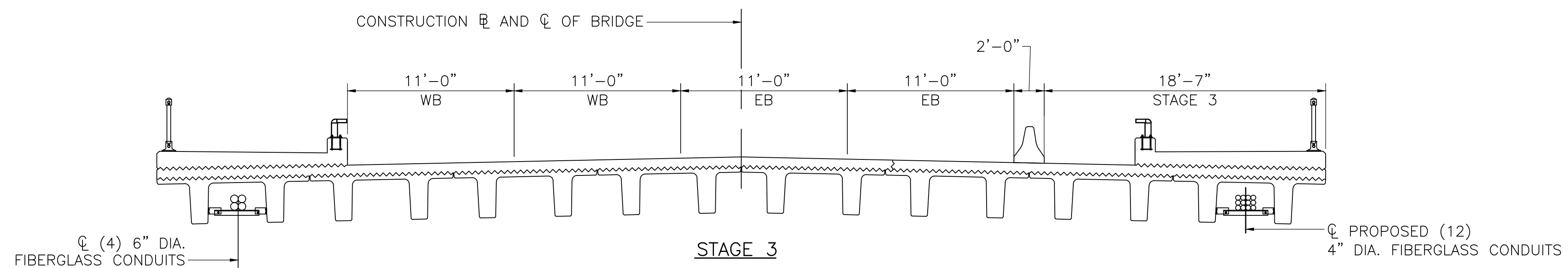

STAGE 3

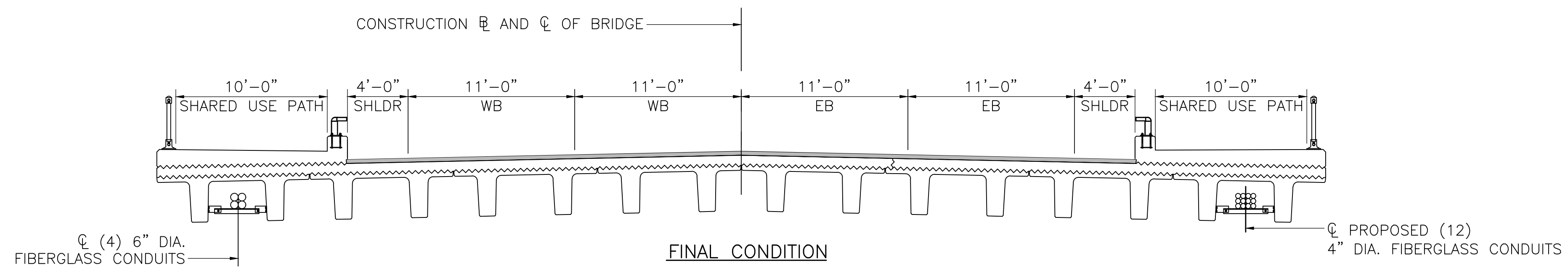

FINAL CONDITION

CONSTRUCTION STAGING

SCALE: 3/8" = 1'-0"

NOTES:

1. STAGING TEMPORARY UTILITY SUPPORT AND UTILITY RELOCATION PLAN SHOWN IS CONCEPTUAL. DESIGN-BUILDER TO BE RESPONSIBLE FOR PROJECT STAGING AS PART OF FINAL DESIGN. STAGING, TEMPORARY TRAFFIC CONTROL AND SEQUENCING TO BE IN ACCORDANCE WITH RFP REQUIREMENTS.
2. TEMPORARY BARRIER SHALL MEET THE REQUIREMENTS OF AASHTO TEST LEVEL 3.

STAGE 1:

- 1.1 RELOCATE EXISTING TELEPHONE INTO EXISTING DUCT BANK, SEE BTC HIGHWAY PLANS.
- 1.2 SHIFT TRAFFIC TO THE NORTH MAINTAINING ONE LANE IN EACH DIRECTION.
- 1.3 DEMOLISH SOUTHERLY PORTION OF EXISTING STRUCTURE.
- 1.4 CONSTRUCT PORTION OF NEW STRUCTURE AS SHOWN.
- 1.4 PLACE SPRAY APPLIED WATERPROOFING MEMBRANE AND 3" PAVEMENT COURSE.
- 1.6 INSTALL 4" DIAMETER FIBERGLASS CONDUITS.
- 1.7 RELOCATED ALL EXISTING TELEPHONE FACILITIES INTO PROPOSED DUCT BANK SYSTEM (BY OTHERS).

STAGE 2:

- 2.1 SHIFT TRAFFIC TO SOUTHERLY PORTION OF NEW STRUCTURE MAINTAINING ONE LANE IN EACH DIRECTION.
- 2.2 DEMOLISH NORTHERLY PORTION OF EXISTING STRUCTURE.
- 2.3 CONSTRUCT REMAINDER OF NEW STRUCTURE AS SHOWN.
- 2.4 PLACE SPRAY APPLIED WATERPROOFING MEMBRANE AND 3" PAVEMENT COURSE.
- 2.5 INSTALL 6" DIAMETER ELECTRICAL CONDUITS.

STAGE 3:

- 3.1 SHIFT TRAFFIC TRAFFIC NORTHERLY MAINTAINING FOUR LANES OF TRAFFIC, TWO IN EACH DIRECTION.
- 3.2 CONSTRUCT SOUTHERLY SHARED USE PATH AND BRIDGE RAIL.

FINAL STAGE:

- REMOVE TEMPORARY BARRIER, MILL FULL BRIDGE WIDTH AND INSTALL FINAL HMA WEARING SURFACE.

NOTES:

FULL DEPTH PAVEMENT:
 SURFACE:
 1 3/4" SUPERPAVE SURFACE COURSE - 12.5 (SSC-12.5) OVER
 INTERMEDIATE:
 2 1/2" SUPERPAVE INTERMEDIATE COURSE - 19.0 (SIC-19.0) OVER
 BASE:
 4 1/2" SUPERPAVE BASE COURSE - 37.5 (SBC-37.5) OVER
 SUBBASE
 4" DENSE GRADED CRUSHED STONE FOR SUB-BASE OVER
 8" GRAVEL BORROW FOR SUB-BASE

NOTES:

1. THE PILE SIZE AND SPACING IS TBD BY THE DESIGN-BUILDER.
2. EXCAVATION AND LIGHTWEIGHT FILL LIMITS SHOWN ARE TYPICAL FOR CAUSEWAY SECTION AND APPROACH SECTION. LIMITS ARE SUBJECT TO CHANGE BASED ON FINAL DESIGN AND EVALUATION OF RETAINING WALL BY THE DESIGN-BUILDER.
3. CAUSEWAY RETAINING WALL, SHEETING AND LIGHTWEIGHT FILL SHOWN ARE BASED ON CONCEPTUAL DESIGN. ALTERNATE WALL SYSTEM CONCEPTS FOR APPROACH ROADWAYS AND CAUSEWAY REQUIRE SUBMITTAL OF AN ATC WHILE MAINTAINING CONFORMANCE WITH RFP REQUIREMENTS.

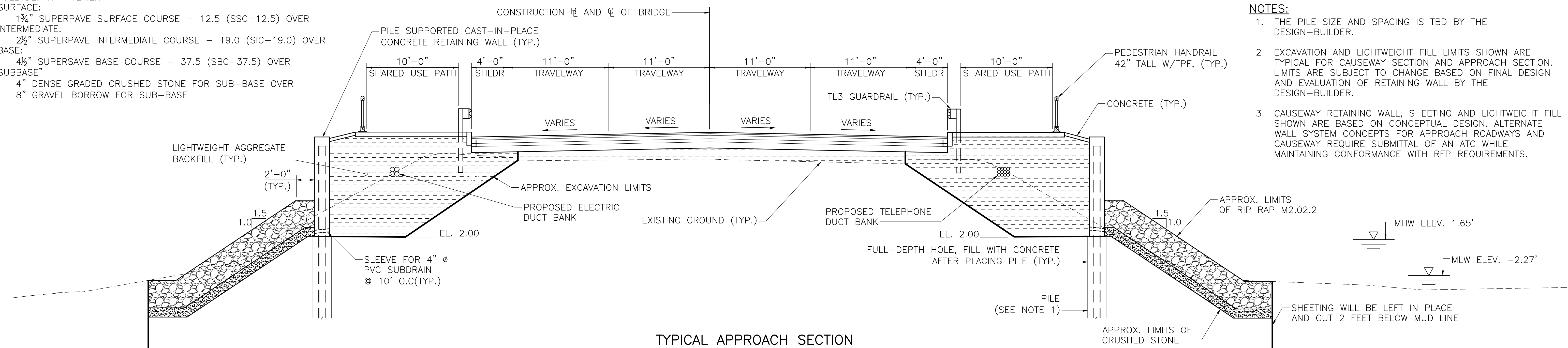

TYPICAL APPROACH SECTION

SCALE: 3/16" = 1'-0"

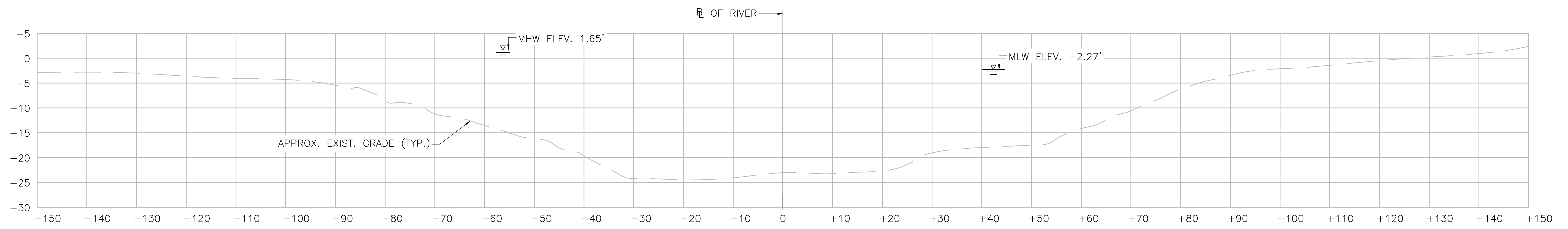

SECTION ACROSS RIVER CL AT STA. 201+38

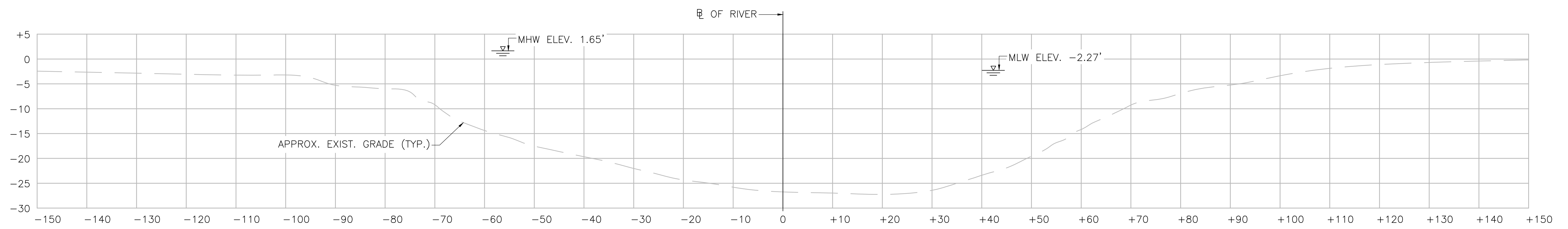

SECTION ACROSS RIVER CL AT STA. 202+62

CHANNEL APPROACH SECTIONS (LOOKING NORTHWEST)

SCALE: 3/32" = 1'-0"

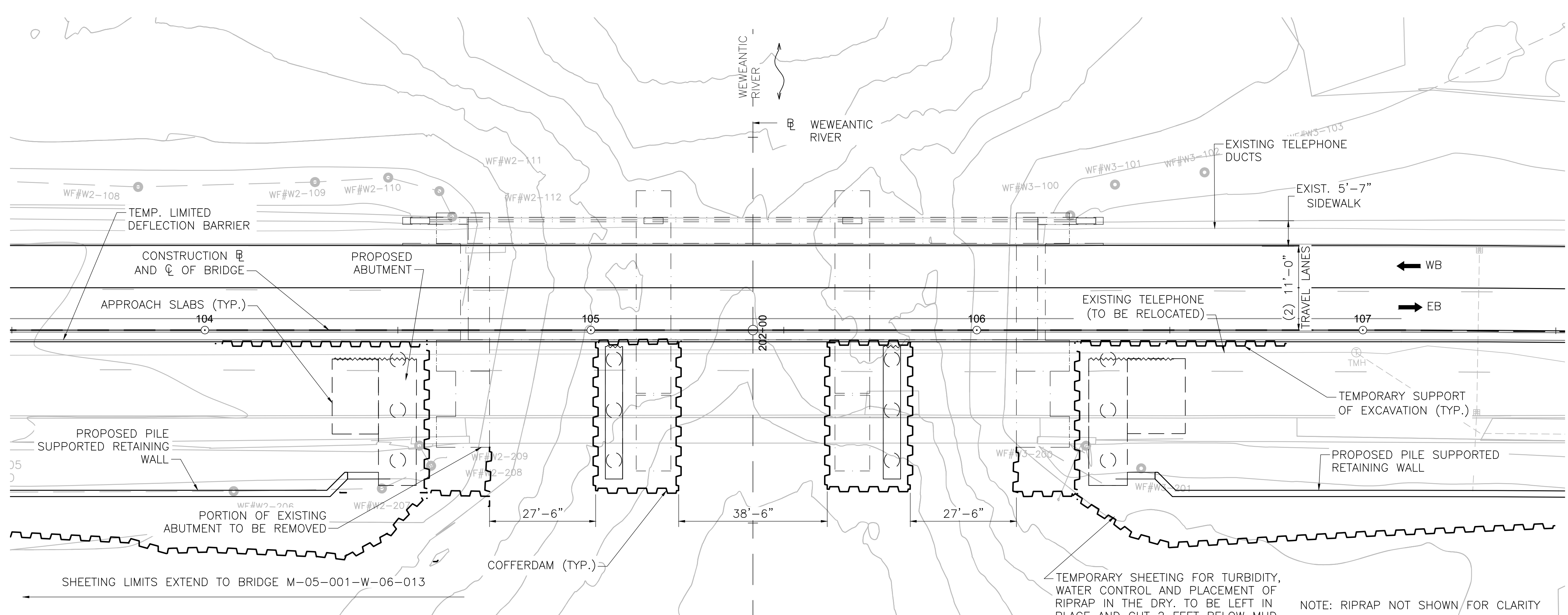
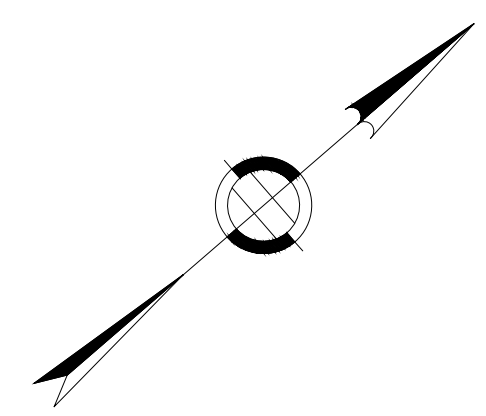

STAGE 1 CONSTRUCTION PLAN
SCALE: 1/16" = 1'-0"

NOTES:

1. BASE TECHNICAL CONCEPT DIMENSIONS SHOWN ARE APPROXIMATE. DESIGN-BUILDER TO ADJUST AS REQUIRED BY FINAL DESIGN.
2. COFFERDAM, SHEETING AND SUPPORT OF EXCAVATION SHOWN IS CONCEPTUAL. DESIGN-BUILDER TO BE RESPONSIBLE FOR PROJECT STAGING, CONSTRUCTION SEQUENCING, LAYOUT OF THE COFFERDAMS, SHEETING AND SUPPORT OF EXCAVATION IN ACCORDANCE WITH THE RFP REQUIREMENTS.

SUGGESTED SEQUENCE OF WATER CONTROL

- STAGE 1:
- 1.1 DEMOLISH SOUTHERLY PORTION OF EXISTING STRUCTURE.
 - 1.2 INSTALL STAGE 1 PIER COFFERDAM AND TEMPORARY SHEETING.
 - 1.3 REMOVE SOUTHERLY PORTION OF PIER AND ABUTMENTS TO SPECIFIED LIMITS.
 - 1.4 CONSTRUCT NEW SOUTHERLY PORTION OF PIER AND INTEGRAL ABUTMENTS.
 - 1.5 REMOVE STAGE 1 PIER COFFERDAM AND TEMPORARY SHEETING.

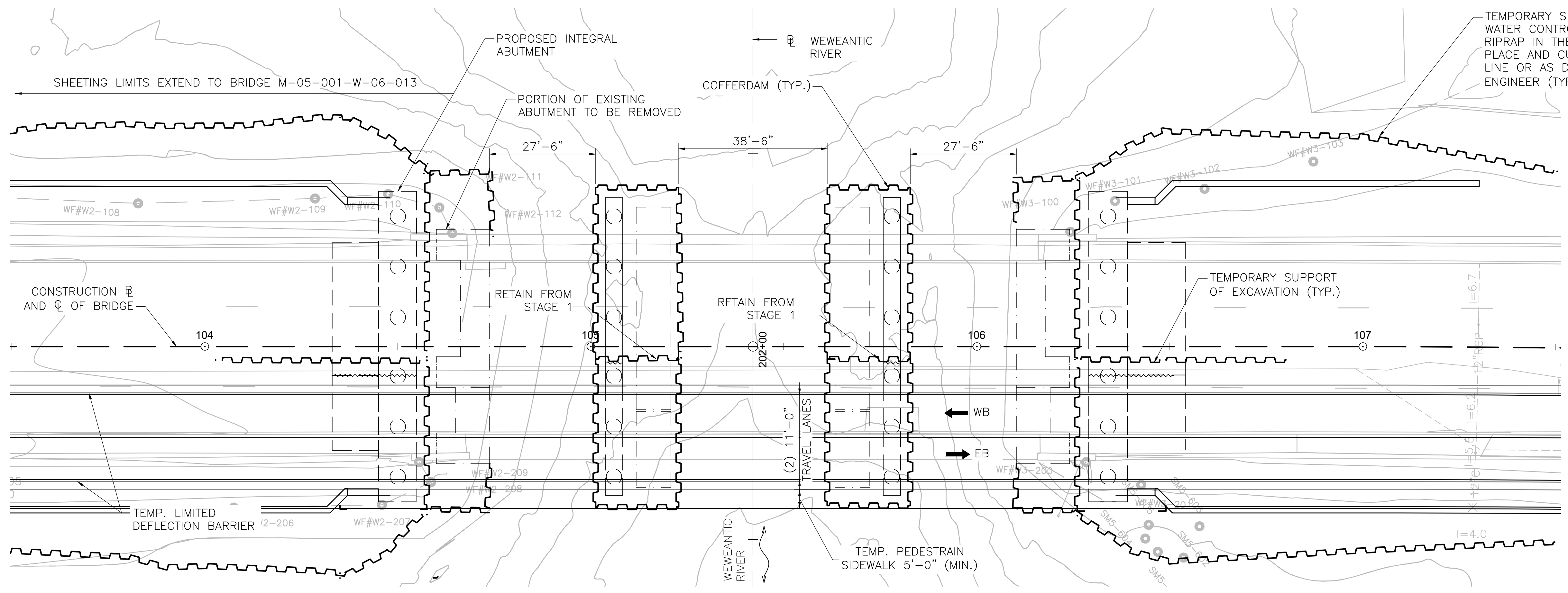

STAGE 2 CONSTRUCTION PLAN
SCALE: 1/16" = 1'-0"

STAGE 2:

- 2.1 DEMOLISH NORTHERLY PORTION OF EXISTING SUPERSTRUCTURE.
- 2.2 INSTALL STAGE 2 PIER COFFERDAM AND TEMPORARY SHEETING.
- 2.3 REMOVE NORTHERLY PORTIONS OF THE EXISTING PIER AND ABUTMENTS TO SPECIFIED LIMITS.
- 2.4 CONSTRUCT NEW NORTHERLY PORTION OF PIER AND INTEGRAL ABUTMENTS.
- 2.5 REMOVE STAGE 2 PIER COFFERDAM AND TEMPORARY SHEETING.

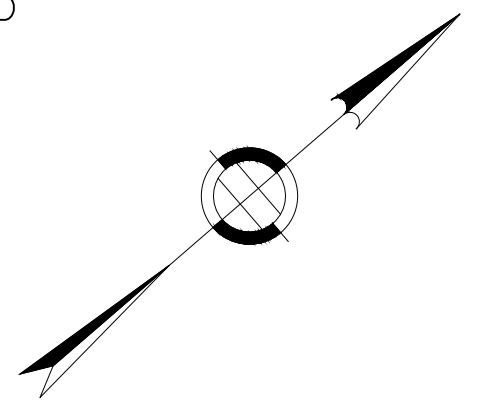

NOTE: RIPRAP NOT SHOWN FOR CLARITY

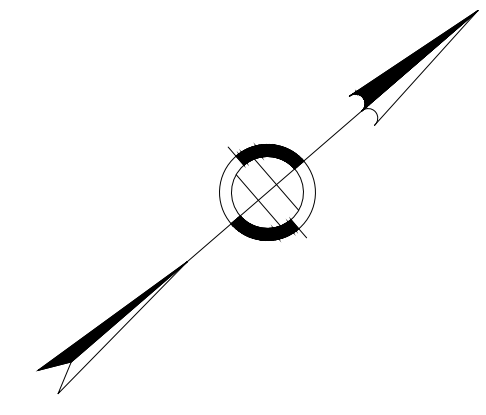
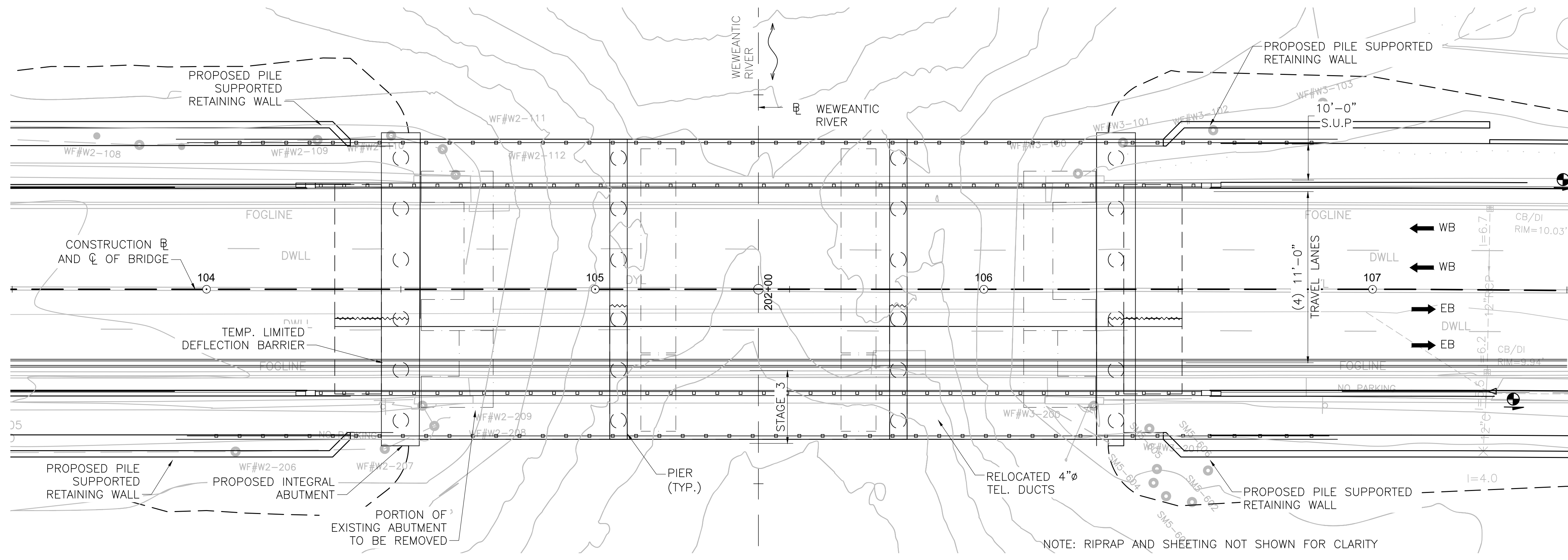

- STAGE 3:
- SHIFT TRAFFIC NORTHERLY MAINTAINING FOUR LANES OF TRAFFIC, TWO IN EACH DIRECTION.
 - CONSTRUCT SOUTHERLY SHARED USE PATH AND BRIDGE RAIL.

STAGING 3 CONSTRUCTION PLAN
SCALE: 1/8" = 1'-0"

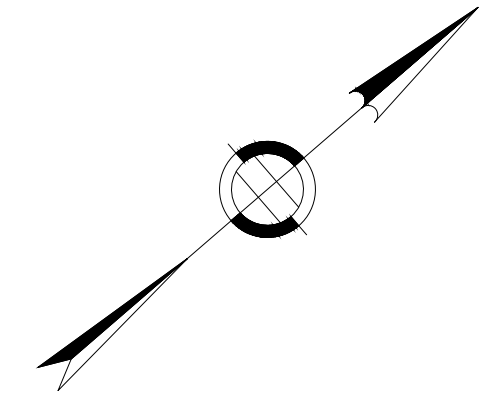
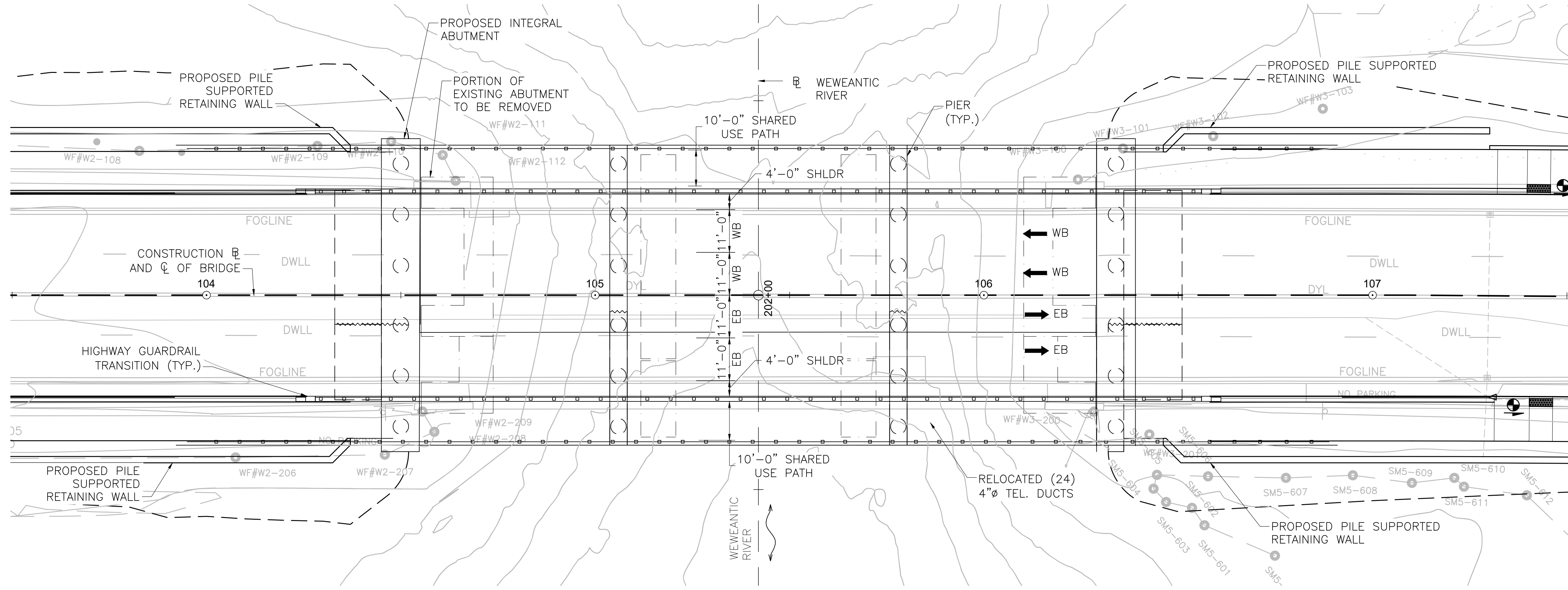

- FINAL STAGE:
- REMOVE BARRIER AND INSTALL SPRAY APPLIED WATER PROOFING MEMBRANE AND HMA WEARING SURFACE.

FINAL CONDITION
SCALE: 1/8" = 1'-0"

NOTE: RIPRAP AND SHEETING NOT SHOWN FOR CLARITY

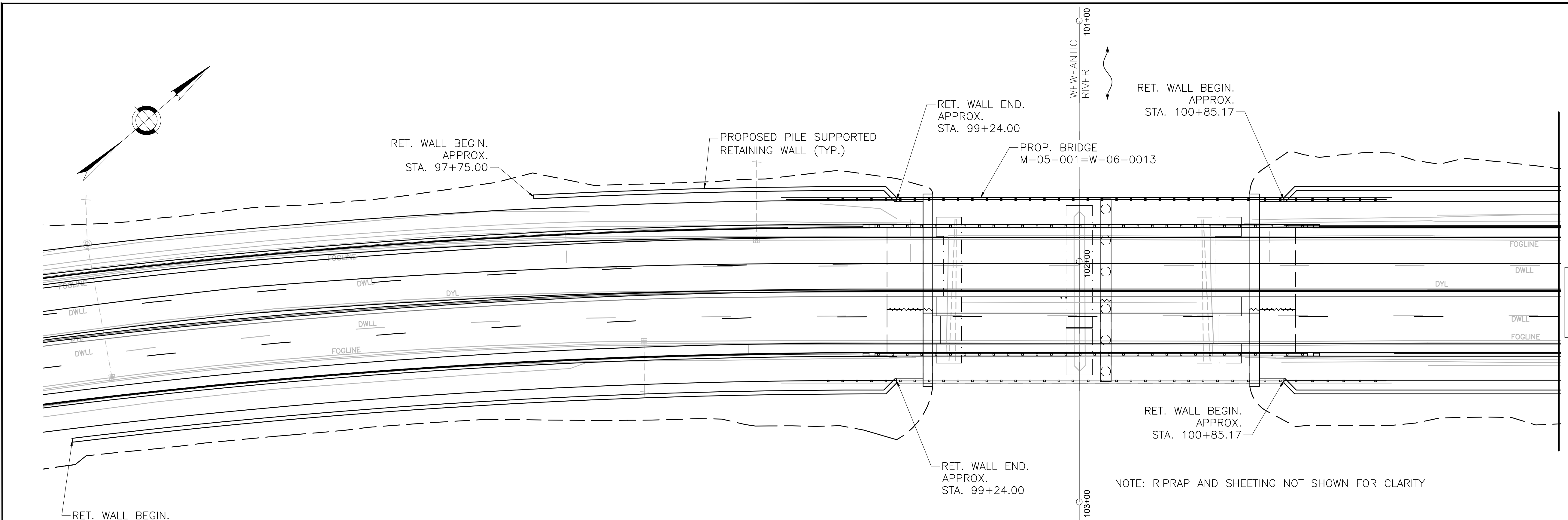

PILE SUPPORTED CONCRETE RETAINING WALL PLAN
NOT TO SCALE

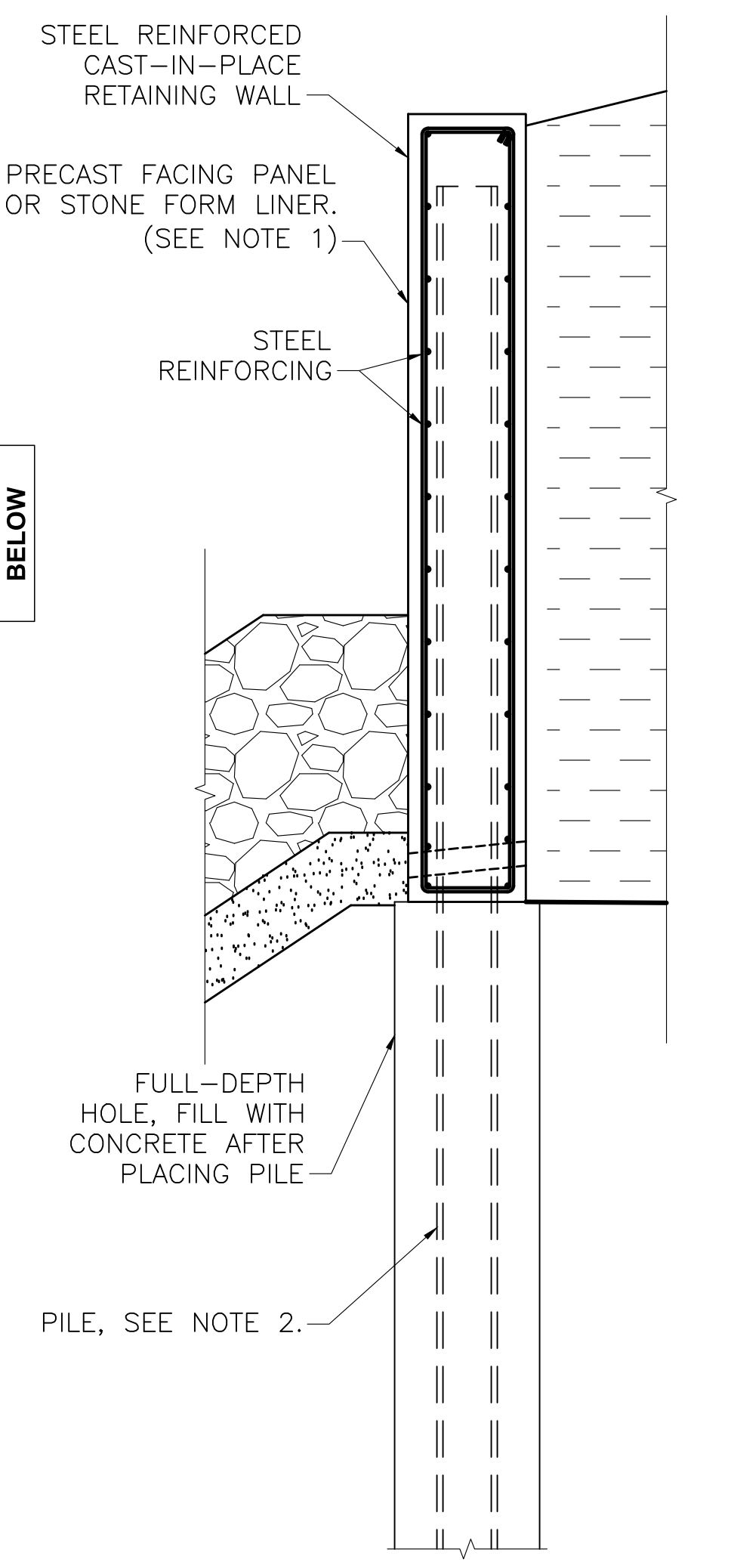

PILE SUPPORTED CONCRETE RETAINING WALL DETAIL
SCALE: 1/2" = 1'-0"

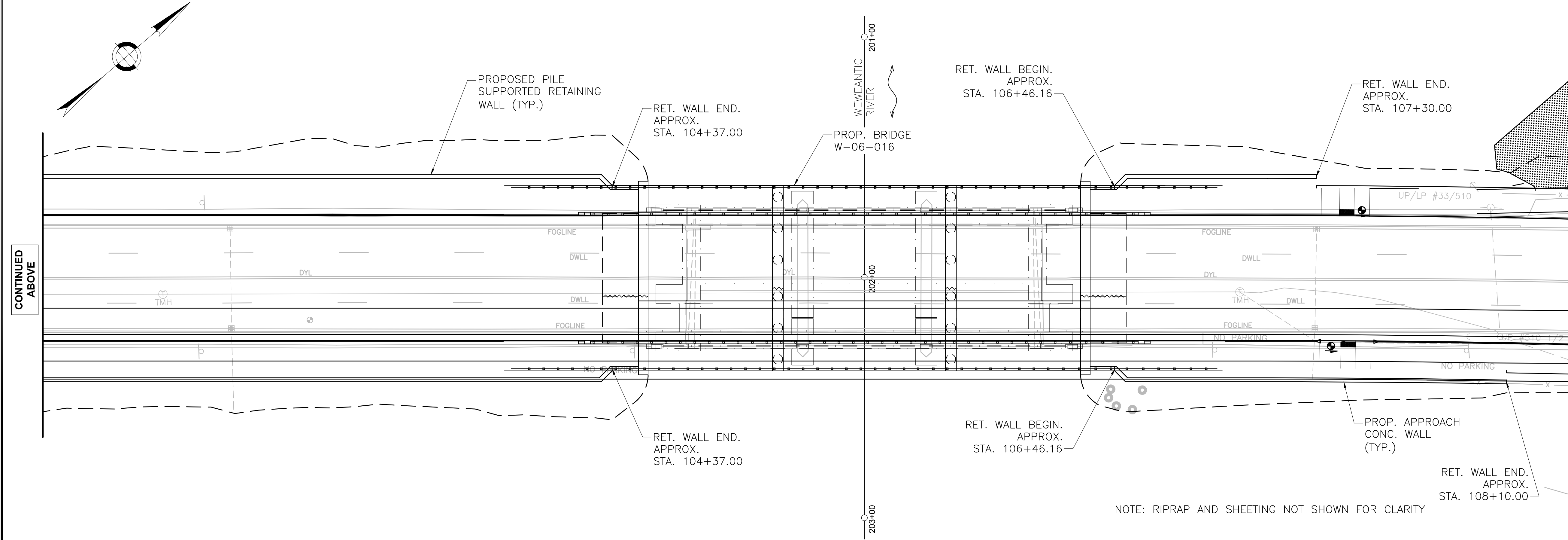

PILE SUPPORTED CONCRETE RETAINING WALL PLAN
NOT TO SCALE

- NOTES:**
1. PRECAST CONCRETE FACING OR STONE TYPE FORM LINER TO PROVIDE AESTHETIC RETAINING WALL FINISH WILL BE EVALUATED FURTHER DURING FINAL DESIGN.
 2. THE PILE SIZE AND SPACING IS TBD BY THE DB ENTITY.
 3. BASE TECHNICAL CONCEPT DIMENSIONS SHOWN ARE APPROXIMATE. DESIGN-BUILDER TO ADJUST AS REQUIRED BY FINAL DESIGN.