



**WORK  
ZONE  
SAFETY**

*Temporary Traffic Control*

*Typical Details and  
Massachusetts Guidelines  
for MassDOT, Municipalities,  
Utilities, and Contractors*

**SHEET INDEX (1 OF 3)**

<b><u>GENERAL</u></b>	<b><u>PAGE</u></b>
NOTES AND GUIDELINES.....	1-9
FIG. 1: TYPICAL TRAFFIC CONTROL DEVICES.....	10
FIG. 2: PAVEMENT EDGE DROP-OFF GUIDANCE.....	11
FIG. 3: TYPICAL DEVICE SPACING; (AT 30 MPH).....	12-13
FLAGGING GUIDANCE.....	14-15
FIG. 4-5: TYPICAL PEDESTRIAN DEVICES.....	16-17
 <b><u>STATIONARY OPERATIONS</u></b>	
FIG. 6: TWO LANE UNDIVIDED ROADWAY; HALF OF ROADWAY CLOSED; WORK NEAR CURVE.....	18-19
FIG. 7: TWO LANE UNDIVIDED ROADWAY; HALF OF ROADWAY CLOSED.....	20-21
FIG. 8: TWO LANE UNDIVIDED ROADWAY; SHOULDER CLOSED.....	22-23
FIG. 9: TWO LANE UNDIVIDED ROADWAY WITH TRAVERSABLE SHOULDER; HALF OF ROADWAY CLOSED; MAINTAIN TWO-WAY TRAFFIC.....	24-25
FIG. 10: FOUR LANE UNDIVIDED ROADWAY; RIGHT LANE CLOSED.....	26-27
FIG. 11: FOUR LANE UNDIVIDED ROADWAY; LEFT LANE CLOSED.....	28-29
FIG. 12: FOUR LANE UNDIVIDED ROADWAY; HALF OF ROADWAY CLOSED.....	30-31
FIG. 13: MULTILANE DIVIDED ROADWAY; RIGHT LANE CLOSED.....	32-33
FIG. 14: MULTILANE DIVIDED ROADWAY; LEFT LANE CLOSED.....	34-35
FIG. 15: MULTILANE DIVIDED ROADWAY; CENTER LANE OR RIGHT/CENTER LANES CLOSED.....	36-37
FIG. 16: MULTILANE DIVIDED ROADWAY; CENTER LANE OR LEFT/CENTER LANES CLOSED.....	38-39

**SHEET INDEX (2 OF 3)**

<b><u>STATIONARY OPERATIONS (CONT.)</u></b>	<b><u>PAGE</u></b>
FIG. 17: MULTILANE DIVIDED ROADWAY; RIGHT SIDE OF OFF RAMP CLOSED.....	40-41
FIG. 18: MULTILANE DIVIDED ROADWAY; LEFT SIDE OF OFF RAMP CLOSED.....	42-43
FIG. 19: MULTILANE DIVIDED ROADWAY; ROADWORK BEYOND ON RAMP.....	44-45
FIG. 20: MULTILANE DIVIDED ROADWAY; ROADWORK BEYOND OFF RAMP.....	46-47
FIG. 21: MULTILANE DIVIDED ROADWAY; TYPICAL RAMP CLOSURE.....	48-49
FIG. 22: MULTILANE DIVIDED ROADWAY; TYPICAL CLOVERLEAF RAMP CLOSURE.....	50-51
FIG. 23: MULTILANE DIVIDED ROADWAY; TYPICAL RAMP CLOSURE; ADVANCE SIGNING.....	52-53
FIG. 24: FOR MULTILANE DIVIDED ROADWAY; PLACEMENT OF TEMPORARY PORTABLE RUMBLE STRIPS.....	54-55
 <b><u>MOBILE OPERATIONS</u></b>	
NOTES FOR MOBILE OPERATIONS.....	56
FIG. 25: ANY ROADWAY; BEYOND RIGHT SHOULDER.....	57
FIG. 26: ANY ROADWAY; SHOULDER.....	58
FIG. 27: DIVIDED ROADWAY; MEDIAN WORK.....	59
FIG. 28: UNDIVIDED TWO LANE ROADWAY; HALF OF ROADWAY CLOSED.....	60
FIG. 29: MULTILANE DIVIDED ROADWAY; LEFT LANE.....	61
FIG. 30: MULTILANE DIVIDED ROADWAY; RIGHT LANE.....	62
FIG. 31: MULTILANE DIVIDED ROADWAY; CENTER LANE.....	63
FIG. 32: POST-STORM CLEANUP OPERATION.....	64

**SHEET INDEX (3 OF 3)**

<b><u>EMERGENCY RESPONSE</u></b>	<b><u>PAGE</u></b>
NOTES FOR TRAFFIC EMERGENCY/INCIDENT OPERATIONS...	65
FIG. 33: ANY ROADWAY; SHOULDER ENCROACHMENT.....	66
FIG. 34: TWO LANE ROADWAY; NO SHOULDER; TRAVEL LANE ENCROACHMENT.....	67
FIG. 35: TWO LANE ROADWAY; TRAVERSABLE SHOULDER; SINGLE LANE ENCROACHMENT.....	68
FIG. 36: TWO LANE ROADWAY; TRAVERSABLE SHOULDER; CENTER OF ROADWAY.....	69
FIG. 37: MULTILANE DIVIDED ROADWAY; RIGHT LANE.....	70
FIG. 38: MULTILANE DIVIDED ROADWAY; LEFT LANE.....	71
FIG. 39: MULTILANE UNDIVIDED ROADWAY; LEFT LANE.....	72
FIG. 40: MULTILANE DIVIDED ROADWAY; MIDDLE LANE; APPROACH FROM LEFT.....	73
FIG. 41: MULTILANE DIVIDED ROADWAY; MIDDLE LANE; APPROACH FROM RIGHT.....	74
 <b><u>TRAFFIC SIGNAL REPAIR WORK AT INTERSECTION</u></b>	
FIG. 42: MULTILANE UNDIVIDED ROADWAY; LEFTMOST OR LEFT TURN LANE.....	75
FIG. 43: TWO LANE UNDIVIDED ROADWAY; ONE LEG OF INTERSECTION.....	76
FIG. 44: MULTILANE UNDIVIDED ROADWAY; CENTER OF INTERSECTION.....	77
 <b><u>PEDESTRIAN DETAILS</u></b>	
FIG. 45: PEDESTRIAN BYPASS.....	78
FIG. 46: TEMPORARY SIDEWALK CLOSURE.....	79
 <b><u>BIKE LANE DETAILS</u></b>	
FIG. 47: BIKE LANE CLOSURE.....	80-81

## INTRODUCTION

This guide has been prepared to assist in the planning and installing of temporary traffic controls in maintenance, utility, or short-term construction work areas (work lasting 10 hours or less). This guide serves to assist with the many decisions that must be made for each work site. Special planning for traffic control is necessary on a case by case basis because conditions can vary widely among work locations. **Since this guide cannot cover every situation, representative illustrations covering typical short-term construction, maintenance, and utility operations are presented.**

**All typical traffic control device setups illustrated should be considered as guides.** The traffic control devices that are shown, the arrangement or position of the devices, and the distances prescribed in the tables are based on the Federal Highway Administration's (FHWA) Manual on Uniform Traffic Control Devices (MUTCD) and the Massachusetts Amendments to the MUTCD (MA Amendments), but these illustrations only present minimum standards. The provision of safe work zones for all roadway users and roadway workers affected by these activities is paramount. Traffic controls may be expanded or improved upon whenever deemed necessary. Traffic movement through the work site all traffic control devices shall be periodically observed and inspected at all locations.

If necessary, Part 6 of the MUTCD and the MA Amendments, Chapter 17 (Work Zone Management) of MassDOT's Project Development & Design Guide, and the "Traffic Engineering and Safety Section" of the MassDOT web site: (<https://www.massdot.state.ma.us/highway/Departments/TrafficandSafetyEngineering.aspx>), as well as MassDOT District offices can provide additional guidance, information, and suggestions for work zone setups.

## RESPONSIBILITIES FOR TRAFFIC CONTROL

Short-term construction, maintenance, and utility work on or near the roadway creates a potentially hazardous situation, typically requiring the use of temporary traffic controls. These controls are important to protect both work crews and the road users. It is the responsibility of each maintenance foreman to establish and maintain safe and effective controls.

Usually the supervisor, working with the crew, plans the traffic control procedures for proposed work sites. The foreman is responsible for re-requesting, storing, and maintaining all traffic control devices necessary for their crews.

The foreman is responsible for placing the devices according to these guidelines. They must inspect each installation and observe traffic flow through the area. The foreman is generally authorized to make adjustments to the original installations that, in their judgment, are necessary to improve the control of traffic and establish greater safety.

All necessary traffic control devices must be installed before work begins and properly maintained during the work period. They must also be removed as soon as they are no longer relevant to the roadway conditions.

PAGE 2

In situations such as night time road or lane closures, detours, or other unusual conditions on state highways, the District Traffic Maintenance Engineer (DTME) should be advised. If the DTME is absent, the section foreman shall follow the instructions of the District Maintenance Engineer.

### **TRAFFIC CONTROL DEVICES**

Traffic control devices regulate the movement of road users, warn of unexpected or unusual roadway conditions, and inform them how to maneuver safely through or around the work area. All signs, channelizing devices, barricades, and other miscellaneous traffic control devices should work together to guide traffic safely and efficiently. Common temporary traffic control devices are outlined and described below.

#### **Signs**

Temporary traffic control zone (TTCZ) signs are the primary means of providing information and directions to roadway users. All signs must be retroreflective per MassDOT's latest standard.

Warning signs call attention to unexpected conditions and to situations that might not be readily apparent to road users on or adjacent to a roadway. Warning signs alert road users to conditions that might call for a reduction of speed or an action in the interest of safety and efficient traffic operations. Nearly all warning signs for construction and work areas have black legends and borders on a fluorescent orange background.

Regulatory signs shall be used to inform road users of selected traffic laws or regulations and indicate the applicability of the legal requirements. Regulatory signs typically have black legends and borders on a white background.

#### **Channelizing Devices**

When used properly, traffic cones, reflectorized plastic drums, and barricades guide traffic through the work area along an appropriate travel path. It takes roadway users a certain distance along the roadway to safely move away from the upcoming active work site. These transition distances are based on the following taper length (L) formulas:

$L = WS^2/60$  for speeds of 40 mph or less; or

$L = WS$  for speeds of 45 mph or more; where

- $L$  = minimum length of taper in feet,
- $S$  = posted speed limit or typical travel speed in miles per hour prior to the work, and
- $W$  = width of lane closure in feet.

The spacing of channelizing devices (in feet) is approximately equal to the existing speed of traffic (in mph).

#### **Warning Lights**

Rotating beacons and other flashing lights mounted on work vehicles, signs, or channelizing devices help alert roadway users to the work area. They may also be used to warn roadway users of hazards within the work area. The first 10 drums in any taper shall be equipped with sequential flashing lights.

### **Arrow Boards**

Arrow boards are a special type of sign that are highly visible work zone warning devices. They are particularly effective on highways, where both speed and volume are high. Arrow boards in the non-directional, CAUTION, mode (four corner flashing) may be used to indicate that a shoulder is closed. Arrow boards in the arrow mode shall only be used when a travel lane is dropped on a multi-lane road and one lane of traffic must merge with another. All arrow boards should be located at the beginning of each lane or shoulder closure taper without extending outside of it. Arrow boards shall flash at a rate of 25 to 40 flashes per minute. Arrow boards shall not be used to indicate a lane shift.

### **BASIC REQUIREMENTS**

In every work situation, the temporary traffic control setup must: Give roadway users sufficient advance warning of the work area; advise roadway users of the proper actions to take and travel paths to follow; and provide protection to roadway users, workers, and the work area. These three general requirements can be met as outlined below.

#### **Provide Advance Warning**

Warning devices along the approaches to a work area alert roadway Users to changes to road and operating conditions. Roadway users are usually alerted to these dangers via a sign or series of signs installed in the same order as the roadway user generally would expect to see them on long-term construction projects.

The initial project limit sign is usually a general warning such as "ROAD WORK 1500 FT". Other operational warning signs then provide the roadway user with more specific information about the situation. A minimum of three advance warning signs (the initial project limit sign and two operational warning signs) is recommended when work is located on the traveled way. Warning lights and flags can be used to attract attention to the signs. A highly visible work area helps reinforce the advance warnings.

#### **Advise and Direct Travelers**

Operational warning signs provide information to the road-way user such as the type of work being performed, special conditions to watch for, or actions to take. These include signs such as, SHOULDER WORK, RIGHT LANE CLOSED, DETOUR 500 FT, ROAD CLOSED to THRU TRAFFIC, POLICE OFFICER AHEAD, etc. All of these signs must be located far enough in advance of the work area that the roadway user has sufficient time to react to them appropriately. For projects in Urban Areas, see detail: Typical Device Spacing for minimum sign spacing.

#### **Protect Travelers, Workers, and the Work Area**

The primary protection of any work area is its own visibility. Traffic cones, reflectorized plastic drums, portable breakaway barricades, etc. are used to make the work area visible and separate workers from traffic.

PAGE 4

Other devices, such as flashing lights, flags, delineators, temporary lighting, and portable changeable message signs (PCMS) can be used to provide additional emphasis and visibility.

Workers must protect themselves by being alert to their work situation, wearing safety vests and hard hats, and by facing traffic whenever possible.

Work vehicles can also add protection when they are equipped with truck mounted attenuators, rotating beacons, flashing lights, flashing arrow boards, etc. and are parked between workers and oncoming traffic. However, workers should not position themselves between two closely parked vehicles. No private personal vehicles are allowed within the work site.

### PLANNING GUIDELINES

Decisions regarding selection of work area traffic control devices require a knowledge and understanding of the specifics of each work zone. As there may be vast differences between situations, three main variables need to be considered prior to determining the need for, or the selection of, traffic control devices: 1) location of work, 2) type of roadway, and 3) speed of traffic.

Compiling information about these variables will help with planning a safe work area control. Each of these variables is explained below.

#### Location of Work

The choice of traffic controls needed for a short-term construction, maintenance, or utility operation depends upon the work zone's location. As a general rule, the closer the active work site is to the roadway, the more control devices are needed. Work can take place:

- Away from the shoulder or edge of pavement. No special devices are needed if work is confined to an area 15 or more feet from the edge of the shoulder. A general warning sign, such as ROAD WORK AHEAD, should be used if workers and equipment must occasionally move closer to the roadway.
- On or near the shoulder/ edge of pavement. This area should be signed as if work were on the road itself, since it is part of the roadway users' recovery area. Advance warning and operational signs are needed, as well as channelization devices to direct traffic and keep the work area visible to roadway users.
- On the median of a divided highway. Work in this location may require traffic control in both directions of traffic. Advance warning and channelization devices should be used if the median is narrow.
- On the roadway. This condition requires detailed protection for workers and sufficient warning to roadway users. Advance warning must provide a general message that work is taking place as well as information about specific hazards and specific actions the roadway user must take.

### TYPE OF ROADWAY

The characteristics of the roadway also have an important influence on the selection of work area traffic control. The roadway, itself, may present special hazards. You should plan for maximum protection, using the worst hazard present as your guide to signing the work area. Some general considerations are described below for road conditions.

**One-way roads:** A one-way road requires signage on both sides of the road if it carries two or more lanes in one direction, ensuring roadway users in all lanes are alerted and informed.

#### Two-way roads:

- **Undivided:** Two-way, undivided roads will usually require controls for both directions of traffic. When the active work site is well off the roadway, controls for the opposite lane may be eliminated.
- **Divided:** Work on divided multi-lane roadways can often be handled as work along a one-way road (i.e. signs are provided along both sides of the roadway along the direction affected). If the work is in the median, both directions of traffic must be controlled, and both approaches should be double signed (i.e. have all 3 advance warning signs on both sides of each direction).

### EFFECTS OF SPEED ON WORK ZONES

Speed is an important consideration in the use of work area traffic control devices. As a general rule, the greater the speed of traffic approaching a work area, the greater the size, number, and spacing of control devices.

**Size.** The standard size for most warning signs is 36 x 36 inches on conventional roadways and 48 x 48 inches on freeways and expressways. Signs larger than the standard 36 x 36 inches may be desirable on high-speed conventional roads.

**Position.** Install signs far enough in advance of the work area so the roadway users have time to react to them (see charts associated with diagrams for spacing).

### OTHER FACTORS

**Sight Obstructions.** To ensure safety, work areas must be visible. Assess the placement of the temporary traffic control devices by driving through the area, and determine if the devices can be easily seen and provide sufficient time for roadway users to react in a safe manner. Extra precaution should be enacted in areas where horizontal or vertical curves may obstruct a roadway user's clear view of road activities ahead.

**Police/Flaggers.** It should be noted that the MUTCD does not require police/flaggers for stationary setups. If police/flaggers are used, a police/flagger ahead sign should be used in advance of any point where the police/flagger is stationed to control road users.

## PROCEDURES FOR WORK AREA TRAFFIC CONTROL

### 1. PLAN YOUR WORK

**Inspect** location of work area and its surroundings.

#### **Analyze:**

- Location of work in relation to the traveled way, intersecting road-ways, driveways, and sight distances;
- Type of roadway and traffic involved; and
- Volume and speed of traffic.

**Meet and discuss** the work and necessary traffic control with the crew.

**Study** representative illustrations in this guide to develop a temporary traffic control plan (TTCP).

#### **Other Considerations:**

- Base your traffic control plan on the premise that all roadway users are unfamiliar with the area.
- The closer the work area location is to traffic, the more controls are needed.
- Plan for maximum protection.
- Select and inspect the temporary control devices needed (including all warning signs), if they are not in good condition, REPLACE THEM!
- Then collect and transport them to the work site.
- Determine their proper placement.
- Install signs and other traffic control devices prior to allowing personnel or equipment onto the roadway.
- Make sure signs are reflective, accurate, clean, and meet specifications. Completely cover any existing permanent signs that will conflict with the messages of the new work area control signs.

### 2. INSTALLING/REMOVING TEMP. TRAFFIC CONTROL DEVICES

Care must be exercised when installing and removing temporary traffic control (TTC) devices. The traffic control needed to perform the operation safely is dictated by the location on the roadway the operation will occur: in a shoulder or a lane, in the left lane or right, etc. In all cases, installing TTC begins and ends as a mobile operation.

A shadow vehicle with a truck mounted attenuator (TMA) shall be used to protect workers installing and removing TTC devices on all roadways with a posted speed limit of 45 MPH or greater as directed by the engineer. TTC devices shall not be installed or removed from a shadow vehicle with a TMA. TTC devices shall be installed or removed from a work operation vehicle only and a shadow vehicle with a TMA shall be used to protect the workers installing or removing the devices.

## **PROCEDURES FOR WORK AREA TRAFFIC CONTROL (CONT.)**

### **3. INSTALL TRAFFIC CONTROL DEVICES AT WORK SITE FOR LOWER SPEED ( $\leq 40$ MPH) ROADWAYS:**

- 1) All devices shall be installed in order with the flow of traffic.
- 2) Where one direction of traffic is being affected, the first sign installed should be the sign farthest from the work site, and on the same side as the work.
- 3) Where two directions of traffic are affected, install signs for opposing traffic first, starting with the sign farthest from the work area. When signs for opposing traffic have been installed, install signs on the same side as the work area, again beginning with the sign farthest from the active work site.
- 4) Once signs are in place, other traffic control devices shall be installed in the same manner as the signs.

### **FOR HIGHER SPEED ( $\geq 45$ MPH) ROADWAYS:**

- 1) All devices shall be installed in order with the flow of traffic.
- 2) Install all advance warning signs, beginning with the ROAD WORK XXX (W20-1) sign and ending with the END ROAD WORK/DOUBLE FINES END (MA-R2-10E) sign.
- 3) Install all signs beginning with the opposite side which will be closed (for a right lane closure; first, install all signs on the left side (shoulder) and then install all signs on the right side (shoulder). No signs shall be erected on the roadway unless delineated by traffic control devices.
- 4) If required, install shoulder taper as the mobile operation advances.
- 5) Install arrow board on the shoulder prior to the merging taper or as close to the beginning of the merging taper as possible.
- 6) Install channelizing devices to form a merging taper. Use of a shadow vehicle with a TMA during installation is required on roads with speed limits of 45 MPH or greater or as directed by the Engineer.
- 7) Install traffic control devices along the buffer space at the appropriate spacing.
- 8) Continue placing devices along the work space at the appropriate spacing.
- 9) Install devices for the termination area as necessary.
- 10) Place the shadow vehicle with a TMA in advance of the first work crew or hazard approached by motorists. Multiple shadow vehicles may be required based on the number of lane and shoulder closures implemented.

### **4. INSPECT WORK AREA SIGNING AND CONTROL DEVICES**

- 1) Assess the placement of the temporary traffic control devices by driving through the work area. All approaches to the work zone should be checked.
- 2) Ensure roadway users will have sufficient time to read signs and react in a safe manner.

### PROCEDURES FOR WORK AREA TRAFFIC CONTROL (CONT.)

- 3) Check visibility of entire work area. If approaching roadway users can't see the work area well, or if they can't see ahead to traffic that may already be queued on the approach because of the work, additional traffic control devices should be deployed.
- 4) Check to ensure the proper temporary traffic control devices are positioned to protect workers from traffic (where possible).
- 5) Ensure all workers wear safety vests, hard hats, and all other necessary safety equipment. All worker safety gear should be in good condition. All reflective gear should be clean and highly visible in the dark.
- 6) Record in the log book the number and location of all signs and devices.

#### Considerations:

- Work area signs should never be blocked from view or obscured by vegetation, existing signs, or other obstructions.
- Flags, flashing lights, and edge line traffic cones can be used to improve visibility.

### 5. REMOVE TRAFFIC CONTROL DEVICES AT WORK SITE

**All workers and equipment should be clear from work site BEFORE removing signs and other devices.**

#### FOR LOWER SPEED ( $\leq 40$ MPH) ROADWAYS:

- 1) Remove signs and other devices within the delineated area when work is complete.
- 2) Remove other traffic control devices in the reverse order in which they were installed
- 3) Remove signs in the reverse order in which they were installed (i.e. sign closest to the work area to be removed first).
- 4) When the operation is complete, uncover any existing permanent signs covered in Step 2.
- 5) Record in the log book the time at which the signs were removed.

#### FOR HIGHER SPEED ( $\geq 45$ MPH) ROADWAYS:

All TTC devices for a stationary lane closure on a multi-lane roadway, except advance warning signs, should be removed against the flow of traffic in the following sequence:

- 1) Remove the channelizing devices starting from the end of the activity area working back to the widest part of the merging taper.
- 2) A shadow vehicle with TMA shall be positioned to protect workers removing devices and work backwards as the setup is removed from the roadway.

### PROCEDURES FOR WORK AREA TRAFFIC CONTROL (CONT.)

- 3) Place the removal vehicle on the shoulder, and remove the channelizing devices from the merging taper by hand onto the work vehicle.
- 4) Remove the arrow board once traffic is clear and it is safe to do so.
- 5) Circle back and moving with the flow of traffic, remove the advance warning signs starting with the opposite side from previous lane closure first.
- 6) At no time shall workers run across the multilane roadway to remove signs on both sides of the road simultaneously.
- 7) Record in the log book the time at which the signs were removed

### RAMP FACILITIES

At all times it is necessary to control the on and off-ramp traffic during the installation and breakdown of traffic control devices. Use of temporary traffic slow-downs or rolling roadblocks is recommended to allow for the safety of workers handing temporary traffic control devices on ramp facilities. A shadow vehicle with a TMA shall be used to protect the workers installing or removing the devices. At no time shall the work operation vehicle be used as the shadow vehicle with the TMA.

### USE OF THIS GUIDE

Illustrations showing minimum standards for short-term construction, maintenance, and utility operations are arranged in this guide by type of operation. The users of this guide should compare all illustrated examples and examine their differences. After gathering information about the work zones using the general guidelines as outlined, proceed as follows:

- 1) Turn to the Index. Consider the type of operations and the type of roadway upon which work will occur.
- 2) Select the figure that most closely matches the conditions where you plan to work. Remember that all diagrams represent minimum standards.
- 3) Read the title of the illustration to ensure that it is appropriate to your location. Study the layout of traffic control devices and read all notes.
- 4) Consult the appropriate tables, as directed on each illustration to determine taper length and proper spacing of signs. Notice that distances change when speeds change. Also note that these are guidelines, only, and they must be adapted to your specific work area.
- 5) Use the **“PROCEDURES FOR WORK AREA TRAFFIC CONTROL”** for assistance in completing all necessary steps to provide effective and safe work area traffic control.



**SIGN**

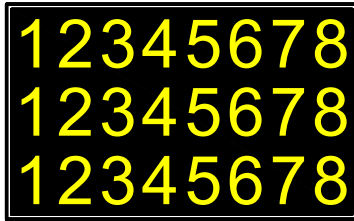

**PORTABLE CHANGEABLE MESSAGE SIGN (PCMS)**

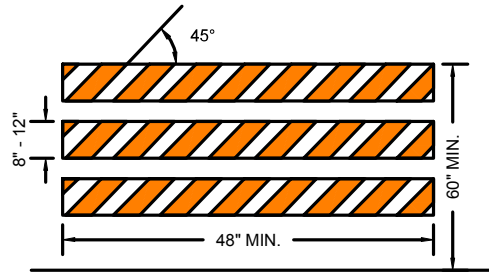

**TYPE III BARRICADE**

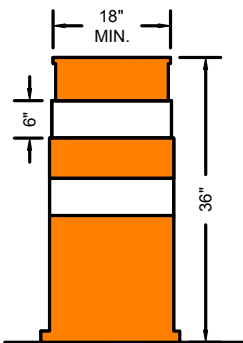

**DRUM**

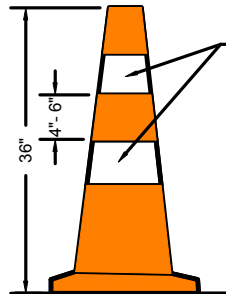

RETROFLECTIVE BANDS

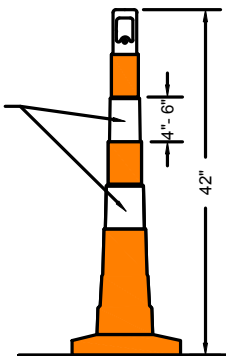

**CONES**

Cones may be used for all daytime operations. For night work, drums should be used to form the taper(s) and cones can be used along the tangent section of the work setup.

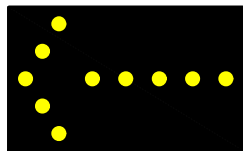

LEFT

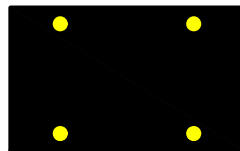

CAUTION

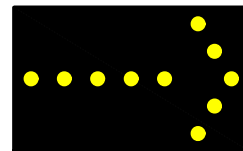

RIGHT

**ARROW BOARD (WITH MODE)**

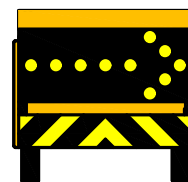

**TRUCK MOUNTED ATTENUATORS**

Truck Mounted Attenuators (TMA) shall be positioned between the start of the work area and the end of the designated buffer zone. The TMAs are to be positioned in each temporarily closed lane. This includes shoulders ( $\geq 8$  feet) whether combined with a travel lane closure or being closed alone. These TMA conditions are required on roadways with speeds of 45 MPH or greater. TMAs can be used on other roadways at the discretion of the engineer. TMAs shall be used for the deployment and removal of all traffic control devices, including all advance warning signs.

### SHORT-TERM PAVEMENT EDGE DROP-OFFS

*Note that this guidance is adopted from the Roadside Design Guide, 4th Edition.*

Pavement drop-offs may occur during paving, excavation, and other construction activities. Drop-offs create hazards for vehicles if not properly mitigated. The following applies for all roads with speed limits greater than 30 mph; for roads with speed limits of 30 mph or less, treatments for pavement edge drop-offs are at the discretion of the Engineer. Drop-offs between adjacent, open travel lanes should not exceed 2", and any drop-off in excess of 3" should not be left unattended without one of these mitigation measures applied.

- Shoulder drop-offs 3" or less adjacent to a shoulder or active travel lane should be mitigated by:
  - ✓ A W8-9 (LOW SHOULDER) sign in advance of and at regular intervals throughout the treatment; or
  - ✓ The placement of drums on the traffic side of the drop-off.

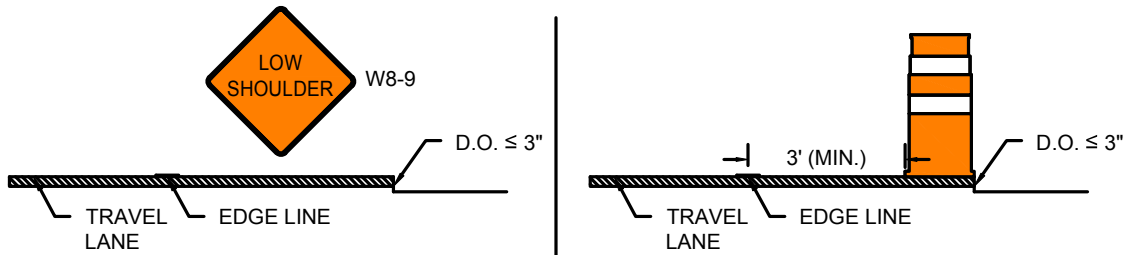

- Shoulder drop-offs greater than 3" but less than or equal to 36" should be mitigated by:
  - ✓ A W8-9 (LOW SHOULDER) sign in advance of and at regular intervals throughout the treatment and the placement of drums on the traffic side off the drop-off, offset at least 3' from the travel lane; or
  - ✓ A W8-9 (LOW SHOULDER) sign in advance of and at regular intervals throughout the treatment and the placement of a temporary wedge of material along the face of the drop-off. The wedge should consist of stable material placed on a 2H:1V or flatter slope.

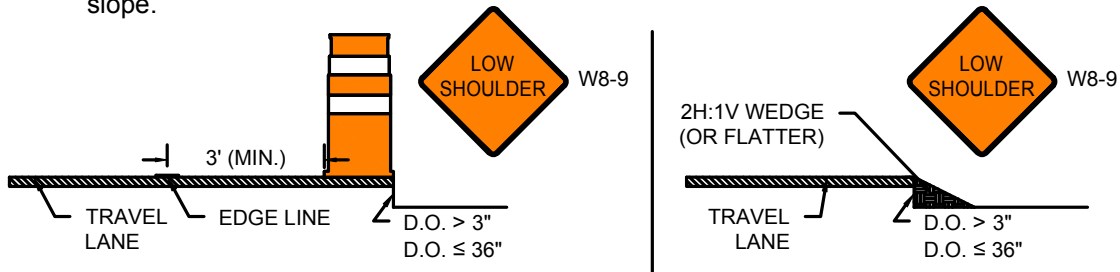

- Shoulder drop-offs greater than 36" must be protected by temporary barrier.

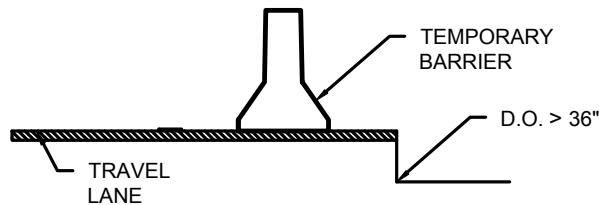

 <p>Massachusetts Department of Transportation Highway Division</p> <p>PAGE 12</p>	Work Zone Safety Standard Details and Drawings	TYPICAL DEVICE SPACING
---	--	------------------------

POSTED SPEED LIMIT (MPH)	SPACING FOR ADVANCE WARNING SIGNS (FT) (A,B,C)	CHANNELIZATION DEVICES (DRUMS OR CONES)			
		TRAVEL LANE CLOSURE LENGTH (L) (FT)	BUFFER ZONE LENGTH (FT)	DEVICE SPACING (FT)	MIN # OF DEVICES*
25-40	500 / 500 / 500	320	305	20	55
45-55	500 / 1000 / 1000	660	495	40	40
60-65	1000 / 1600 / 2600	780	645	40	50









\* NUMBER OF DEVICES BASED ON 400 FT WORK ZONE.

MINIMUM SPACING OF ADVANCE WARNING SIGNS FOR URBAN ROADWAYS	
ROAD TYPE	DISTANCE BETWEEN SIGNS
URBAN (LOW SPEED)	100 FT
URBAN (HIGH SPEED)	350 FT

**NOTES**

1. 40 FT = 10 FT PAVEMENT MARKING + 30 FT SKIP

**LEGEND**

-  WORK ZONE
-  CHANNELIZATION DEVICE
-  FLASHING ARROW BOARD
-  PORTABLE CHANGEABLE MESSAGE SIGN
-  TRUCK MOUNTED ATTENUATOR
-  RADAR SPEED FEEDBACK BOARD
-  POLICE DETAIL OR UNIFORMED FLAGGER
-  TEMPORARY PORTABLE RUMBLE STRIP
-  TYPE III BARRICADE

NOT TO SCALE

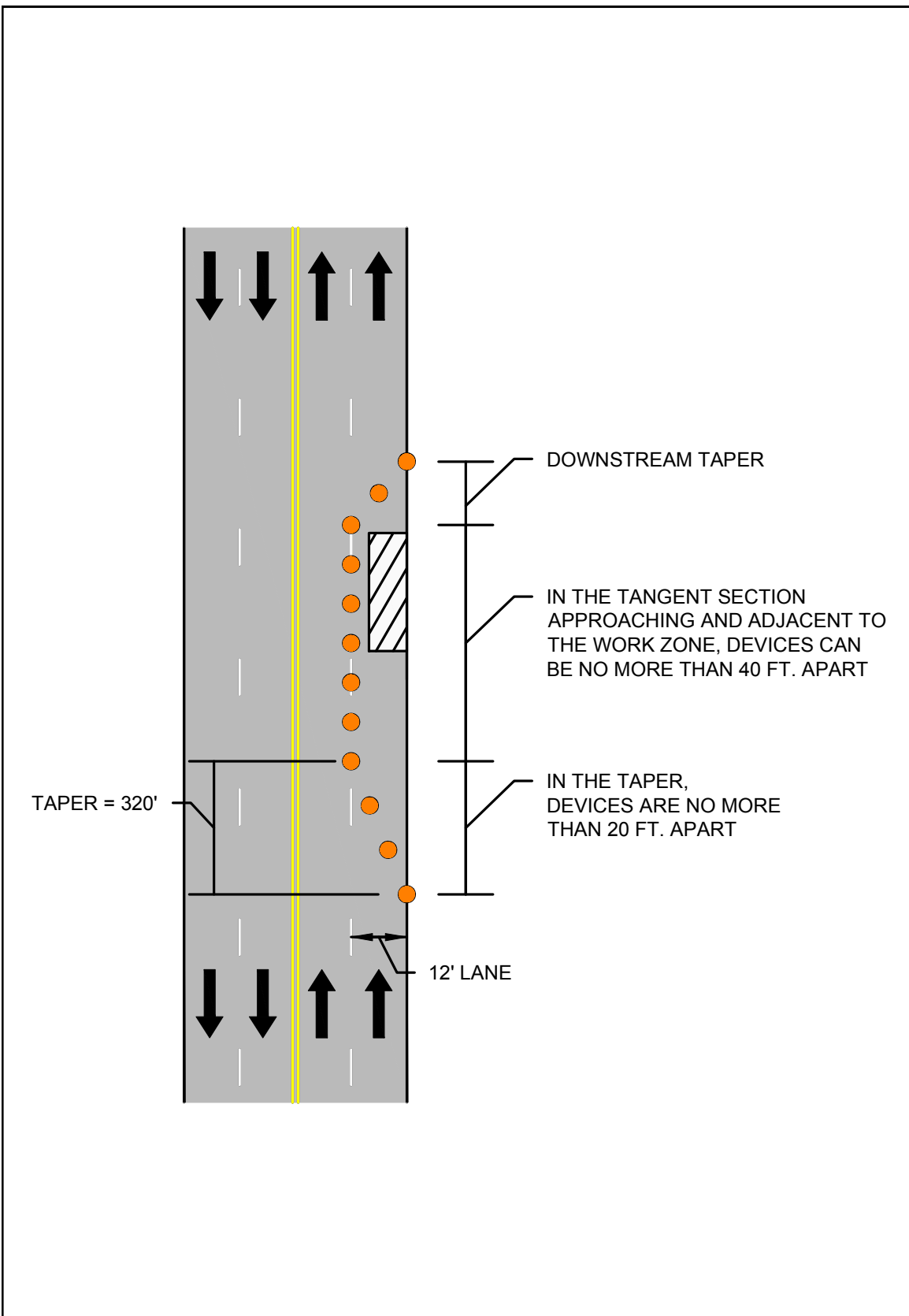

 <p>PAGE 14</p>	<p>Work Zone Safety Standard Details and Drawings</p>	<p>FLAGGING GUIDANCE</p>
--	---	--------------------------

**Guidance for Flagging Operations**

**NOTE:**

A flagger shall always be aware of their surroundings and have a good escape route. A flagger shall never be positioned directly beside or against construction equipment. When a flagger is required to direct traffic in an area where the escape route is partially blocked by a traversable obstruction such as a guardrail, the flagger shall be physically capable of traversing that obstruction. Prior to commencing a project, the supervisor in charge shall review the project, including guardrail areas, for safe flagging stations. The supervisor in charge shall clearly communicate with the flagger(s), indicating any locations where they cannot safely perform their duties.

Each flagger shall be equipped with the following high visibility clothing, signaling, and safety devices:

- 1) A white protective hard hat with a minimum level of reflectivity per the requirements of ANSI, Type I, Class E&G;
- 2) A clean, unfaded, untorn lime/yellow reflective safety vest and pants meeting the requirements of ANSI 107 Class 3 with the words "Traffic Control" on the front and rear panels in minimum two (2) inch (50 millimeter) high letters;
- 3) A 24 inch "STOP/SLOW" traffic paddle conforming to the requirements of Part 6E.03 of the Manual on Uniform Traffic Control Devices (MUTCD), a weighted, reflectorized red flag, flagger station advance warning signage, and two-way radios capable of providing clear communication within the work zone between flaggers, the Contractor, and the Engineer. The traffic paddle shall be mounted on a pole of sufficient length to be seven feet above the ground as measured from the bottom of the paddle;
- 4) A working flashlight with a minimum of 15,000 candlepower and a six inch red attachable wand, a whistle with a working lanyard, and a First Aid kit that complies with the requirements of ANSI Z308.1; and
- 5) An industrial/safety type portable air horn that complies with the requirements of the U.S. Coast Guard.

A "STOP/SLOW" paddle should be the primary hand-signaling device. It shall have an octagonal shape on a rigid handle. Flag use should be limited to emergency situations.



**Properly Trained Flaggers**

- Give clear messages to drivers.
- Allow distance for drivers to react.
- Coordinate with other flaggers.
- Use standard signaling methods.

**Properly Equipped Flaggers**

- Use approved stop/slow paddles.
- Use approved safety apparel.
- Use retroreflective equipment.
- Use hand held radios, as needed.
- All flaggers shall wear safety apparel that meets ANSI Class 3 requirements. The combination of vest and pants is required.

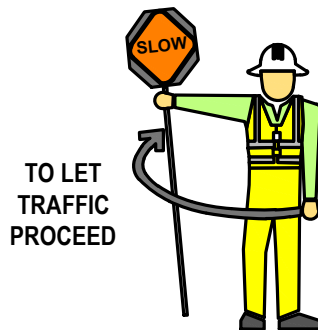

**Proper Flagging Stations**

- Good approach sight distance.
- Highly visible to traffic.
- Stand alone away from other machinery and people.
- Stand on right edge of pavement or shoulder- proceed to centerline only when first vehicle has come to stop.
- Have a good escape route.



**Proper Advance Warning Signs**

- Always use warning signs.
- Allow for reaction distance from signs.
- Remove signs if no longer necessary or not flagging.
- Use free hand in up-and-down motion to help slow traffic.



FIGURE 4  
TYPICAL PEDESTRIAN DEVICES  
(1 OF 2)  
NOT TO SCALE

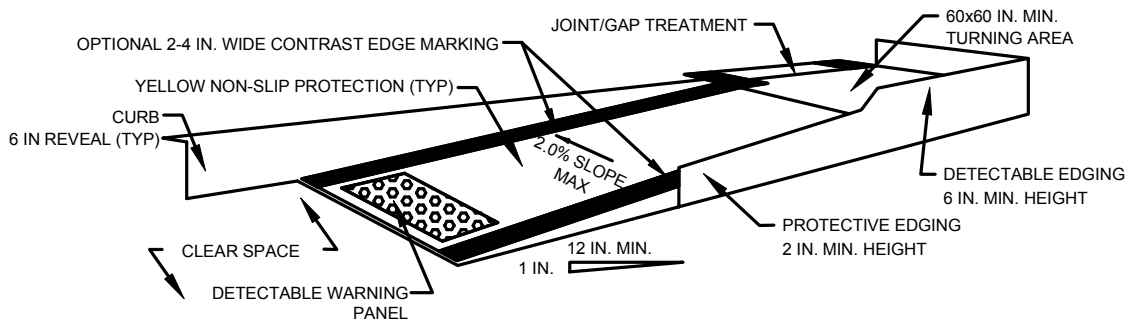

**TEMPORARY CURB RAMP-PARALLEL TO CURB**

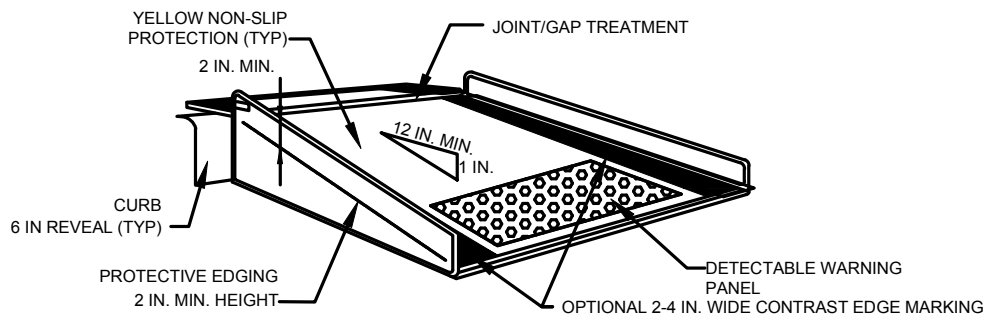

**TEMPORARY CURB RAMP-PERPENDICULAR TO CURB**

**NOTES:**

1. CURB RAMPS SHALL BE 60 IN. MINIMUM WIDTH WITH A FIRM, STABLE, AND NON-SLIP SURFACE.
2. PROTECTIVE EDGING WITH A 2 IN. MINIMUM HEIGHT SHALL BE INSTALLED WHEN THE CURB RAMP OR LANDING PLATFORM HAS A VERTICAL DROP OF 6 IN. OR GREATER OR HAS A SIDE APRON SLOPE STEEPER THAN 1:3 (33%). PROTECTIVE EDGING SHOULD BE CONSIDERED WHEN THE CURB RAMPS OR LANDING PLATFORMS HAVE A VERTICAL DROP OF 3 IN. OR MORE.
3. PROTECTABLE EDGING WITH 6 IN. MINIMUM HEIGHT AND CONTRASTING COLOR SHALL BE INSTALLED ON ALL CURB RAMP LANDINGS WHERE THE WALKWAY CHANGES DIRECTION (TURNS).
4. THE CURB RAMP WALKWAY AND LANDING AREA SURFACE SHALL BE OF A SOLID CONTINUOUS CONTRASTING COLOR ABUTTING UP TO THE EXISTING SIDEWALK.
5. CURB RAMPS AND LANDINGS SHOULD HAVE A 1:50 (2%) MAX CROSS-SLOPE.
6. CLEAR SPACE OF 48x48 IN. MINIMUM SHALL BE PROVIDED ABOVE AND BELOW THE CURB RAMP.
7. WATER FLOW IN THE GUTTER SYSTEM SHALL HAVE MINIMAL RESTRICTION.
8. LATERAL JOINTS OR GAPS BETWEEN SURFACES SHALL BE LESS THAN 0.5 IN. WIDTH.
9. CHANGES BETWEEN SURFACE HEIGHTS SHOULD NOT EXCEED 0.5 IN. LATERAL EDGES SHOULD BE VERTICAL UP TO 0.25 IN. HIGH, AND BEVELED AT 1:2 BETWEEN 0.25 IN. AND 0.5 IN. HEIGHT.
10. IF A TEMPORARY PEDESTRIAN RAMP LEADS TO A CROSSWALK, THEN A DETECTABLE WARNING PAD MUST BE ADHERED TO THE BASE OF THE RAMP. IF IT LEADS TO A PROTECTED PEDESTRIAN BYPASS THAT DOES NOT CONFLICT WITH VEHICULAR TRAFFIC, THEN A PAD SHALL NOT BE INSTALLED ON THE RAMP.

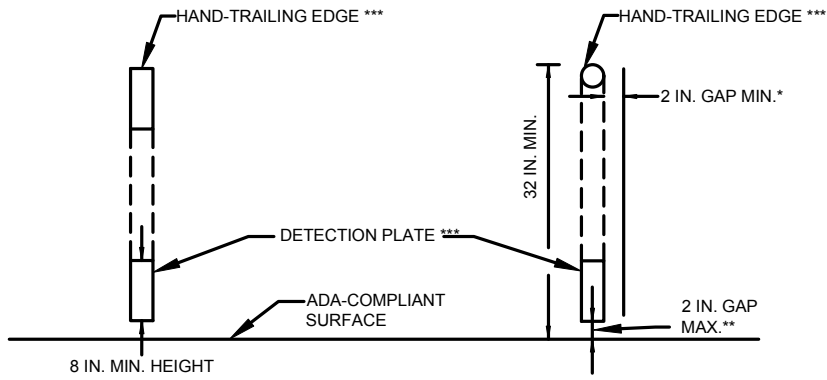

**CROSS SECTION VIEW**

**PEDESTRIAN CHANNELIZING DEVICE**

- \* THERE SHALL BE A 2 INCH GAP BETWEEN THE HAND-TRAILING EDGE AND ITS SUPPORT.
- \*\* A MAXIMUM 2 INCH GAP BETWEEN THE BOTTOM OF THE BOTTOM RAIL AND THE SURFACE MAY BE USED TO PROVIDE DRAINAGE.
- \*\*\* THE HAND-TRAILING EDGE AND DETECTION PLATE SHALL BE CONTINUOUS THROUGHOUT THE LENGTH OF THE PATH SUCH THAT A PEDESTRIAN USER WITH A LONG CANE CAN FOLLOW IT.

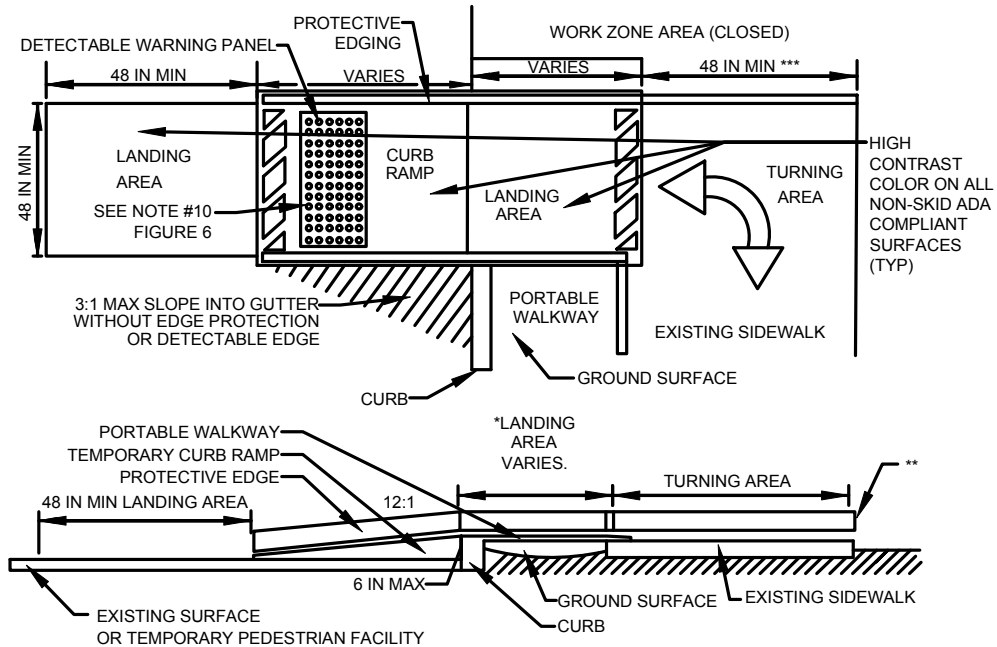

**TEMPORARY CURB RAMP**

- \* LANDING AREA USED TO OVERLAP NON-ADA COMPLIANT SURFACES.
- \*\* DETECTABLE EDGE REMOVED IF A CONTINUOUS SIDEWALK.
- \*\*\* 60 IN. IF AN OBSTRUCTION IS AT BACK OF SIDEWALK.

 Massachusetts Department of Transportation Highway Division	Work Zone Safety Standard Details and Drawings	FIGURE 5 TYPICAL PEDESTRIAN DEVICES (2 OF 2) NOT TO SCALE
PAGE 17		



PAGE 18

Work Zone Safety  
Standard Details  
and Drawings

STATIONARY OPERATIONS  
TWO LANE UNDIVIDED ROADWAY  
HALF OF ROADWAY CLOSED  
WORK NEAR CURVE









POSTED SPEED LIMIT (MPH)	SPACING FOR ADVANCE WARNING SIGNS (FT) (A,B,C)	CHANNELIZATION DEVICES (DRUMS OR CONES)			
		TRAVEL LANE CLOSURE LENGTH (L) (FT)	BUFFER ZONE LENGTH (FT)	DEVICE SPACING (FT)	MIN # OF DEVICES*
25-40	500 / 500 / 500	50	100	20	30
45-55	500 / 1000 / 1000	100	150	40	20

\* NUMBER OF DEVICES BASED ON 400 FT WORK ZONE.

**NOTES**

1. IF POLICE DETAIL/UNIFORMED FLAGGER SUPPORT IS REQUIRED, PROVIDE TWO UNITS.
2. MA-R2-10a LOCATED AT C/2.
3. \*\* = EXTEND ENOUGH SO TAPER IS BEFORE CURVE

**LEGEND**

-  WORK ZONE
-  CHANNELIZATION DEVICE
-  FLASHING ARROW BOARD
-  PORTABLE CHANGEABLE MESSAGE SIGN
-  TRUCK MOUNTED ATTENUATOR
-  RADAR SPEED FEEDBACK BOARD
-  POLICE DETAIL OR UNIFORMED FLAGGER
-  TEMPORARY PORTABLE RUMBLE STRIP
-  TYPE III BARRICADE

NOT TO SCALE





PAGE 20

Work Zone Safety  
Standard Details  
and Drawings

STATIONARY OPERATIONS  
TWO LANE UNDIVIDED ROADWAY  
HALF OF ROADWAY CLOSED

POSTED SPEED LIMIT (MPH)	SPACING FOR ADVANCE WARNING SIGNS (FT) (A,B,C)	CHANNELIZATION DEVICES (DRUMS OR CONES)			
		TRAVEL LANE CLOSURE LENGTH (L) (FT)	BUFFER ZONE LENGTH (FT)	DEVICE SPACING (FT)	MIN # OF DEVICES*
25-40	500 / 500 / 500	50	100	20	30
45-55	500 / 1000 / 1000	100	150	40	20









\* NUMBER OF DEVICES BASED ON 400 FT WORK ZONE.

POSTED REGULATORY OR WORK ZONE SPEED	SEPARATION BETWEEN RUMBLE STRIPS
36-mph to 55-mph	15-feet
35-mph and under	10-feet

**NOTES**

1. IF POLICE DETAIL/UNIFORMED FLAGGER SUPPORT IS REQUIRED, PROVIDE TWO UNITS.
2. MA-R2-10a LOCATED AT C/2.
3. \*\* OPTIONAL AT THE ENGINEER'S DISCRETION.
4. \*\*\* SHALL BE DEPLOYED IF RUMBLE STRIPS ARE PRESENT.

**LEGEND**

-  WORK ZONE
-  CHANNELIZATION DEVICE
-  FLASHING ARROW BOARD
-  PORTABLE CHANGEABLE MESSAGE SIGN
-  TRUCK MOUNTED ATTENUATOR
-  RADAR SPEED FEEDBACK BOARD
-  POLICE DETAIL OR UNIFORMED FLAGGER
-  TEMPORARY PORTABLE RUMBLE STRIP
-  TYPE III BARRICADE

NOT TO SCALE

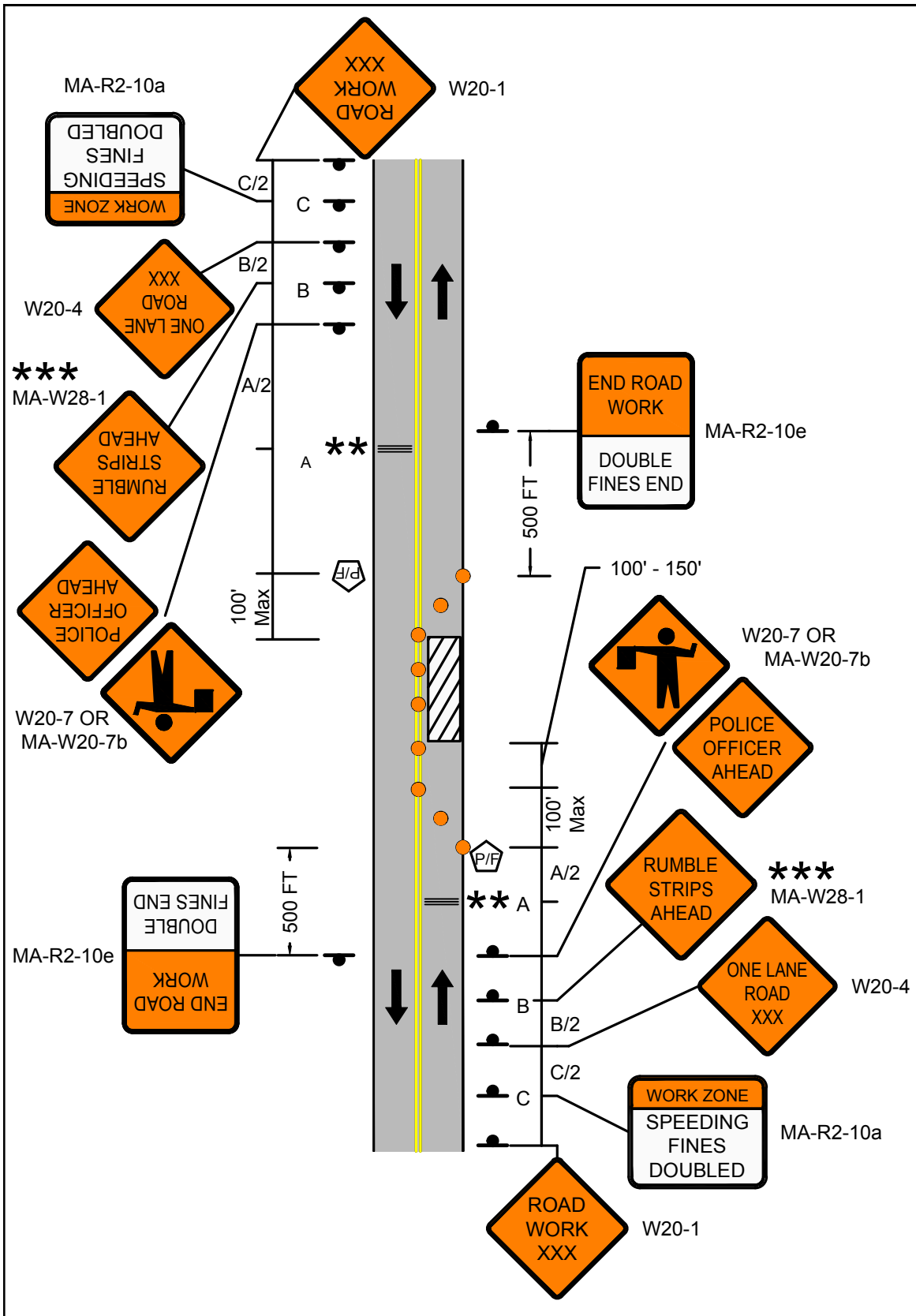

 <p>PAGE 21</p>	<p>Work Zone Safety Standard Details and Drawings</p>	<p>FIGURE 7 STATIONARY OPERATIONS TWO LANE UNDIVIDED ROADWAY HALF OF ROADWAY CLOSED</p>
--	---	---



PAGE 22

Work Zone Safety  
Standard Details  
and Drawings

STATIONARY OPERATIONS  
TWO LANE UNDIVIDED ROADWAY  
SHOULDER CLOSED









POSTED SPEED LIMIT (MPH)	SPACING FOR ADVANCE WARNING SIGNS (FT) (A,B,C)	CHANNELIZATION DEVICES (DRUMS OR CONES)			
		SHOULDER TAPER LENGTH (L/3) (FT)	BUFFER ZONE LENGTH (FT)	DEVICE SPACING (FT)	MIN # OF DEVICES*
25-40	500 / 500 / 500	110	305	20	45
45-55	500 / 1000 / 1000	220	495	40	30
60-65	1000 / 1600 / 2600	260	645	40	35

\* NUMBER OF DEVICES BASED ON 400 FT WORK ZONE.

NOTES

1. MA-R2-10a at C/2 and A/2.

LEGEND

-  WORK ZONE
-  CHANNELIZATION DEVICE
-  FLASHING ARROW BOARD
-  PORTABLE CHANGEABLE MESSAGE SIGN
-  TRUCK MOUNTED ATTENUATOR
-  RADAR SPEED FEEDBACK BOARD
-  POLICE DETAIL OR UNIFORMED FLAGGER
-  TEMPORARY PORTABLE RUMBLE STRIP
-  TYPE III BARRICADE

NOT TO SCALE

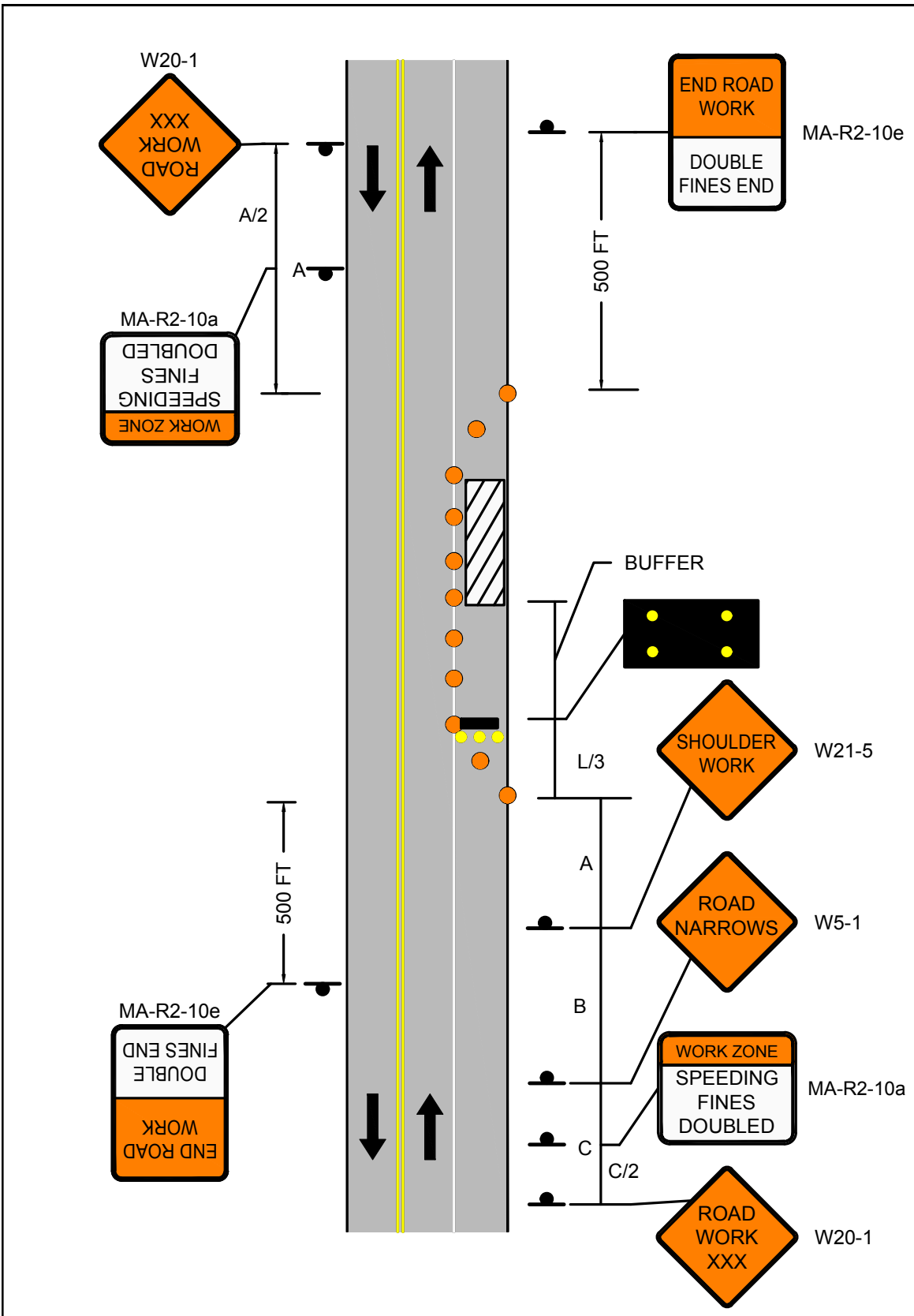

 <p>PAGE 23</p>	<p>Work Zone Safety Standard Details and Drawings</p>	<p>FIGURE 8 STATIONARY OPERATIONS TWO LANE UNDIVIDED ROADWAY SHOULDER CLOSED</p>
--	---	--



PAGE 24

Work Zone Safety  
Standard Details  
and Drawings

STATIONARY OPERATIONS  
TWO LANE UNDIVIDED ROADWAY  
WITH TRAVERSABLE SHOULDER  
HALF OF ROADWAY CLOSED  
MAINTAIN TWO-WAY TRAFFIC

POSTED SPEED LIMIT (MPH)	CHANNELIZATION DEVICES (DRUMS OR CONES)				
	SHOULDER TAPER LENGTH (L/3) (FT)	TRAVEL LANE SHIFT LENGTH (L/2) (FT)	BUFFER ZONE LENGTH (FT)	DEVICE SPACING (FT)	MIN # OF DEVICES*
25-40	110	160	305	20	125
45-55	220	330	495	40	100
60-65	260	390	645	40	115









\* NUMBER OF DEVICES BASED ON 400 FT WORK ZONE.

POSTED SPEED LIMIT (MPH)	SPACING FOR ADVANCE WARNING SIGNS (FT) (A,B,C)
25-40	500 / 500 / 500
45-55	500 / 1000 / 1000
60-65	1000 / 1600 / 2600

**NOTES**

1. MA-R2-10a LOCATED AT C/2.

**LEGEND**

-  WORK ZONE
-  CHANNELIZATION DEVICE
-  FLASHING ARROW BOARD
-  PORTABLE CHANGEABLE MESSAGE SIGN
-  TRUCK MOUNTED ATTENUATOR
-  RADAR SPEED FEEDBACK BOARD
-  POLICE DETAIL OR UNIFORMED FLAGGER
-  TEMPORARY PORTABLE RUMBLE STRIP
-  TYPE III BARRICADE

NOT TO SCALE

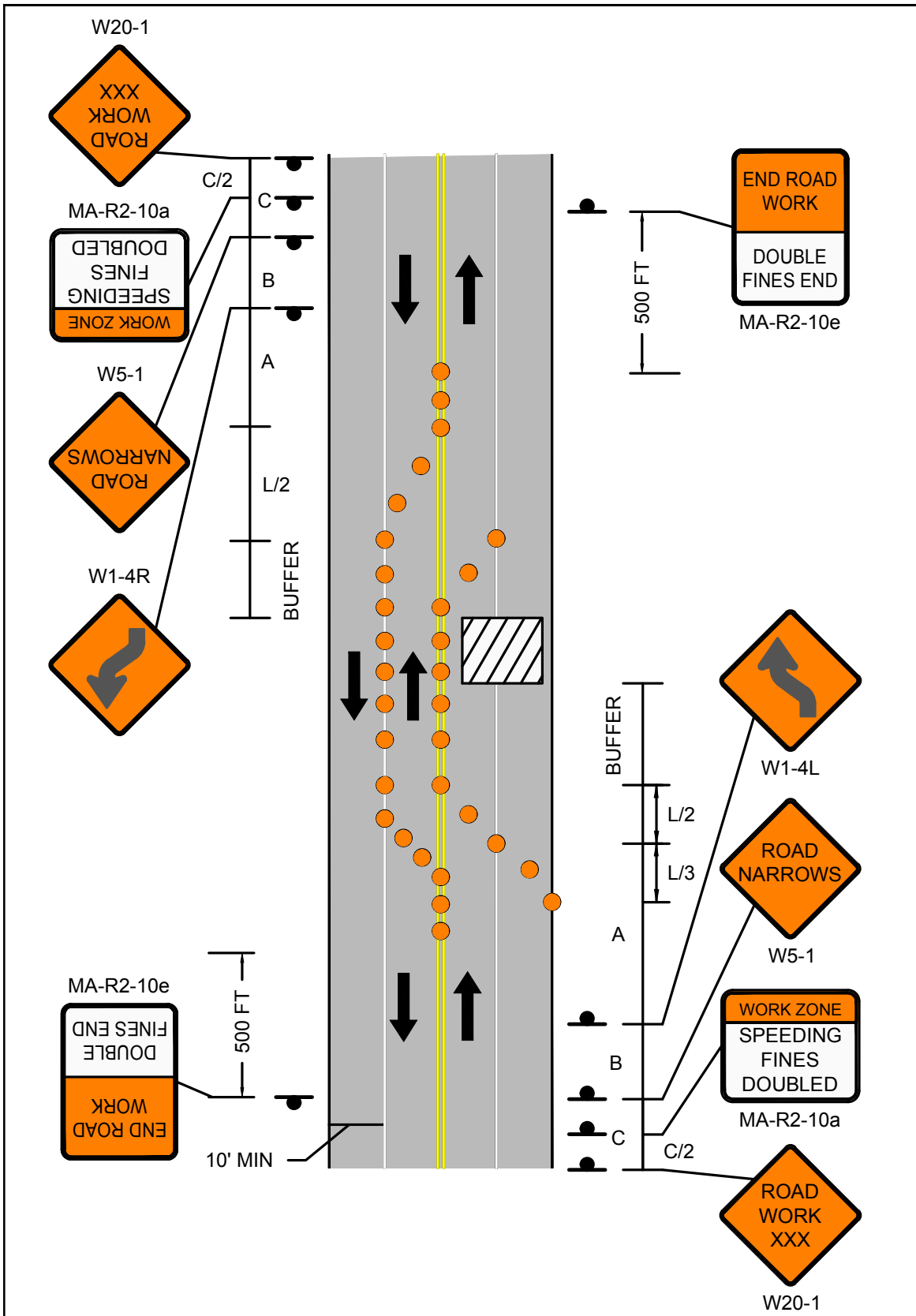

**FIGURE 9**  
 STATIONARY OPERATIONS  
 TWO LANE UNDIVIDED ROADWAY  
 WITH TRAVERSABLE SHOULDER  
 HALF OF ROADWAY CLOSED  
 MAINTAIN TWO-WAY TRAFFIC





PAGE 26

Work Zone Safety  
Standard Details  
and Drawings

STATIONARY OPERATIONS  
FOUR LANE UNDIVIDED ROADWAY  
RIGHT LANE CLOSED

POSTED SPEED LIMIT (MPH)	CHANNELATION DEVICES (DRUMS OR CONES)				
	SHOULDER TAPER LENGTH (L/3) (FT)	TRAVEL LANE CLOSURE LENGTH (L) (FT)	BUFFER ZONE LENGTH (FT)	DEVICE SPACING (FT)	MIN # OF DEVICES*
25-40	110	320	305	20	60
45-55	220	660	495	40	50
60-65	260	780	645	40	55









\* NUMBER OF DEVICES BASED ON 400 FT WORK ZONE.

POSTED SPEED LIMIT (MPH)	SPACING FOR ADVANCE WARNING SIGNS (FT) (A,B,C)
25-40	500 / 500 / 500
45-55	500 / 1000 / 1000
60-65	1000 / 1600 / 2600

**NOTES**

1. MA-R2-10a LOCATED AT A/2 AND C/2.
2. \*\*OPTIONAL AT THE ENGINEER'S DISCRETION.

**LEGEND**

-  WORK ZONE
-  CHANNELIZATION DEVICE
-  FLASHING ARROW BOARD
-  PORTABLE CHANGEABLE MESSAGE SIGN
-  TRUCK MOUNTED ATTENUATOR
-  RADAR SPEED FEEDBACK BOARD
-  POLICE DETAIL OR UNIFORMED FLAGGER
-  TEMPORARY PORTABLE RUMBLE STRIP
-  TYPE III BARRICADE

NOT TO SCALE

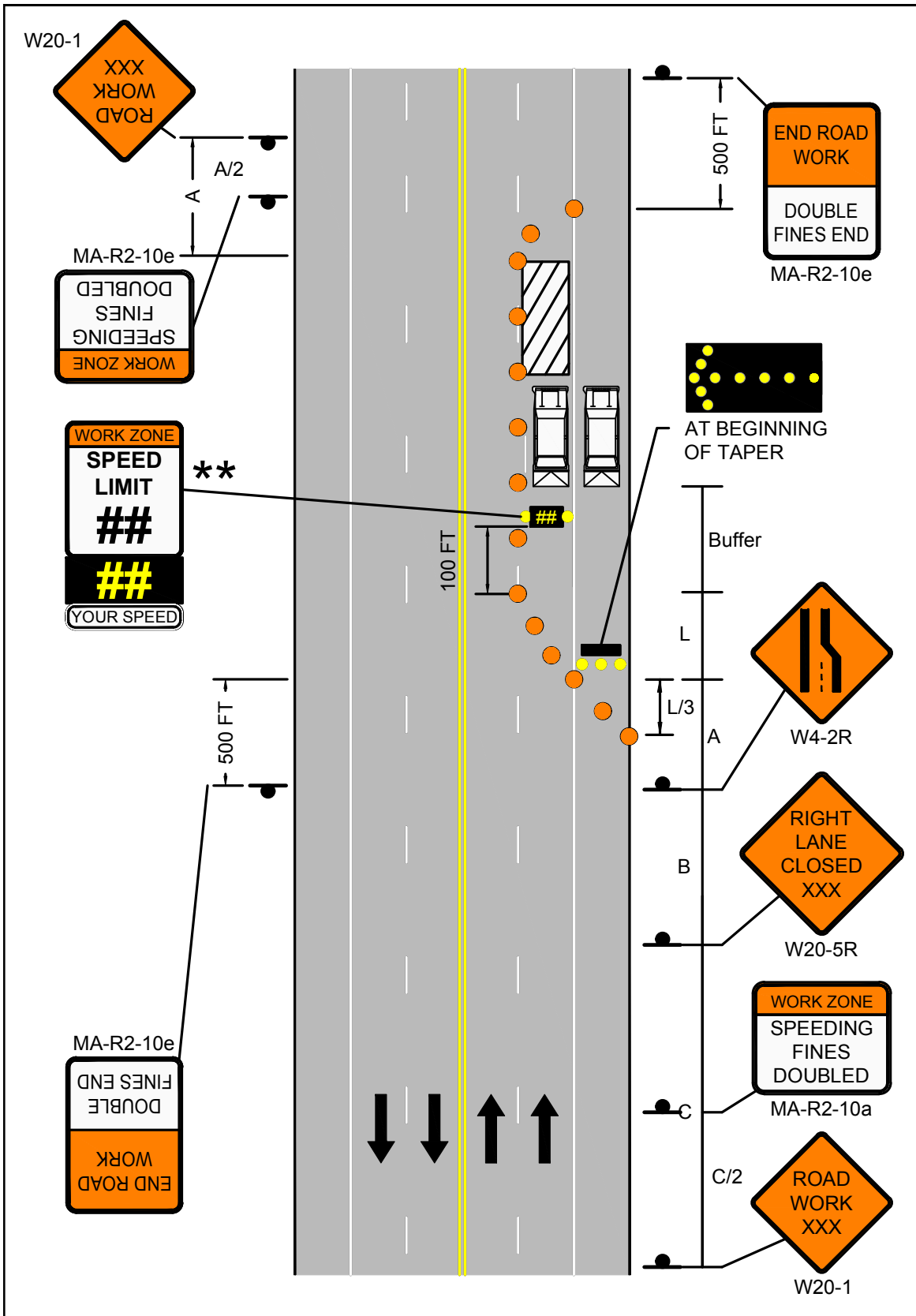

 <p>PAGE 27</p>	<p>Work Zone Safety Standard Details and Drawings</p>	<p>FIGURE 10 STATIONARY OPERATIONS FOUR LANE UNDIVIDED ROADWAY RIGHT LANE CLOSED</p>
--	---	--



PAGE 28

Work Zone Safety  
Standard Details  
and Drawings

STATIONARY OPERATIONS  
FOUR LANE UNDIVIDED ROADWAY  
LEFT LANE CLOSED









POSTED SPEED LIMIT (MPH)	SPACING FOR ADVANCE WARNING SIGNS (FT) (A,B,C)	CHANNELIZATION DEVICES (DRUMS OR CONES)			
		TRAVEL LANE CLOSURE LENGTH (L) (FT)	BUFFER ZONE LENGTH (FT)	DEVICE SPACING (FT)	MIN # OF DEVICES*
25-40	500 / 500 / 500	320	305	20	105
45-55	500 / 1000 / 1000	660	495	40	80
60-65	1000 / 1600 / 2600	780	645	40	100

\* NUMBER OF DEVICES BASED ON 400 FT WORK ZONE.

**NOTES**

1. MA-R2-10a LOCATED AT A/2 AND C/2.
2. \*\*OPTIONAL AT THE ENGINEER'S DISCRETION. 2' OFFSET FROM EDGE OF TRAVEL LANE TO RADAR SPEED FEEDBACK BOARD IS REQUIRED. BOARD MAY BE MOVED FULLY OR PARTIALLY OFF PAVED SHOULDER, IF REQUIRED.

**LEGEND**

-  WORK ZONE
-  CHANNELIZATION DEVICE
-  FLASHING ARROW BOARD
-  PORTABLE CHANGEABLE MESSAGE SIGN
-  TRUCK MOUNTED ATTENUATOR
-  RADAR SPEED FEEDBACK BOARD
-  POLICE DETAIL OR UNIFORMED FLAGGER
-  TEMPORARY PORTABLE RUMBLE STRIP
-  TYPE III BARRICADE

NOT TO SCALE

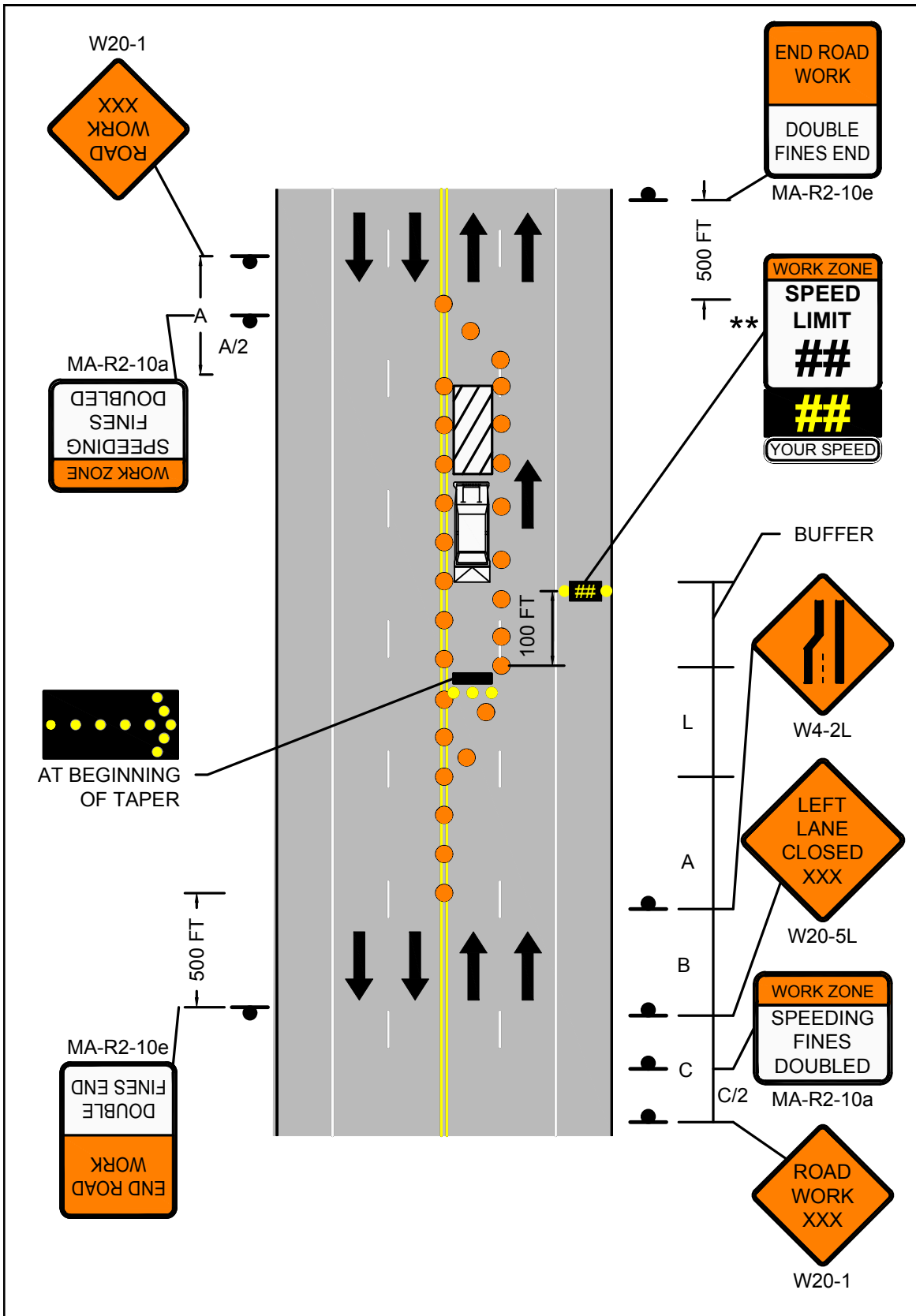

 <p>PAGE 29</p>	<p>Work Zone Safety Standard Details and Drawings</p>	<p>FIGURE 11 STATIONARY OPERATIONS FOUR LANE UNDIVIDED ROADWAY LEFT LANE CLOSED</p>
--	---	---

 <p>PAGE 30</p>	Work Zone Safety Standard Details and Drawings	STATIONARY OPERATIONS FOUR LANE UNDIVIDED ROADWAY HALF OF ROADWAY CLOSED
--	--	--

POSTED SPEED LIMIT (MPH)	CHANNELIZATION DEVICES (DRUMS OR CONES)					
	SHOULDER TAPER LENGTH (L/3) (FT)	TRAVEL LANE CLOSURE LENGTH (L) (FT)	TRAVEL LANE SHIFT LENGTH (L/2) (FT)	BUFFER ZONE LENGTH (FT)	DEVICE SPACING (FT)	MIN # OF DEVICES*
25-40	110	320	160	305	20	140
45-55	220	660	330	495	40	120
60-65	260	780	390	645	40	140









\* NUMBER OF DEVICES BASED ON 400 FT WORK ZONE.

POSTED SPEED LIMIT (MPH)	SPACING FOR ADVANCE WARNING SIGNS (FT) (A,B,C)
25-40	500 / 500 / 500
45-55	500 / 1000 / 1000
60-65	1000 / 1600 / 2600

**NOTES**

1. MA-R2-10a LOCATED AT C/2.
2. \*\*OPTIONAL AT THE ENGINEER'S DISCRETION.
3. W1-4L SHALL BE PLACED AT THE MIDDLE OF THE TANGENT.

**LEGEND**

-  WORK ZONE
-  CHANNELIZATION DEVICE
-  FLASHING ARROW BOARD
-  PORTABLE CHANGEABLE MESSAGE SIGN
-  TRUCK MOUNTED ATTENUATOR
-  RADAR SPEED FEEDBACK BOARD
-  POLICE DETAIL OR UNIFORMED FLAGGER
-  TEMPORARY PORTABLE RUMBLE STRIP
-  TYPE III BARRICADE

NOT TO SCALE

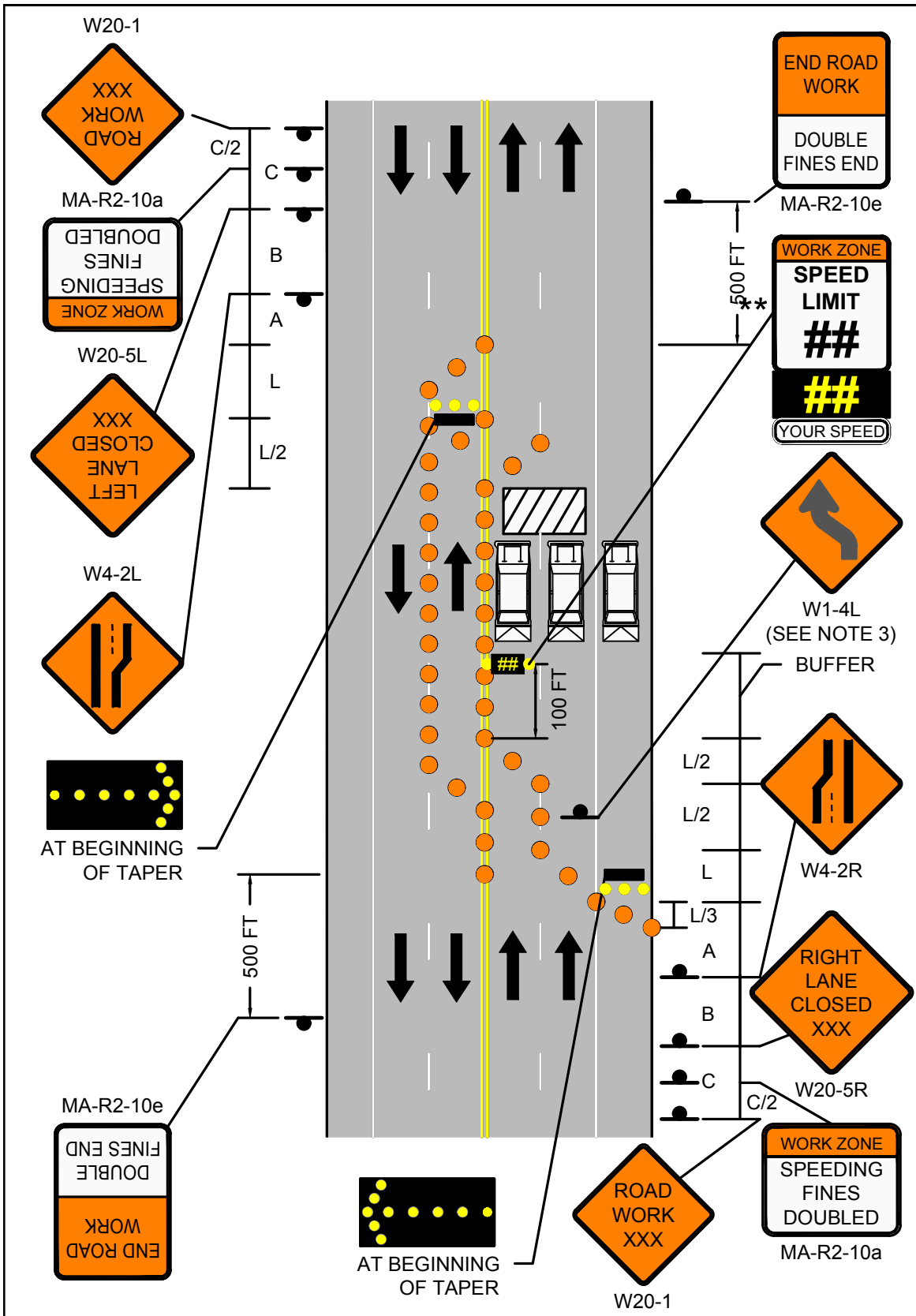

 <p>PAGE 31</p>	<p>Work Zone Safety Standard Details and Drawings</p>	<p>FIGURE 12 STATIONARY OPERATIONS FOUR LANE UNDIVIDED ROADWAY HALF OF ROADWAY CLOSED</p>
--	---	---



PAGE 32

Work Zone Safety  
Standard Details  
and Drawings

STATIONARY OPERATIONS  
MULTILANE DIVIDED ROADWAY  
RIGHT LANE CLOSED

POSTED SPEED LIMIT (MPH)	CHANNELIZATION DEVICES (DRUMS OR CONES)				
	SHOULDER TAPER LENGTH (L/3) (FT)	TRAVEL LANE CLOSURE LENGTH (L) (FT)	BUFFER ZONE LENGTH (FT)	DEVICE SPACING (FT)	MIN # OF DEVICES*
25-40	110	320	305	20	60
45-55	220	660	495	40	50
60-65	260	780	645	40	55









\* NUMBER OF DEVICES BASED ON 400 FT WORK ZONE.

POSTED SPEED LIMIT (MPH)	SPACING FOR ADVANCE WARNING SIGNS (FT) (A,B,C)
25-40	500 / 500 / 500
45-55	500 / 1000 / 1000
60-65	1000 / 1600 / 2600

**NOTES**

1. MA-R2-10a LOCATED AT C/2.
2. \*\*OPTIONAL AT THE ENGINEER'S DISCRETION.

**LEGEND**

-  WORK ZONE
-  CHANNELIZATION DEVICE
-  FLASHING ARROW BOARD
-  PORTABLE CHANGEABLE MESSAGE SIGN
-  TRUCK MOUNTED ATTENUATOR
-  RADAR SPEED FEEDBACK BOARD
-  POLICE DETAIL OR UNIFORMED FLAGGER
-  TEMPORARY PORTABLE RUMBLE STRIP
-  TYPE III BARRICADE

NOT TO SCALE

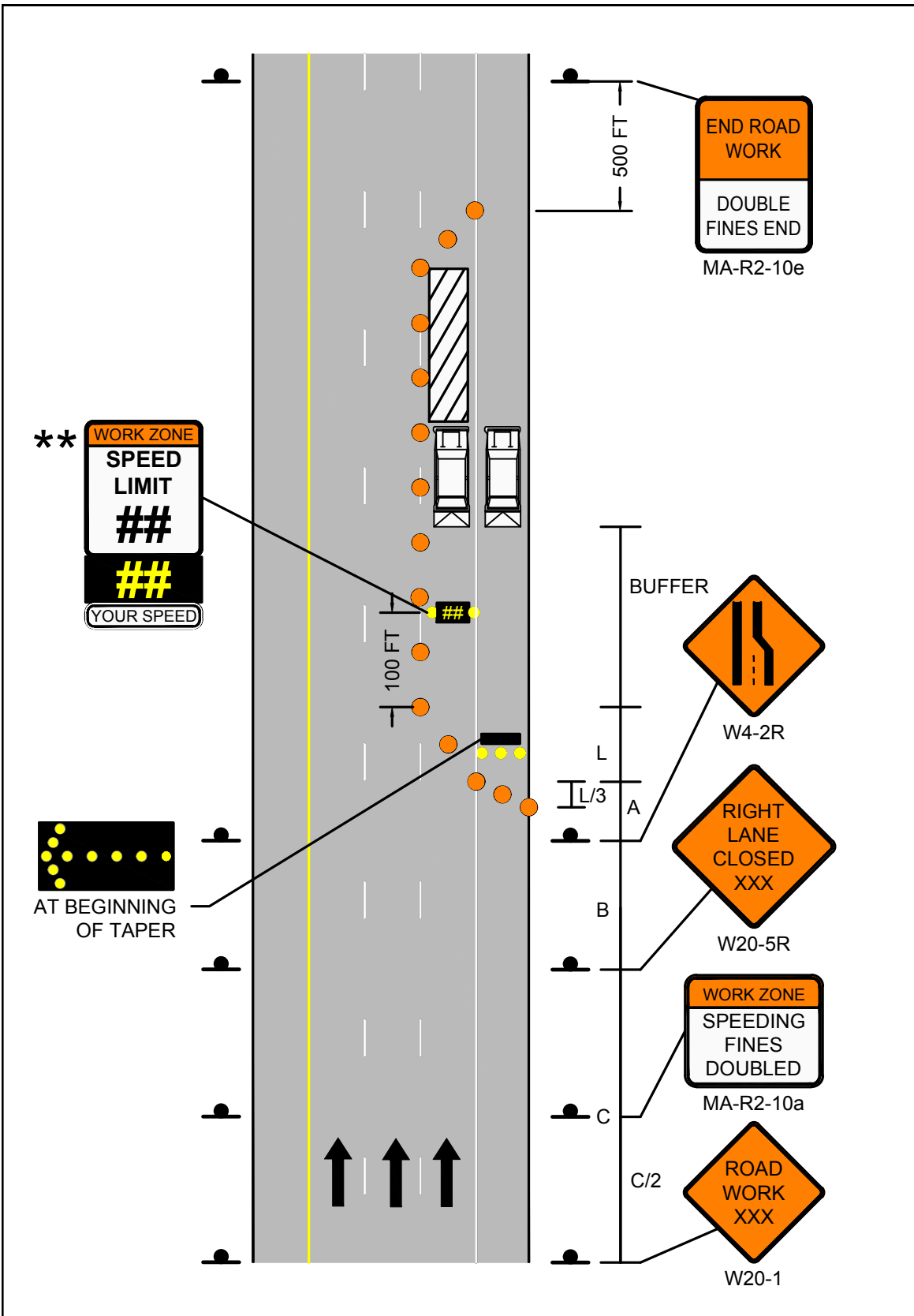

 <p>PAGE 33</p>	<p>Work Zone Safety Standard Details and Drawings</p>	<p>FIGURE 13 STATIONARY OPERATIONS MULTILANE DIVIDED ROADWAY RIGHT LANE CLOSED</p>
--	---	--



PAGE 34

Work Zone Safety  
Standard Details  
and Drawings

STATIONARY OPERATIONS  
MULTILANE DIVIDED ROADWAY  
LEFT LANE CLOSED

POSTED SPEED LIMIT (MPH)	CHANNELIZATION DEVICES (DRUMS OR CONES)				
	SHOULDER TAPER LENGTH (L/3) (FT)	TRAVEL LANE CLOSURE LENGTH (L) (FT)	BUFFER ZONE LENGTH (FT)	DEVICE SPACING (FT)	MIN # OF DEVICES*
25-40	110	320	305	20	60
45-55	220	660	495	40	50
60-65	260	780	645	40	55









\* NUMBER OF DEVICES BASED ON 400 FT WORK ZONE.

POSTED SPEED LIMIT (MPH)	SPACING FOR ADVANCE WARNING SIGNS (FT) (A,B,C)
25-40	500 / 500 / 500
45-55	500 / 1000 / 1000
60-65	1000 / 1600 / 2600

**NOTES**

1. MA-R2-10a LOCATED AT C/2.
2. \*\*OPTIONAL AT THE ENGINEER'S DISCRETION.

**LEGEND**

-  WORK ZONE
-  CHANNELIZATION DEVICE
-  FLASHING ARROW BOARD
-  PORTABLE CHANGEABLE MESSAGE SIGN
-  TRUCK MOUNTED ATTENUATOR
-  RADAR SPEED FEEDBACK BOARD
-  POLICE DETAIL OR UNIFORMED FLAGGER
-  TEMPORARY PORTABLE RUMBLE STRIP
-  TYPE III BARRICADE

NOT TO SCALE

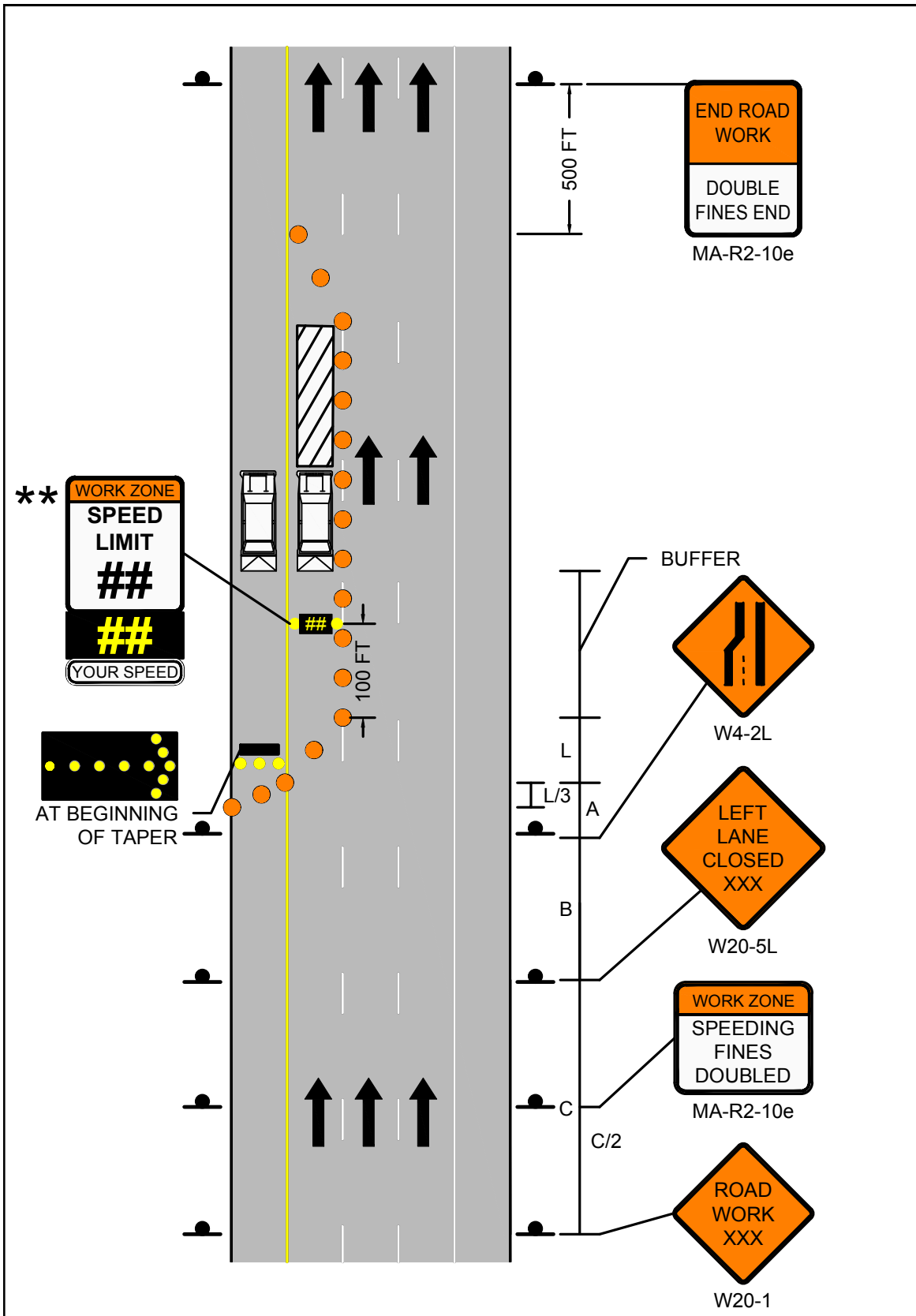

 <p>Massachusetts Department of Transportation Highway Division</p> <p>PAGE 36</p>	<p>Work Zone Safety Standard Details and Drawings</p>	<p>STATIONARY OPERATIONS MULTILANE DIVIDED ROADWAY CENTER LANE OR RIGHT/CENTER LANES CLOSED</p>
---	---	---

POSTED SPEED LIMIT (MPH)	CHANNELIZATION DEVICES (DRUMS OR CONES)					
	SHOULDER TAPER LENGTH (L/3) (FT)	TRAVEL LANE CLOSURE LENGTH (L) (FT)	TANGENT LENGTH BETWEEN TAPERS T (FT)	BUFFER ZONE LENGTH (FT)	DEVICE SPACING (FT)	MIN # OF DEVICES*
25-40	110	320	640	305	20	110
45-55	220	660	1320	495	40	100
60-65	260	780	1560	645	40	115









\* NUMBER OF DEVICES BASED ON 400 FT WORK ZONE.

POSTED SPEED LIMIT (MPH)	SPACING FOR ADVANCE WARNING SIGNS (FT) (A,B,C)
25-40	500 / 500 / 500
45-55	500 / 1000 / 1000
60-65	1000 / 1600 / 2600

**NOTES**

1. MA-R2-10a LOCATED AT C/2.
2. \*\*\*OPTIONAL AT THE ENGINEER'S DISCRETION.
3. \*\*\*THIS SET OF SIGNS SHALL BE LOCATED AT T/2.

**LEGEND**

-  WORK ZONE
-  CHANNELIZATION DEVICE
-  FLASHING ARROW BOARD
-  PORTABLE CHANGEABLE MESSAGE SIGN
-  TRUCK MOUNTED ATTENUATOR
-  RADAR SPEED FEEDBACK BOARD
-  POLICE DETAIL OR UNIFORMED FLAGGER
-  TEMPORARY PORTABLE RUMBLE STRIP
-  TYPE III BARRICADE

NOT TO SCALE

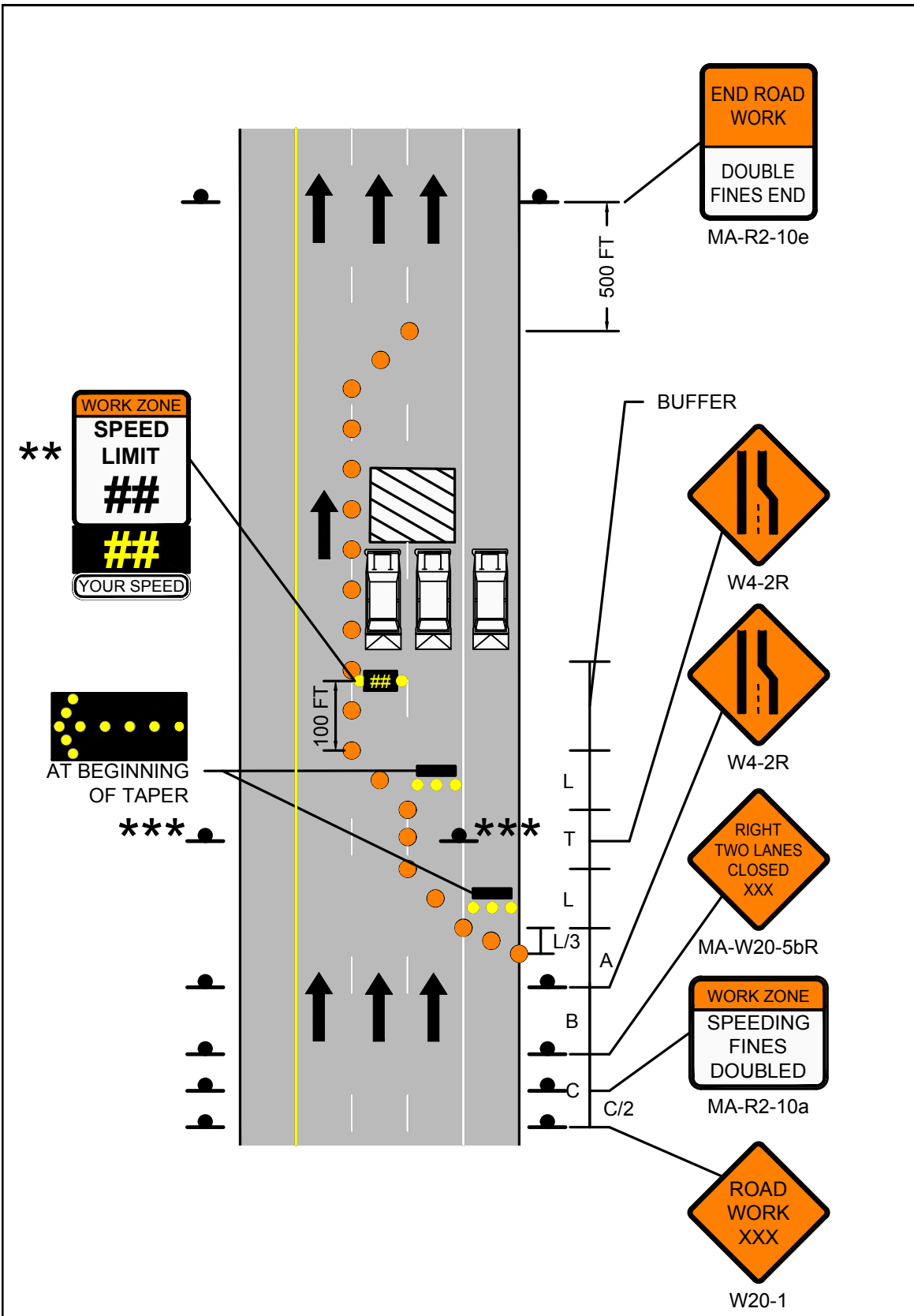

 <p>PAGE 37</p>	<p>Work Zone Safety Standard Details and Drawings</p>	<p>FIGURE 15 STATIONARY OPERATIONS MULTILANE DIVIDED ROADWAY CENTER LANE OR RIGHT/CENTER LANES CLOSED</p>
--	---	---

 <p>Massachusetts Department of Transportation Highway Division</p> <p>PAGE 38</p>	Work Zone Safety Standard Details and Drawings	STATIONARY OPERATIONS MULTILANE DIVIDED ROADWAY CENTER LANE OR LEFT/CENTER LANES CLOSED
---	--	--

POSTED SPEED LIMIT (MPH)	CHANNELIZATION DEVICES (DRUMS OR CONES)					
	SHOULDER TAPER LENGTH (L/3) (FT)	TRAVEL LANE CLOSURE LENGTH (L) (FT)	TANGENT LENGTH BETWEEN TAPERS T (FT)	BUFFER ZONE LENGTH (FT)	DEVICE SPACING (FT)	MIN # OF DEVICES*
25-40	110	320	640	305	20	110
45-55	220	660	1320	495	40	100
60-65	260	780	1560	645	40	115









\* NUMBER OF DEVICES BASED ON 400 FT WORK ZONE.

POSTED SPEED LIMIT (MPH)	SPACING FOR ADVANCE WARNING SIGNS (FT) (A,B,C)
25-40	500 / 500 / 500
45-55	500 / 1000 / 1000
60-65	1000 / 1600 / 2600

**NOTES**

1. MA-R2-10a LOCATED AT C/2.
2. \*\*\*OPTIONAL AT THE ENGINEER'S DISCRETION.
3. \*\*\*THIS SET OF SIGNS SHALL BE LOCATED AT T/2.

**LEGEND**

-  WORK ZONE
-  CHANNELIZATION DEVICE
-  FLASHING ARROW BOARD
-  PORTABLE CHANGEABLE MESSAGE SIGN
-  TRUCK MOUNTED ATTENUATOR
-  RADAR SPEED FEEDBACK BOARD
-  POLICE DETAIL OR UNIFORMED FLAGGER
-  TEMPORARY PORTABLE RUMBLE STRIP
-  TYPE III BARRICADE

NOT TO SCALE

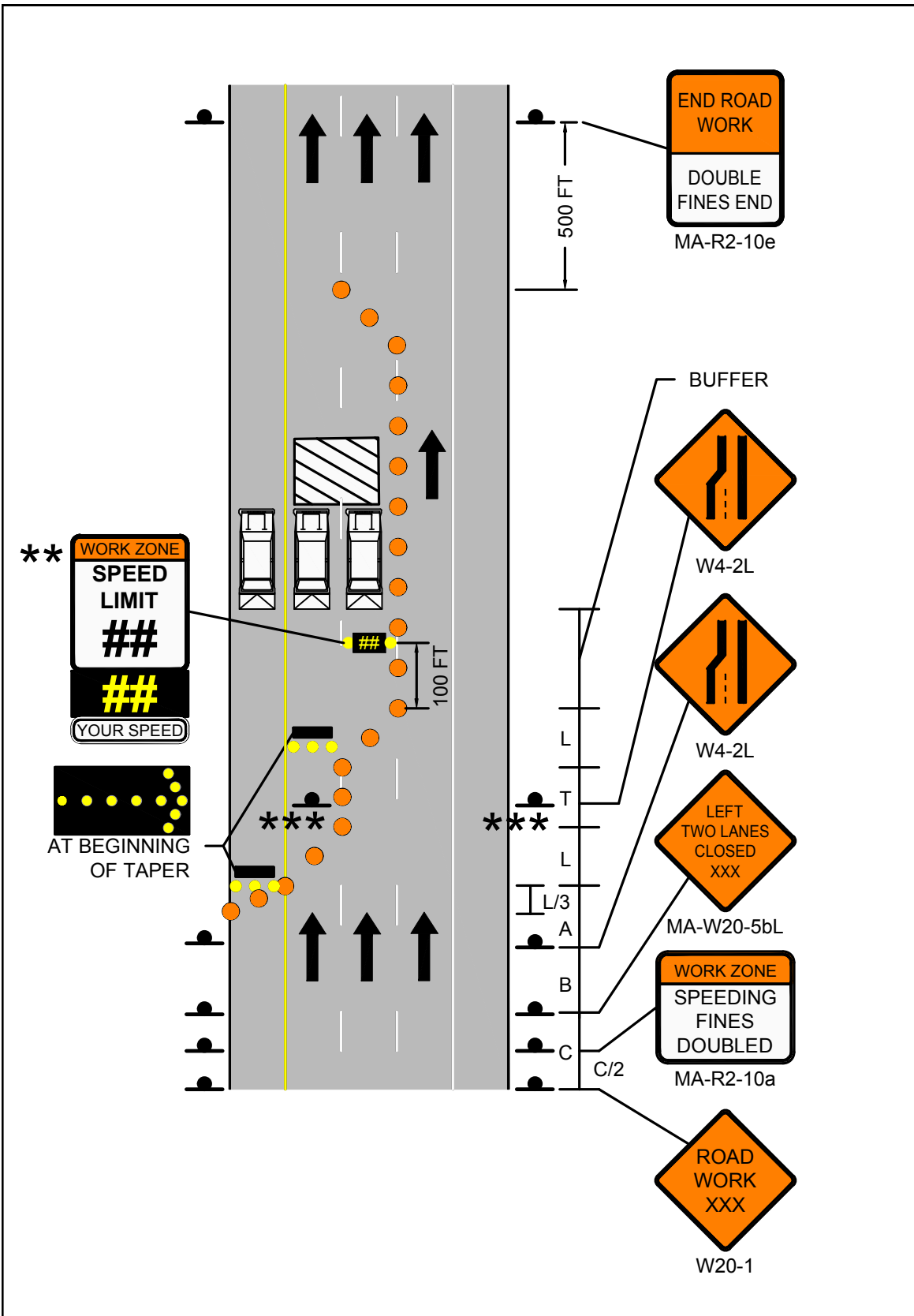

 <p>PAGE 39</p>	<p>Work Zone Safety Standard Details and Drawings</p>	<p>FIGURE 16 STATIONARY OPERATIONS MULTILANE DIVIDED ROADWAY CENTER LANE OR LEFT/CENTER LANES CLOSED</p>
--	---	--



PAGE 40

Work Zone Safety  
Standard Details  
and Drawings

STATIONARY OPERATIONS  
MULTILANE DIVIDED ROADWAY  
RIGHT SIDE OF OFF RAMP CLOSED









POSTED SPEED LIMIT (MPH)	SPACING FOR ADVANCE WARNING SIGNS (FT) (A,B,C)	CHANNELIZATION DEVICES (DRUMS OR CONES)			
		TRAVEL LANE SHIFT LENGTH (L/2) (FT)	BUFFER ZONE LENGTH (FT)	DEVICE SPACING (FT)	MIN # OF DEVICES*
25-40	500 / 500 / 500	160	305	20	45
45-55	500 / 1000 / 1000	330	495	40	35

\* NUMBER OF DEVICES BASED ON 400 FT WORK ZONE.

NOTES

1. MA-R2-10a LOCATED AT C/2.

LEGEND

-  WORK ZONE
-  CHANNELIZATION DEVICE
-  FLASHING ARROW BOARD
-  PORTABLE CHANGEABLE MESSAGE SIGN
-  TRUCK MOUNTED ATTENUATOR
-  RADAR SPEED FEEDBACK BOARD
-  POLICE DETAIL OR UNIFORMED FLAGGER
-  TEMPORARY PORTABLE RUMBLE STRIP
-  TYPE III BARRICADE

NOT TO SCALE

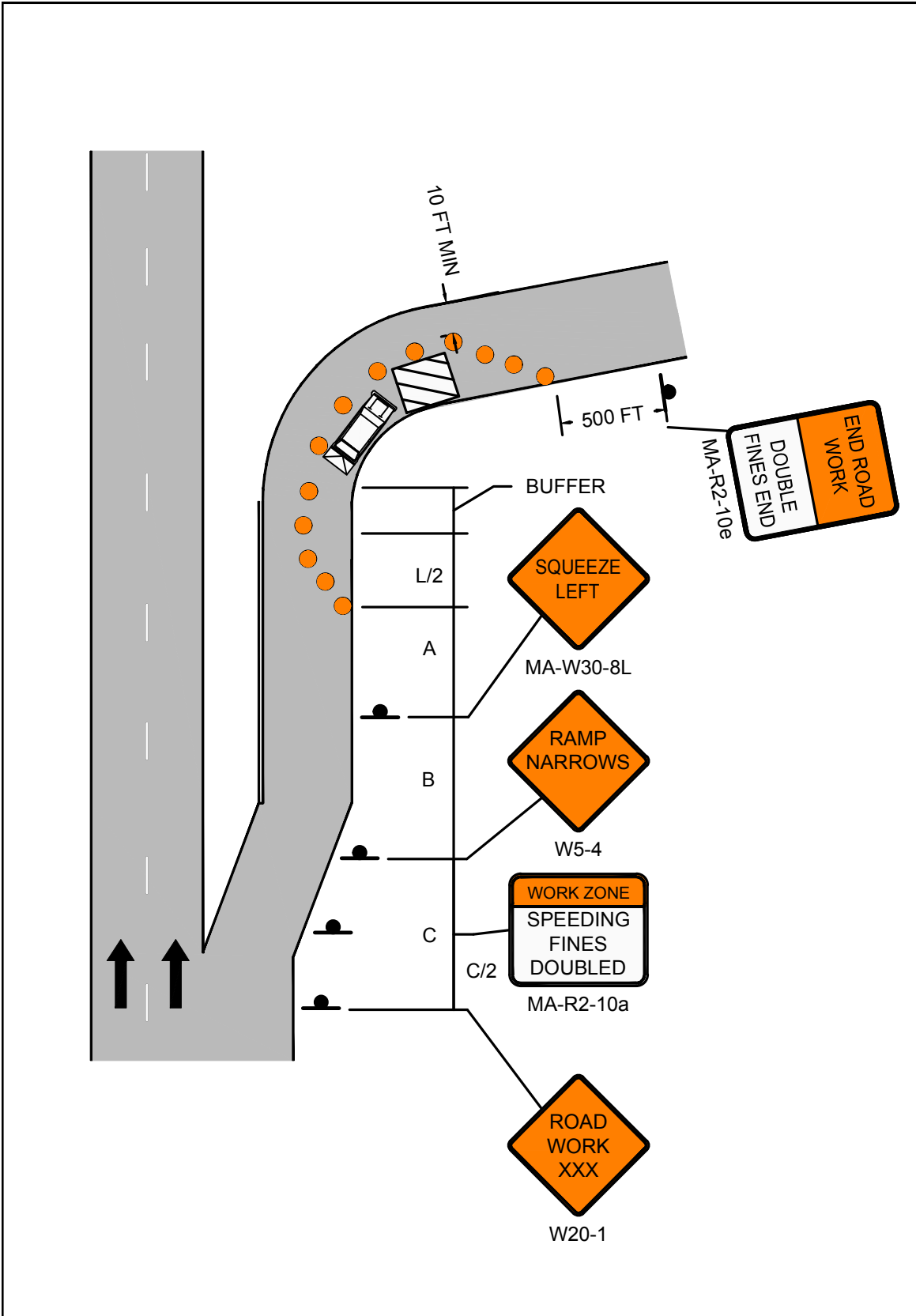

 <p>PAGE 41</p>	<p>Work Zone Safety Standard Details and Drawings</p>	<p>FIGURE 17 STATIONARY OPERATIONS MULTILANE DIVIDED ROADWAY RIGHT SIDE OF OFF RAMP CLOSED</p>
--	---	--



PAGE 42

Work Zone Safety  
Standard Details  
and Drawings

STATIONARY OPERATIONS  
MULTILANE DIVIDED ROADWAY  
LEFT SIDE OF OFF RAMP CLOSED









POSTED SPEED LIMIT (MPH)	SPACING FOR ADVANCE WARNING SIGNS (FT) (A,B,C)	CHANNELIZATION DEVICES (DRUMS OR CONES)			
		TRAVEL LANE SHIFT LENGTH (L/2) (FT)	BUFFER ZONE LENGTH (FT)	DEVICE SPACING (FT)	MIN # OF DEVICES*
25-40	500 / 500 / 500	160	305	20	45
45-55	500 / 1000 / 1000	330	495	40	35

\* NUMBER OF DEVICES BASED ON 400 FT WORK ZONE.

NOTES

1. MA-R2-10a LOCATED AT C/2.

LEGEND

-  WORK ZONE
-  CHANNELIZATION DEVICE
-  FLASHING ARROW BOARD
-  PORTABLE CHANGEABLE MESSAGE SIGN
-  TRUCK MOUNTED ATTENUATOR
-  RADAR SPEED FEEDBACK BOARD
-  POLICE DETAIL OR UNIFORMED FLAGGER
-  TEMPORARY PORTABLE RUMBLE STRIP
-  TYPE III BARRICADE

NOT TO SCALE

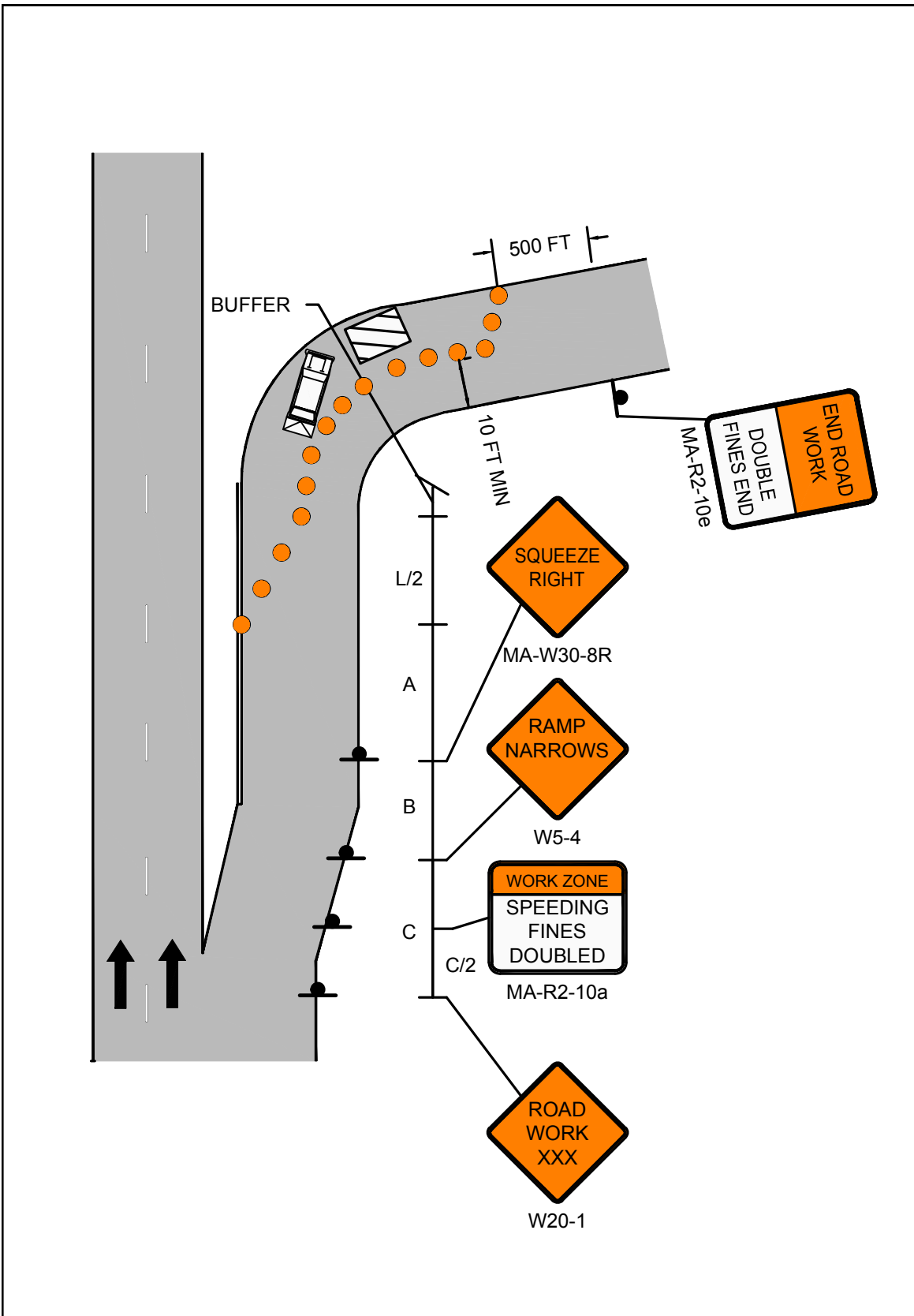

	<p>Work Zone Safety Standard Details and Drawings</p>	<p>FIGURE 18 STATIONARY OPERATIONS MULTILANE DIVIDED ROADWAY LEFT SIDE OF OFF RAMP CLOSED PAGE 43</p>
---	---	---



PAGE 44

Work Zone Safety  
Standard Details  
and Drawings

STATIONARY OPERATIONS  
MULTILANE DIVIDED ROADWAY  
ROADWORK BEYOND ON RAMP

POSTED SPEED LIMIT (MPH)	CHANNELIZATION DEVICES (DRUMS OR CONES)				
	SHOULDER TAPER LENGTH (L/3) (FT)	TRAVEL LANE CLOSURE LENGTH (L) (FT)	BUFFER ZONE LENGTH (FT)	DEVICE SPACING (FT)	MIN # OF DEVICES*
25-40	110	320	305	20	175
45-55	220	660	495	40	135
60-65	260	780	645	40	155









\* NUMBER OF DEVICES BASED ON 400 FT WORK ZONE.

POSTED SPEED LIMIT (MPH)	SPACING FOR ADVANCE WARNING SIGNS (FT) (A,B,C)
25-40	500 / 500 / 500
45-55	500 / 1000 / 1000
60-65	1000 / 1600 / 2600

**NOTES**

1. MA-R2-10a LOCATED AT C/2.

**LEGEND**

-  WORK ZONE
-  CHANNELIZATION DEVICE
-  FLASHING ARROW BOARD
-  PORTABLE CHANGEABLE MESSAGE SIGN
-  TRUCK MOUNTED ATTENUATOR
-  RADAR SPEED FEEDBACK BOARD
-  POLICE DETAIL OR UNIFORMED FLAGGER
-  TEMPORARY PORTABLE RUMBLE STRIP
-  TYPE III BARRICADE

NOT TO SCALE

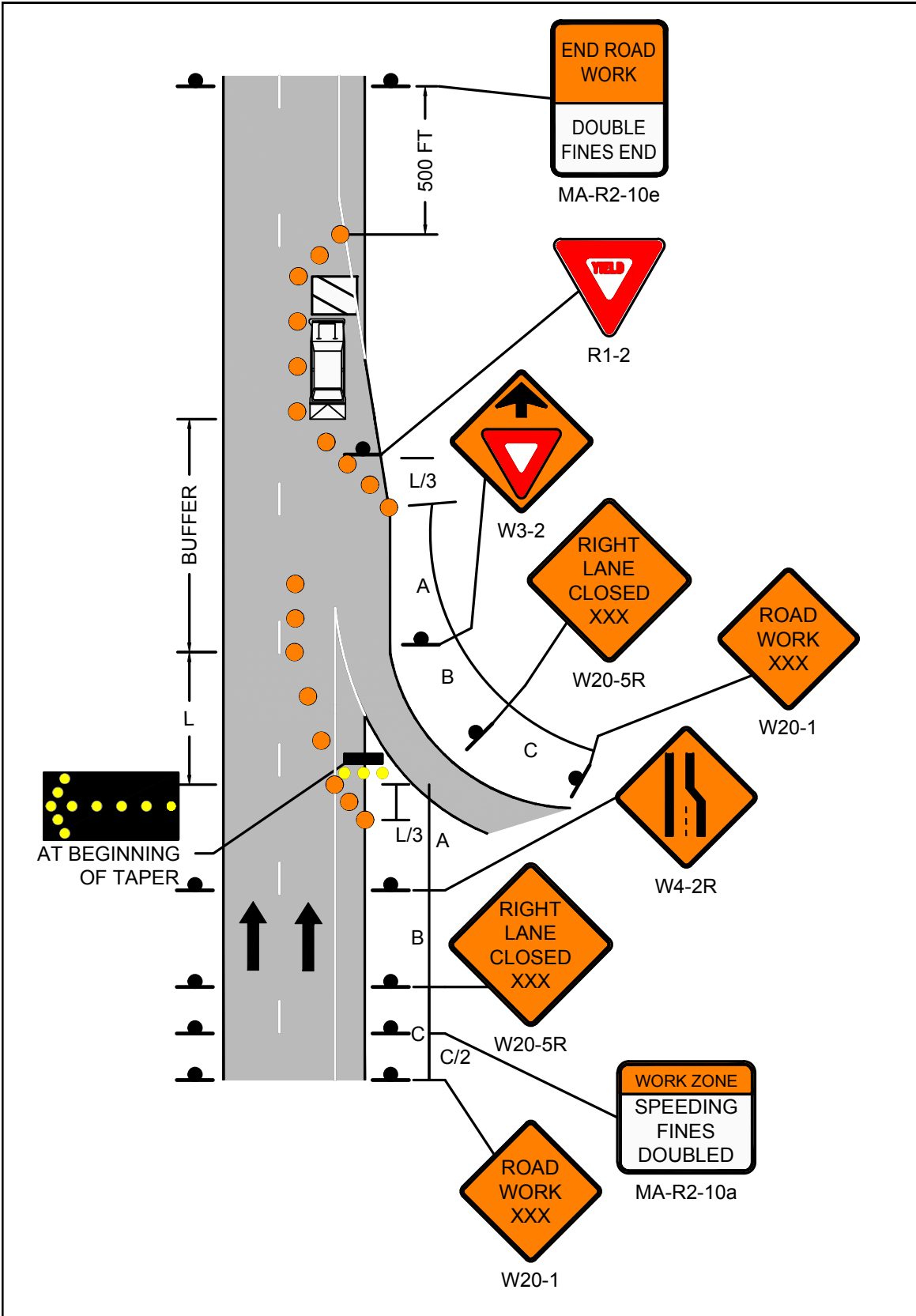

 <p>PAGE 45</p>	<p>Work Zone Safety Standard Details and Drawings</p>	<p>FIGURE 19 STATIONARY OPERATIONS MULTILANE DIVIDED ROADWAY ROADWORK BEYOND ON RAMP</p>
--	---	--

 <p>Massachusetts Department of Transportation Highway Division</p> <p>PAGE 46</p>	<p>Work Zone Safety Standard Details and Drawings</p>	<p>STATIONARY OPERATIONS MULTILANE DIVIDED ROADWAY ROADWORK BEYOND OFF RAMP</p>
---	---	---

POSTED SPEED LIMIT (MPH)	CHANNELIZATION DEVICES (DRUMS OR CONES)					
	SHOULDER TAPER LENGTH (L/3) (FT)	TRAVEL LANE CLOSURE LENGTH (L) (FT)	TRAVEL LANE SHIFT LENGTH (L/2) (FT)	BUFFER ZONE LENGTH (FT)	DEVICE SPACING (FT)	MIN # OF DEVICES*
25-40	110	320	160	305	20	70
45-55	220	660	330	495	40	55
60-65	260	780	390	645	40	65









\* NUMBER OF DEVICES BASED ON 400 FT WORK ZONE.

POSTED SPEED LIMIT (MPH)	SPACING FOR ADVANCE WARNING SIGNS (FT) (A,B,C)
25-40	500 / 500 / 500
45-55	500 / 1000 / 1000
60-65	1000 / 1600 / 2600

**NOTES**

1. MA-R2-10a LOCATED AT C/2.

**LEGEND**

-  WORK ZONE
-  CHANNELIZATION DEVICE
-  FLASHING ARROW BOARD
-  PORTABLE CHANGEABLE MESSAGE SIGN
-  TRUCK MOUNTED ATTENUATOR
-  RADAR SPEED FEEDBACK BOARD
-  POLICE DETAIL OR UNIFORMED FLAGGER
-  TEMPORARY PORTABLE RUMBLE STRIP
-  TYPE III BARRICADE

NOT TO SCALE

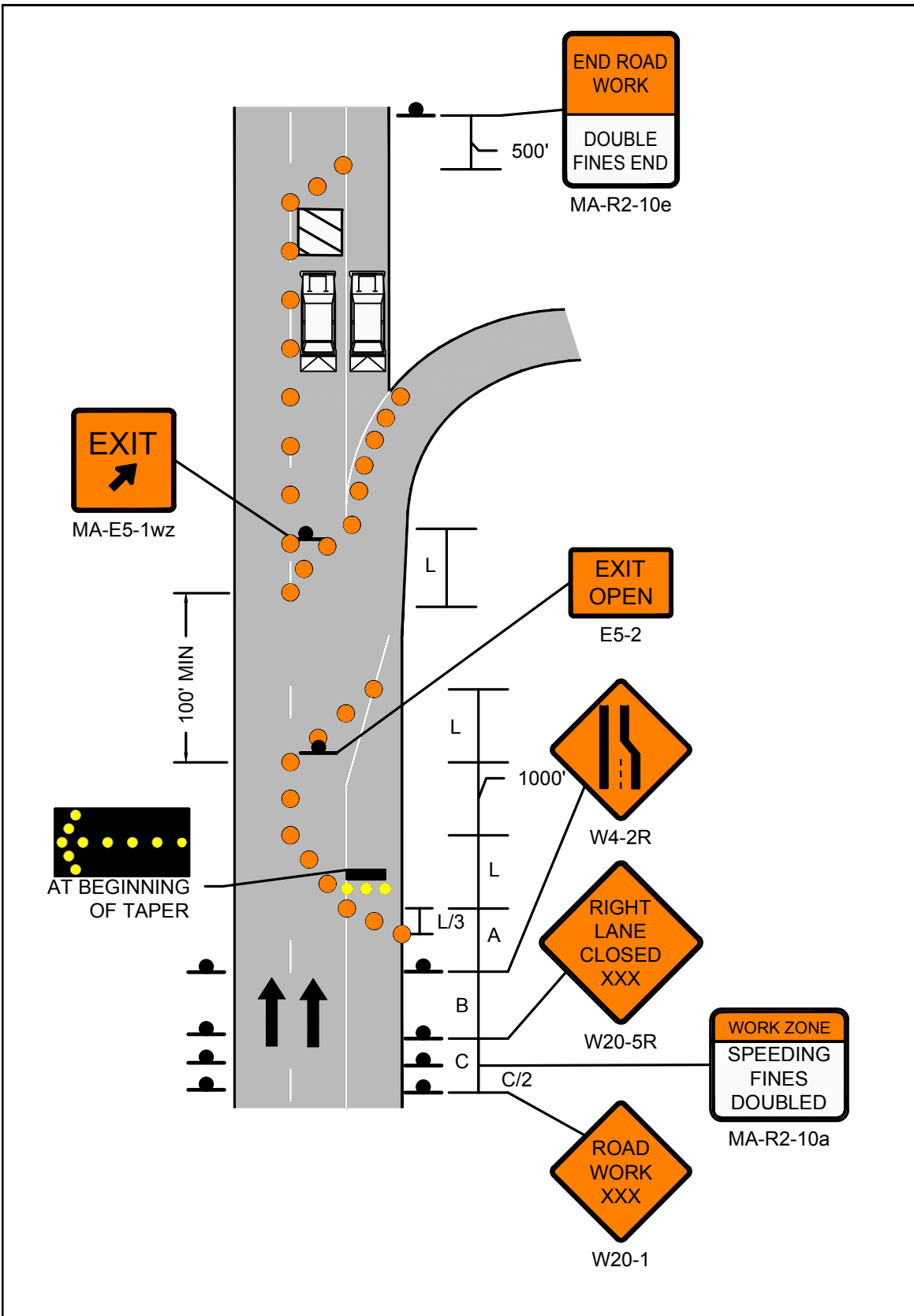

 <p>PAGE 47</p>	<p>Work Zone Safety Standard Details and Drawings</p>	<p>FIGURE 20 STATIONARY OPERATIONS MULTILANE DIVIDED ROADWAY ROADWORK BEYOND OFF RAMP</p>
--	---	---



PAGE 48

Work Zone Safety  
Standard Details  
and Drawings









MULTILANE DIVIDED ROADWAY  
TYPICAL RAMP CLOSURE

POSTED SPEED LIMIT (MPH)	SPACING FOR ADVANCE WARNING SIGNS (FT) (A,B,C)	CHANNELIZATION DEVICES (DRUMS OR CONES)			
		SHOULDER TAPER LENGTH (L/3) (FT)	BUFFER ZONE LENGTH (FT)	DEVICE SPACING (FT)	MIN # OF DEVICES
25-40	500 / 500 / 500	110	305	20	45
45-55	500 / 1000 / 1000	220	495	40	30
60-65	1000 / 1600 / 2600	260	645	40	35

NOTES

1. MA-R2-10a LOCATED AT C/2.
2. \* NOT REQUIRED IF RIGHT LANE IS CLOSED IN ADVANCE OF EXIT.
3. \*\* OPTIONAL AT ENGINEER'S DISCRETION.

LEGEND

-  WORK ZONE
-  CHANNELIZATION DEVICE
-  FLASHING ARROW BOARD
-  PORTABLE CHANGEABLE MESSAGE SIGN
-  TRUCK MOUNTED ATTENUATOR
-  RADAR SPEED FEEDBACK BOARD
-  POLICE DETAIL OR UNIFORMED FLAGGER
-  TEMPORARY PORTABLE RUMBLE STRIP
-  TYPE III BARRICADE

NOT TO SCALE

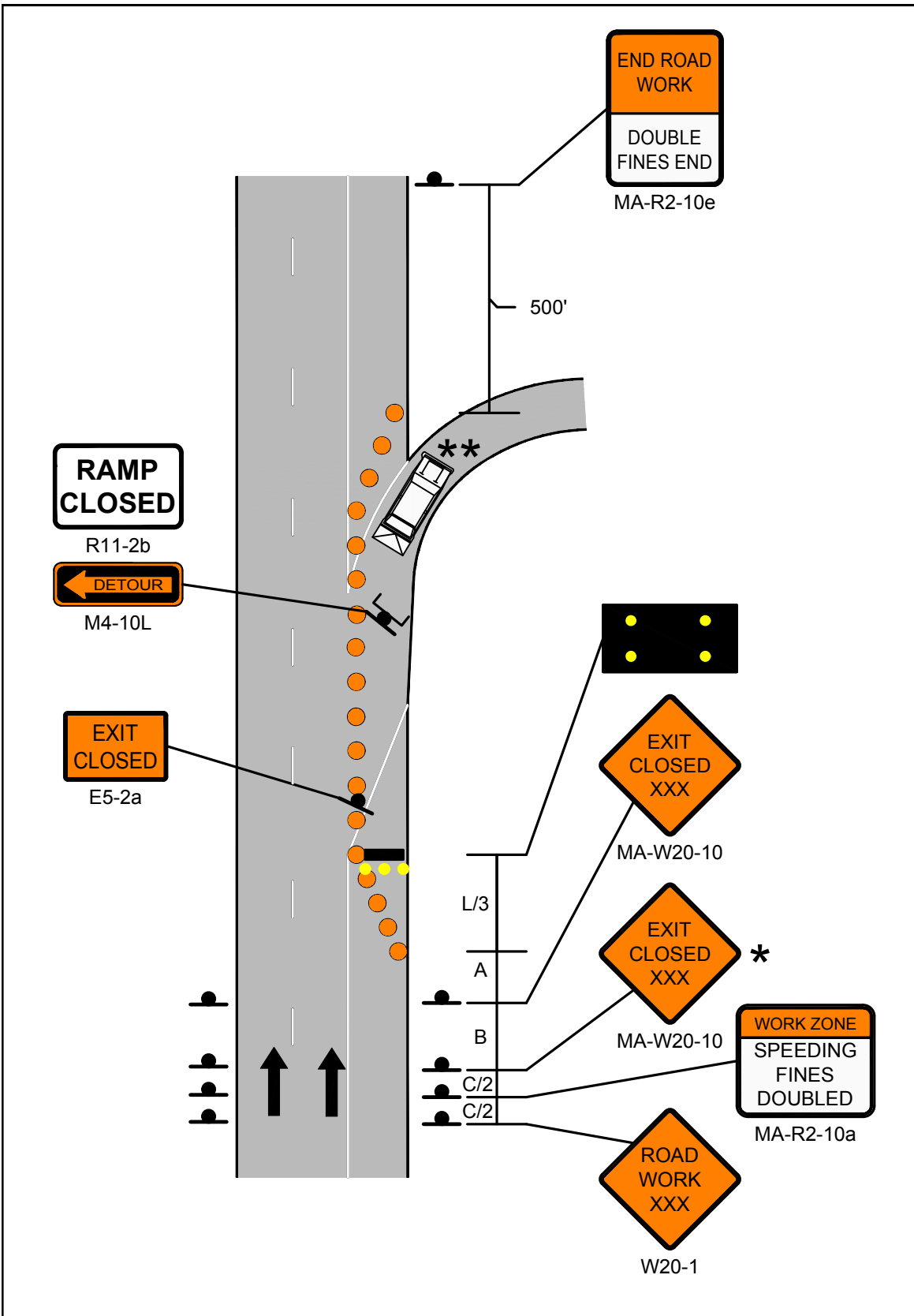



PAGE 50

Work Zone Safety  
Standard Details  
and Drawings









MULTILANE DIVIDED ROADWAY  
TYPICAL CLOVERLEAF RAMP CLOSURE

POSTED SPEED LIMIT (MPH)	SPACING FOR ADVANCE WARNING SIGNS (FT) (A,B,C)	CHANNELIZATION DEVICES (DRUMS OR CONES)			
		SHOULDER TAPER LENGTH (L/3) (FT)	BUFFER ZONE LENGTH (FT)	DEVICE SPACING (FT)	MIN # OF DEVICES
25-40	500 / 500 / 500	110	305	20	45
45-55	500 / 1000 / 1000	220	495	40	30
60-65	1000 / 1600 / 2600	260	645	40	35

**NOTES**

1. MA-R2-10a LOCATED AT C/2.
2. \* NOT REQUIRED IF RIGHT LANE IS CLOSED IN ADVANCE OF EXIT.
3. \*\* OPTIONAL AT ENGINEER'S DISCRETION.

**LEGEND**

-  WORK ZONE
-  CHANNELIZATION DEVICE
-  FLASHING ARROW BOARD
-  PORTABLE CHANGEABLE MESSAGE SIGN
-  TRUCK MOUNTED ATTENUATOR
-  RADAR SPEED FEEDBACK BOARD
-  POLICE DETAIL OR UNIFORMED FLAGGER
-  TEMPORARY PORTABLE RUMBLE STRIP
-  TYPE III BARRICADE

NOT TO SCALE

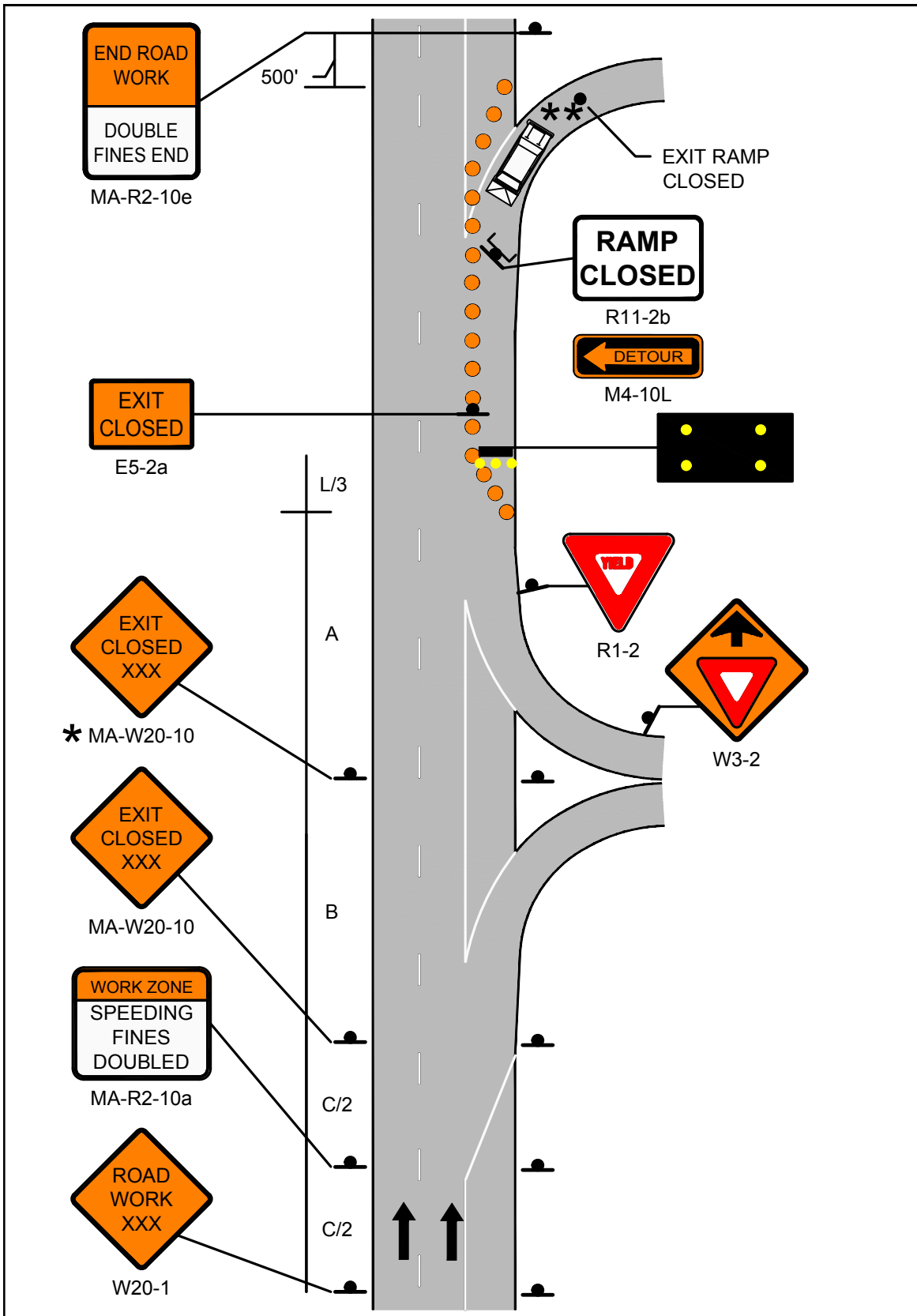

 <p>Massachusetts Department of Transportation Highway Division</p> <p>PAGE 51</p>	<p>Work Zone Safety Standard Details and Drawings</p>	<p>FIGURE 22 MULTILANE DIVIDED ROADWAY TYPICAL CLOVERLEAF RAMP CLOSURE</p>
---	---	--



PAGE 52









Work Zone Safety  
Standard Details  
and Drawings

MULTILANE DIVIDED ROADWAY  
TYPICAL RAMP CLOSURE  
ADVANCE SIGNING

NOTES

1. IF THE CLOSED RAMP IS LOCATED DOWNSTREAM FROM THE PROPOSED DETOUR ROUTE/RAMP, A PCMS SHALL BE POSITIONED AT A SUFFICIENT DISTANCE IN ADVANCE OF THE DETOUR ROUTE/RAMP AND SHOULD STATE WHICH RAMP IS CLOSED AND WHICH SHALL BE USED FOR THE DETOUR.
2. IF THE CLOSED RAMP IS LOCATED UPSTREAM FROM THE PROPOSED DETOUR ROUTE/RAMP, A PCMS SHALL BE POSITIONED PRIOR TO THE CLOSED RAMP AND SHOULD STATE WHICH RAMP IS CLOSED AND WHICH SHALL BE USED FOR THE DETOUR.
3. A SUFFICIENT NUMBER OF DETOUR SIGNS (M4-9 SERIES) SHOULD BE DEPLOYED TO PROPERLY DIRECT DETOURED TRAFFIC. SIGN SPACING SHALL BE AT THE DIRECTION OF THE ENGINEER.

LEGEND

-  WORK ZONE
-  CHANNELIZATION DEVICE
-  FLASHING ARROW BOARD
-  PORTABLE CHANGEABLE MESSAGE SIGN
-  TRUCK MOUNTED ATTENUATOR
-  RADAR SPEED FEEDBACK BOARD
-  POLICE DETAIL OR UNIFORMED FLAGGER
-  TEMPORARY PORTABLE RUMBLE STRIP
-  TYPE III BARRICADE

NOT TO SCALE

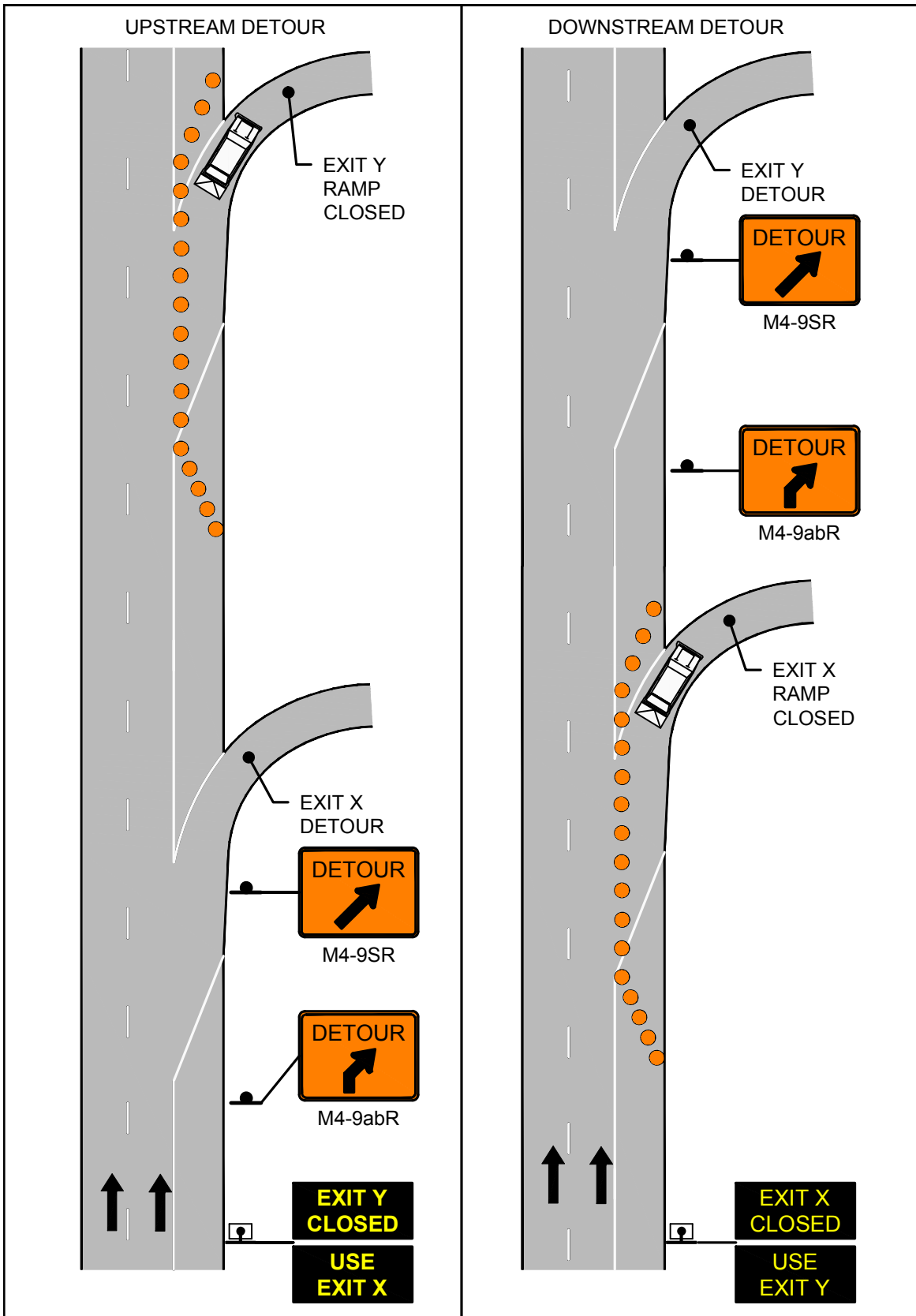



FIGURE 24-1  
MULTILANE DIVIDED ROADWAY  
PLACEMENT OF TEMPORARY  
PORTABLE RUMBLE STRIPS  
SHEET 1 OF 2



POSTED REGULATORY OR WORK ZONE SPEED	SEPARATION BETWEEN RUMBLE STRIPS
Above 55-mph	20-feet
36-mph to 55-mph	15-feet
35-mph and under	10-feet

POSTED SPEED LIMIT (MPH)	SPACING FOR ADVANCE WARNING SIGNS (FT) (A,B,C)	TANGENT LENGTH BETWEEN TAPERS (T) (FT)
25-40	500 / 500 / 500	640
45-55	500 / 1000 / 1000	1320
60-65	1000 / 1600 / 2600	1560

**NOTES**

1. THE INTENTION OF THESE DETAILS IS ONLY TO DEPICT THE PLACEMENT OF TEMPORARY PORTABLE RUMBLE STRIPS (TPRS) IN RELATIONSHIP TO THE TAPER AND THE BUFFER OF A SINGLE- OR MULTI-LANE CLOSURE. THE DEPICTION OF THE NUMBER AND SPACING OF ALL OTHER TRAFFIC CONTROL DEVICES IS NOT TO SCALE. REFER TO OTHER DETAILS FOR LANE CLOSURES FOR THE PLACEMENT AND NUMBER OF ALL OTHER TRAFFIC CONTROL DEVICES.
2. THESE DETAILS ONLY DEPICT RIGHT LANE CLOSURES. LEFT LANE CLOSURES SHOULD UTILIZE A MIRROR IMAGE OF THESE SETUPS, STARTING WITH CLOSURE OF THE LEFTMOST LANE.
3. ★ THIS TPRS ARRAY IS OPTIONAL AT THE ENGINEER'S DISCRETION. IF USED, IT SHOULD BE PLACED ADJACENT TO THE BUFFER.
4. DETAILS SHOW THE MINIMUM NUMBER OF TPRS REQUIRED. ADDITIONAL MAY BE USED IF CONDITIONS WARRANT.

**LEGEND**

-  CHANNELIZATION DEVICE
-  TRUCK MOUNTED ATTENUATOR
-  TEMPORARY PORTABLE RUMBLE STRIP

NOT TO SCALE

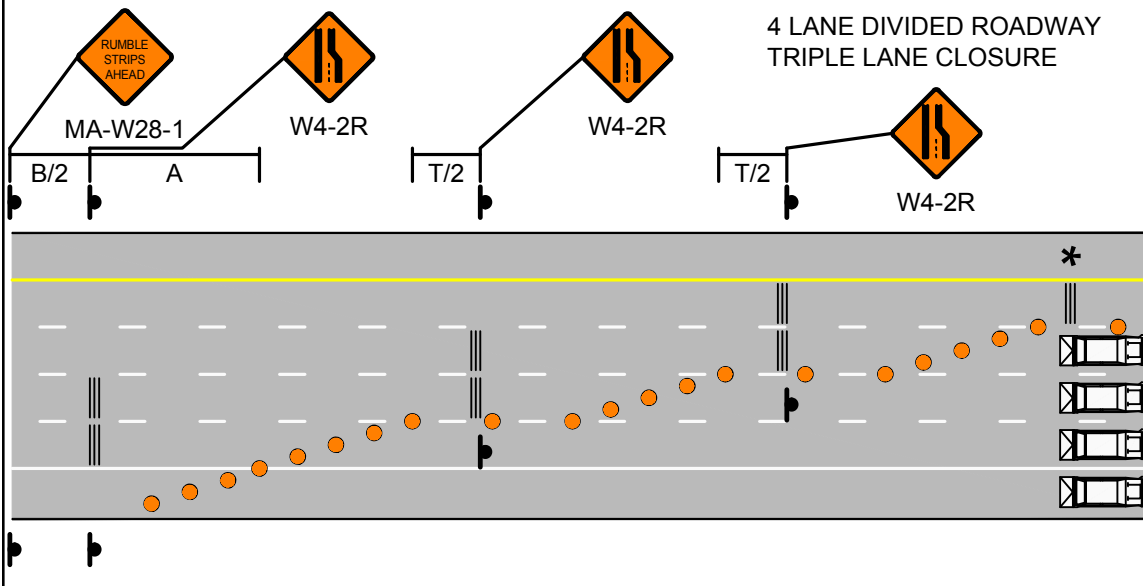

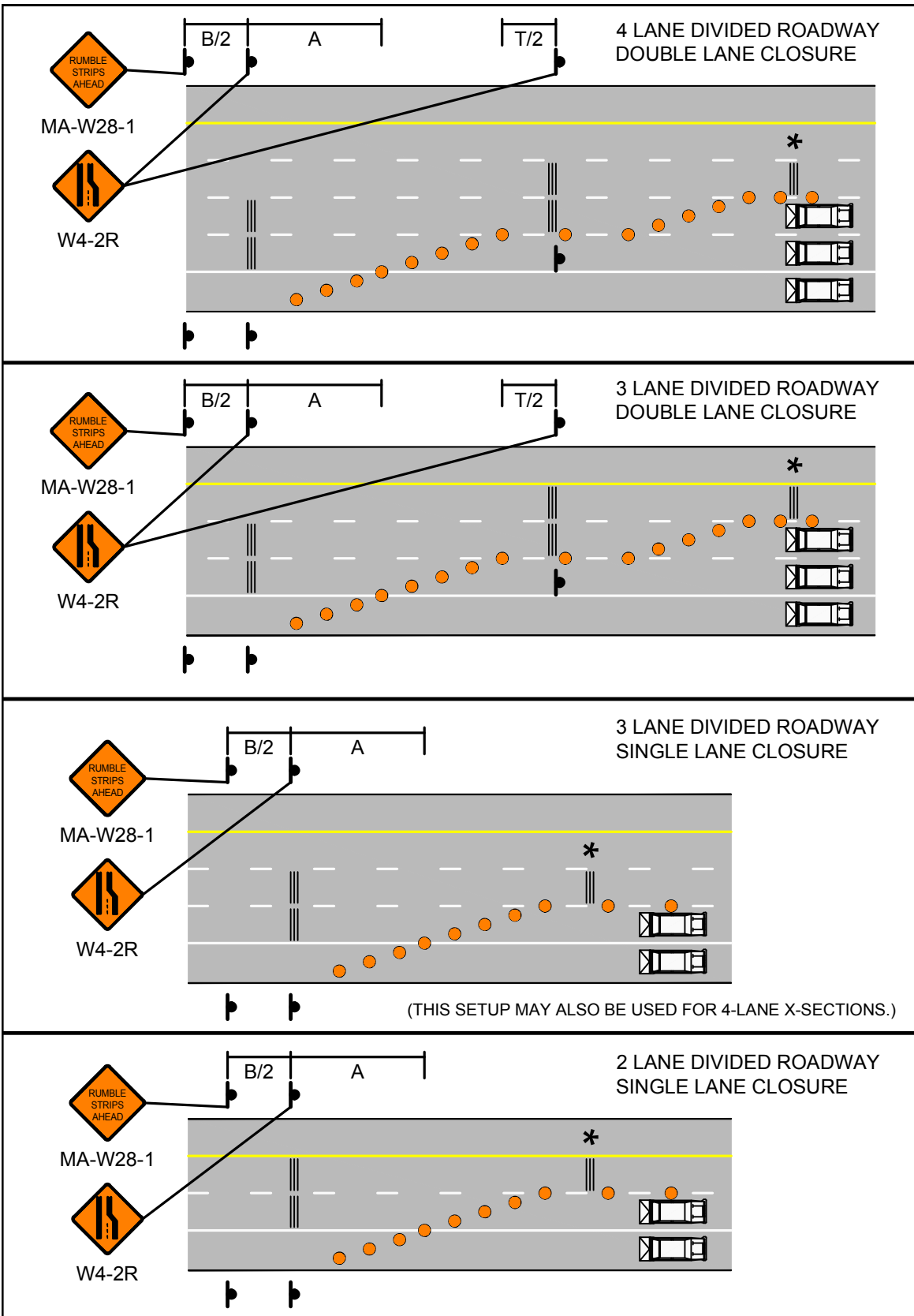

 <p>PAGE 56</p>	<p>Work Zone Safety Standard Details and Drawings</p>	<p>NOTES FOR MOBILE OPERATIONS</p>
--	---	------------------------------------

**Notes for Mobile Operations**

- Unless otherwise stated, these notes shall apply to all Mobile Operation setups.
  - Additional, setup-specific notes may be found on individual sheets.
1. The Supervisor shall travel the designated roadway prior to scheduling the work to ensure that sufficient and appropriate traffic control devices will be available. Special consideration shall be exercised to ensure that appropriate traffic controls be placed in areas that will have limited visibility of the work areas or any associated traffic queues.
  2. Vehicles used for these operations shall be made highly visible with appropriate equipment such as flashing lights, rotating beacons, flags, signs, flashing arrow boards, and/or portable changeable message signs. Any signs mounted to these vehicles shall not obscure the visibility of other devices.
  3. All vehicles shown may not be required based upon roadway conditions. However, when needed and practical, additional shadow vehicles and equipment to warn and protect motorists and workers should be used. Based upon roadway conditions, the addition of a police detail with cruiser may be used for additional protection or warning for the traveling public.
  4. The distance between the work and shadow vehicle(s) may vary according to the terrain and other factors. Shadow vehicles are used to warn traffic of the operations ahead. Whenever adequate sight distance exists, the shadow vehicle(s) should maintain the minimum appropriate distance and maintain the same speed to prevent non-work related vehicles from entering the work convoy. If this formation cannot be maintained then additional traffic control devices should be deployed in advance of any vertical or horizontal curves that may restrict the sight distance of an oncoming vehicle to either the work vehicle or associated traffic queue.
  5. All shadow vehicles shall be equipped with a truck or trailer mounted attenuator (TMA) and a flashing arrow board.
  6. Signs should be covered or turned from view when work is not in progress.
  7. Portable changeable message signs may be used in lieu of MA-W21-9 signs and any signs mounted directly to a shadow vehicle.

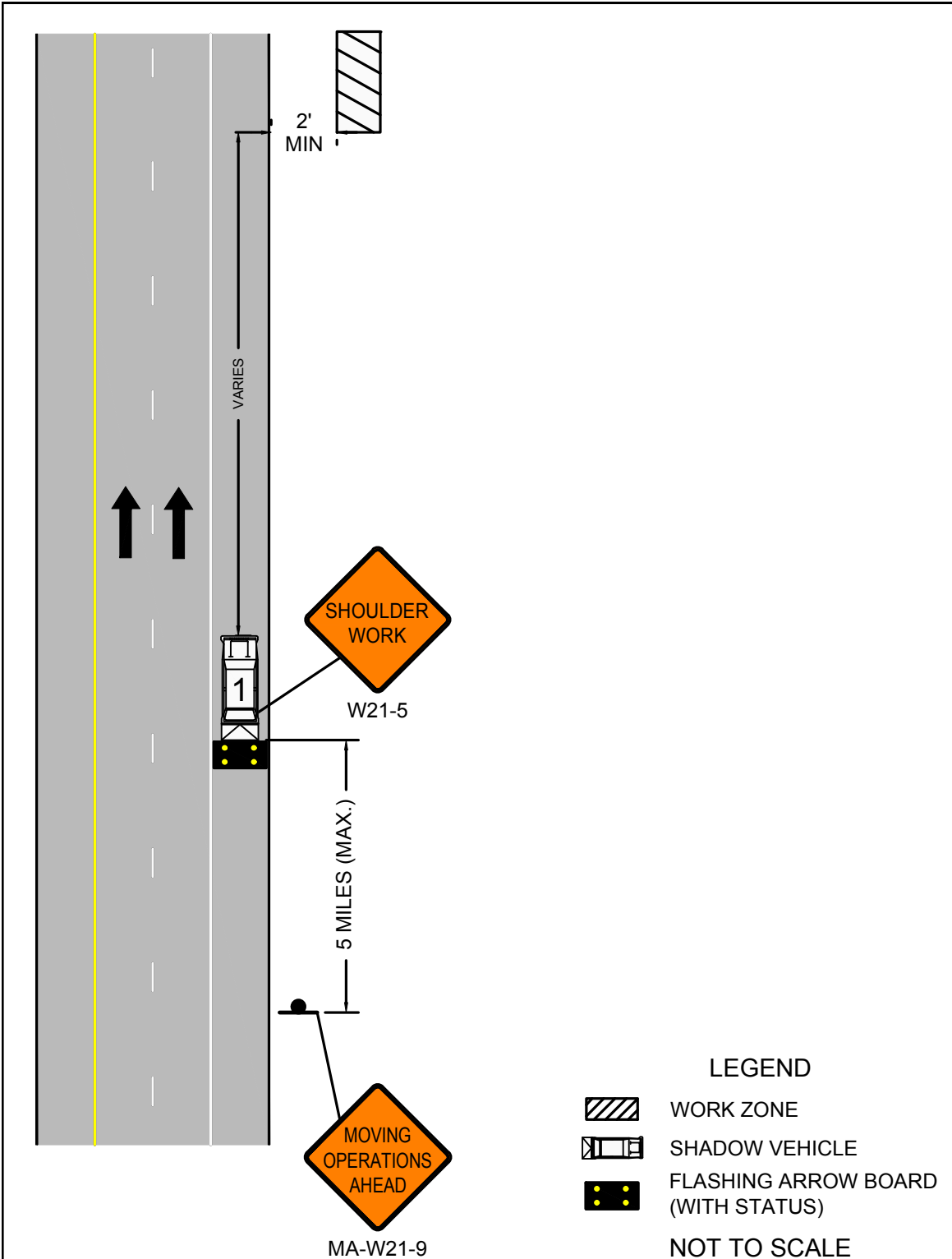

**NOTES**

1. IF THE WORK AREA IS SUFFICIENTLY AWAY FROM THE EDGE OF ROADWAY (20' MINIMUM) THEN SIGNS AND VEHICLES MAY NOT BE REQUIRED.

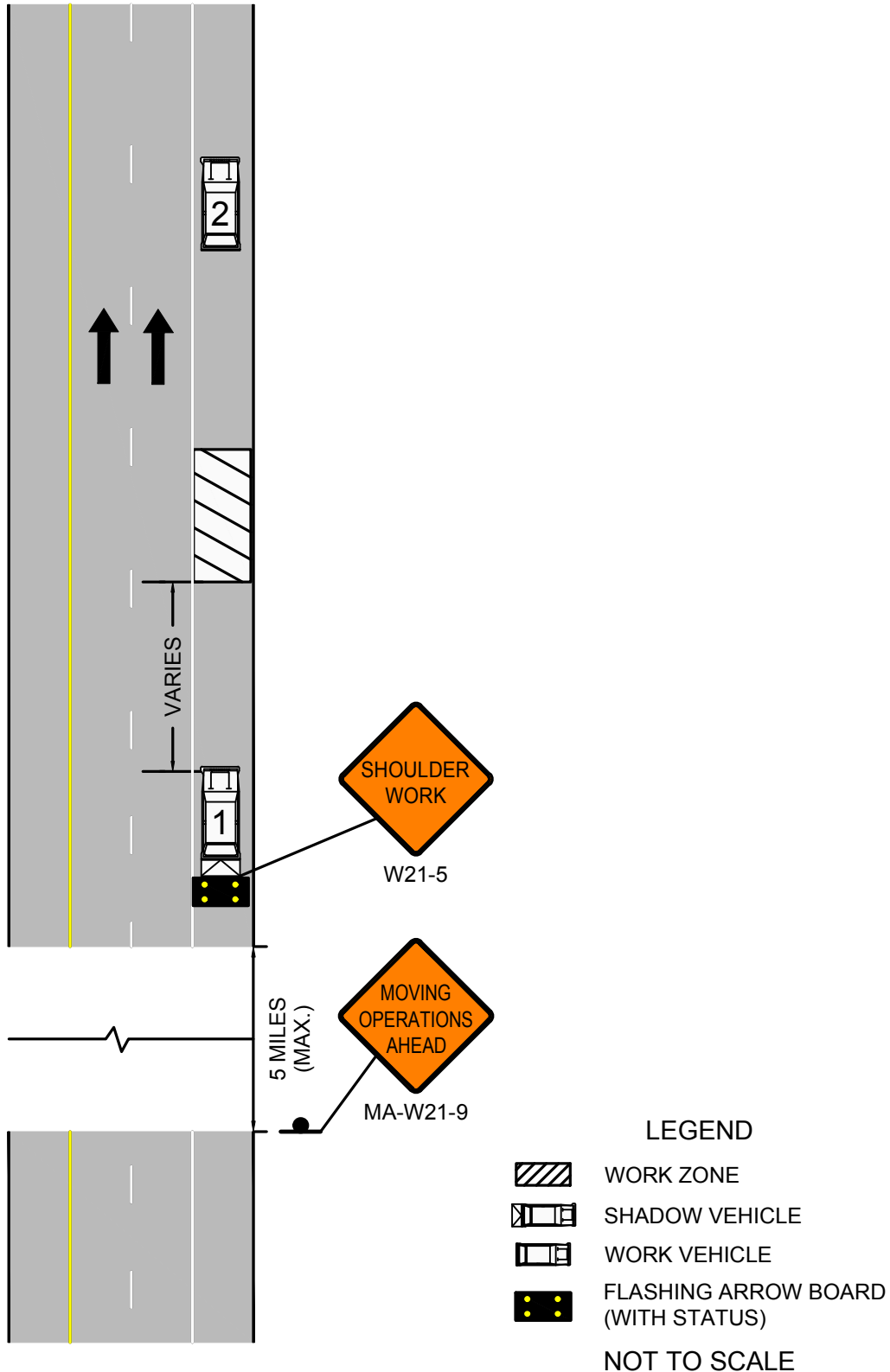

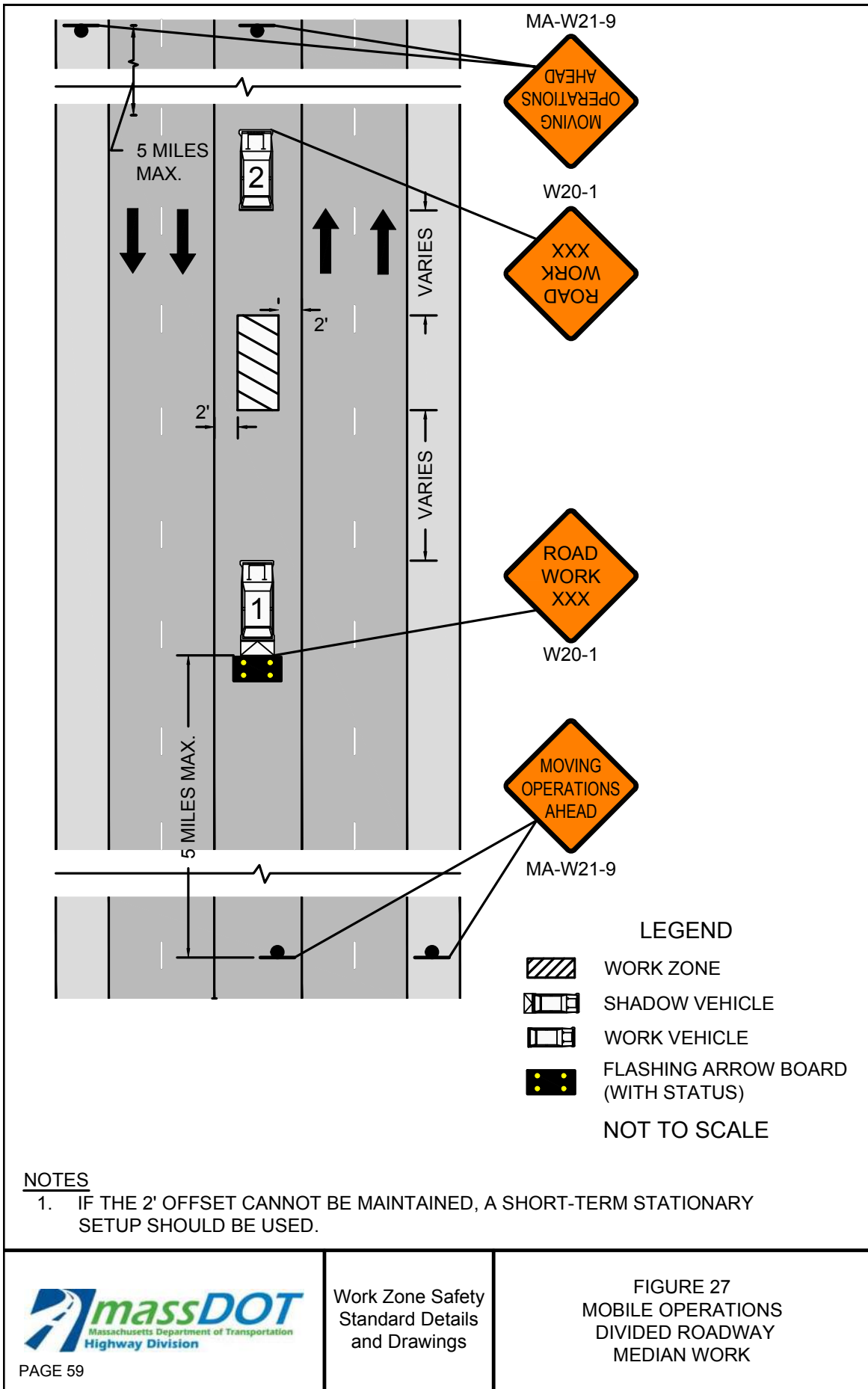



FIGURE 28  
MOBILE OPERATIONS  
UNDIVIDED TWO LANE ROADWAY  
HALF OF ROADWAY CLOSED

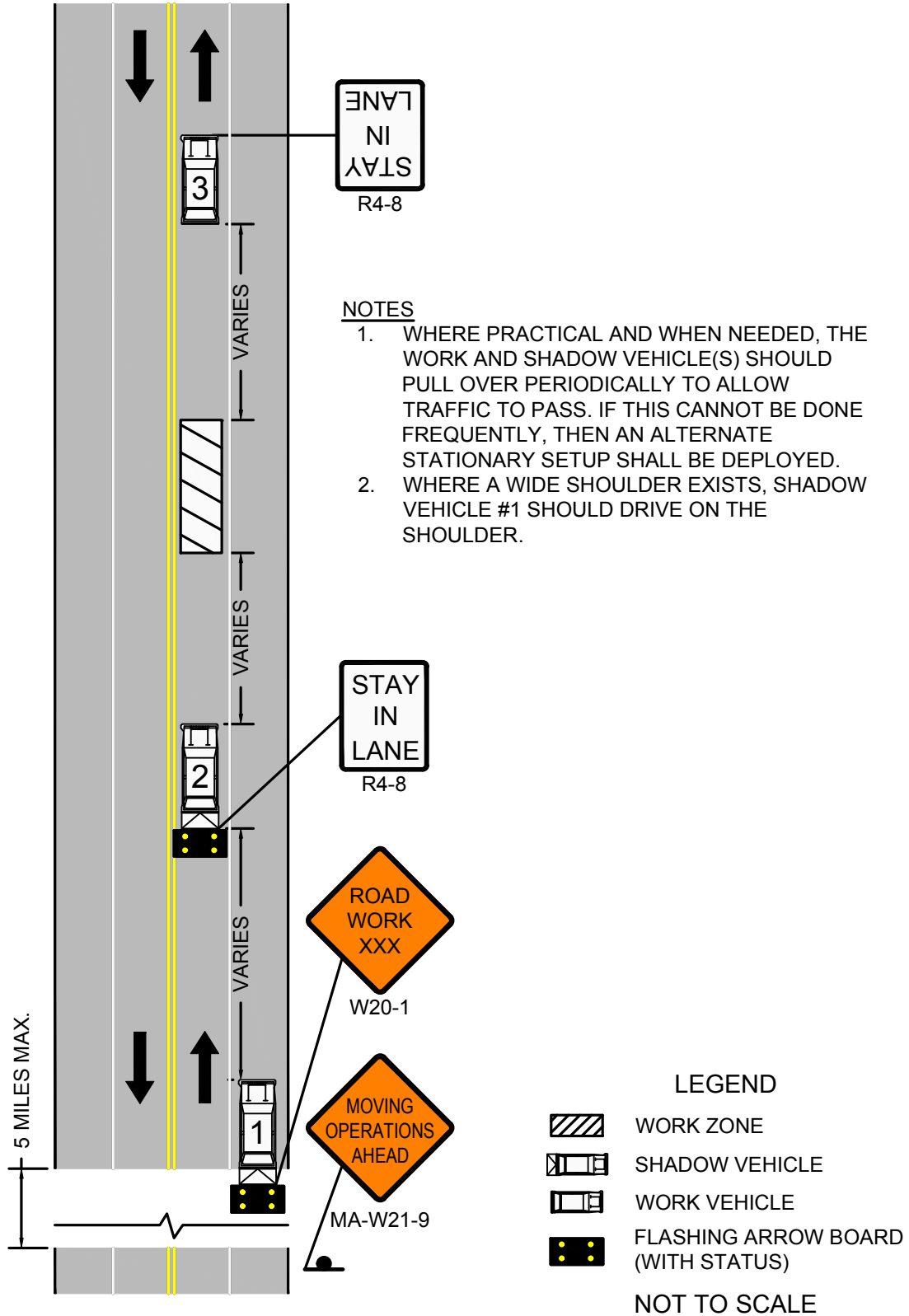
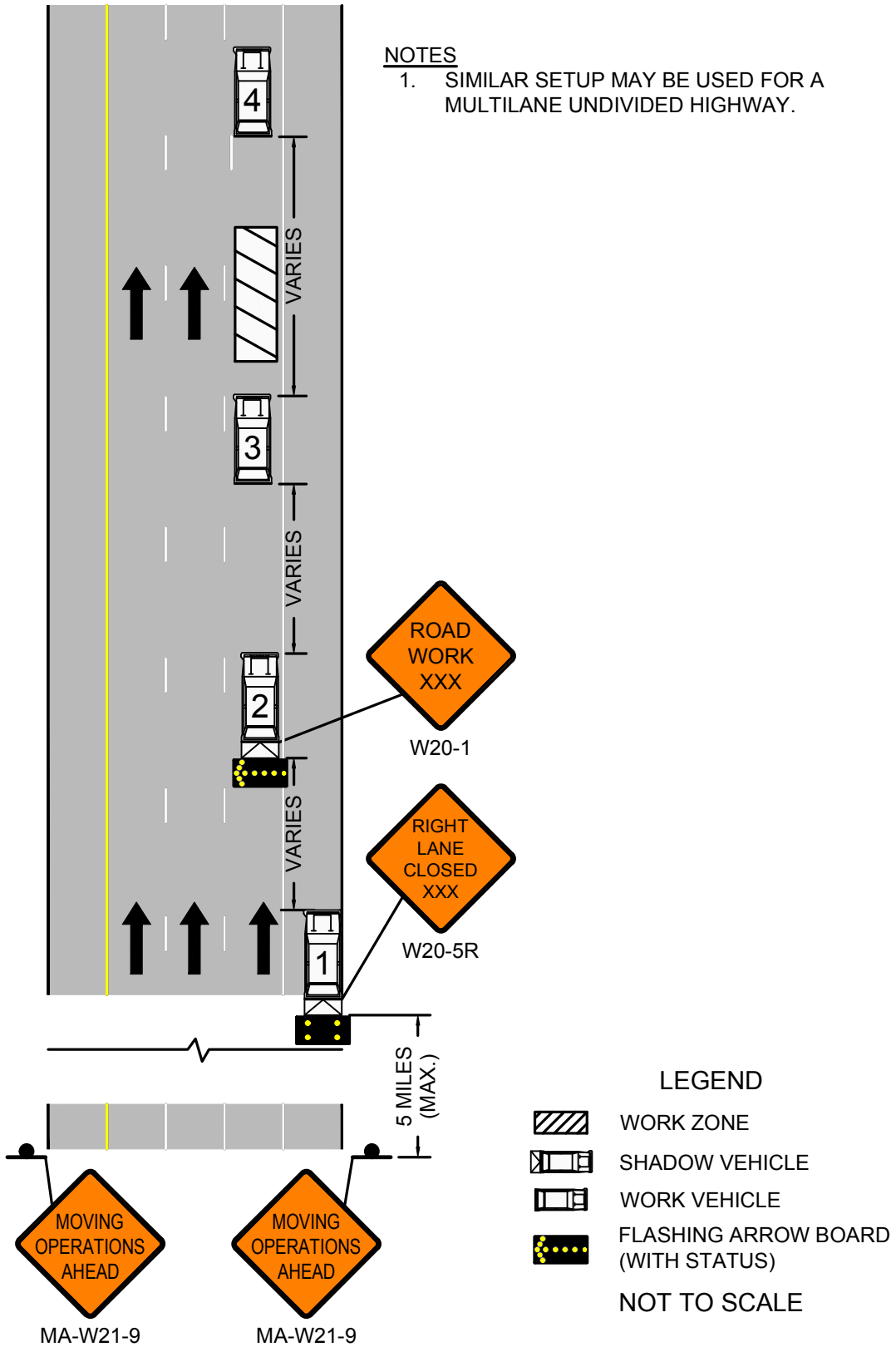
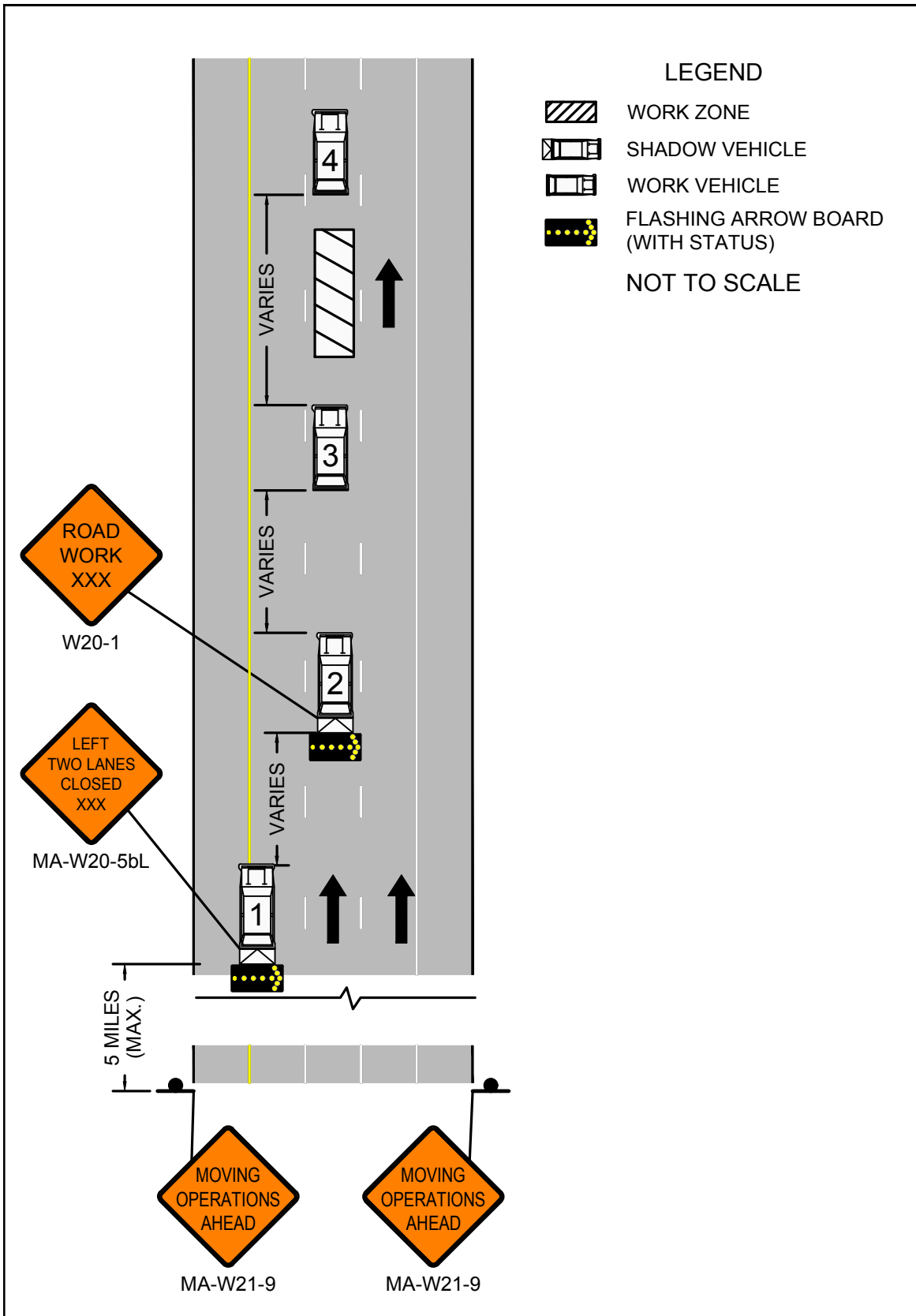

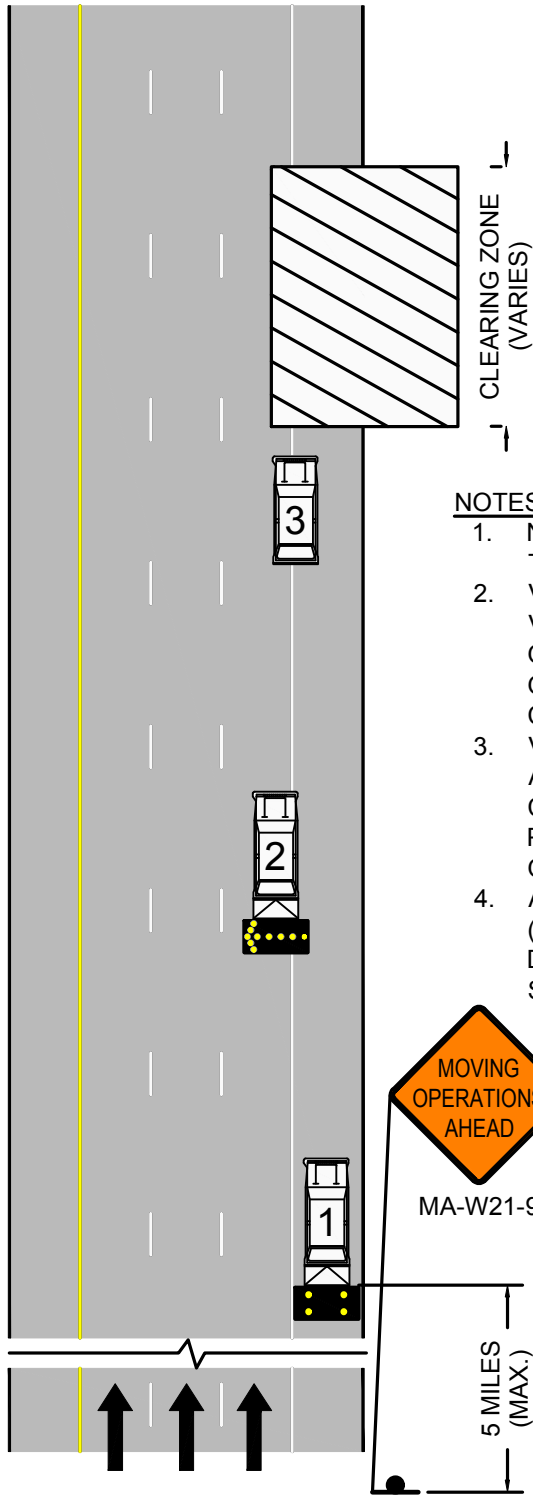



FIGURE 30  
MOBILE OPERATIONS  
MULTILANE DIVIDED ROADWAY  
RIGHT LANE











**NOTES**

1. NO OTHER NOTES ARE APPLICABLE TO THIS DETAIL.
2. VEHICLE #3 IS A SNOW/DEBRIS REMOVAL VEHICLE AND SHALL ALWAYS BE AWARE OF THE SURROUNDINGS. MORE THAN ONE VEHICLE MAY BE USED IN THE CLEARING ZONE.
3. VEHICLE #1 SHOULD BE EQUIPPED WITH A PCMS, A TMA, AND STAY IN VISUAL CONTACT WITH VEHICLE #3 WHILE PROVIDING AMPLE WARNING TO ONCOMING TRAFFIC.
4. A POLICE DETAIL WITH BLUE LIGHTS (OPTIONAL) SHALL REMAIN DOWNSTREAM OF VEHICLE #1 IN THE SHOULDER.

**LEGEND**

-  WORK ZONE
-  SHADOW VEHICLE
-  WORK VEHICLE
-  FLASHING ARROW BOARD (WITH STATUS)

NOT TO SCALE

**Notes for Traffic Emergency or Incident Operations**

- The goal is to increase awareness of during traffic emergencies or incidents.
- These signs are to be used to differentiate from the traditional construction work zone and an emergency or incident.
- Upon arrival MassDOT First Responders shall assess the magnitude of the scene to determine if the incident is likely to last an hour or more in duration which would trigger the requirement to use these signs.
- Place the “Emergency Ahead” sign on the same side of the road as the incident, if possible, for up to an hour. Emergency response signs should be put up for all incidents and emergencies as soon as possible.
- Place the emergency sign 500 to 1000 feet before the first channelization devices.
- As an incident evolves this sign would be used as a secondary sign with all other emergency controls put in place.
- Only use “MERGE” signs where applicable (Not on 2 lane roads).
- Use MERGE signs on Multi-lane Roads to move traffic away from the incident and keep them in a safe lane.
- Place the MERGE sign about 500 feet before the closure.
- If additional signs are available, they should be placed accordingly as a sign informing people coming in the other direction or on the opposite side of the roadway.
- Use 12 emergency cones spaced 40 to 80 feet apart to form a taper and protect the scene.
- Sequential flashing lights/flares may be used in lieu of or to supplement cones.
- During a major incident that will last for a long duration, the EMERGENCY AHEAD sign should be moved back before an intersecting road or ramp to alert travelers and give them an option of using an alternate route. (Be sure all other devices are in place before moving this sign).

**Standard Emergency Signs (36"x36" or 48"x48")**



MA-W20-9

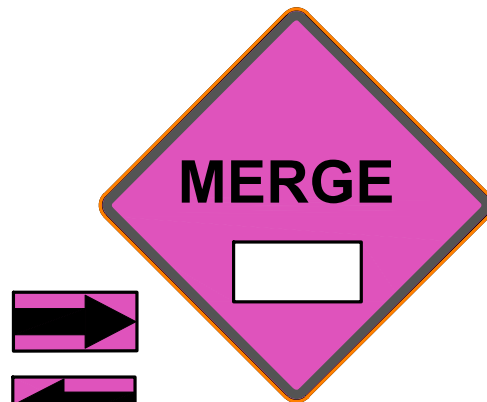



MA-W4-2aR/L



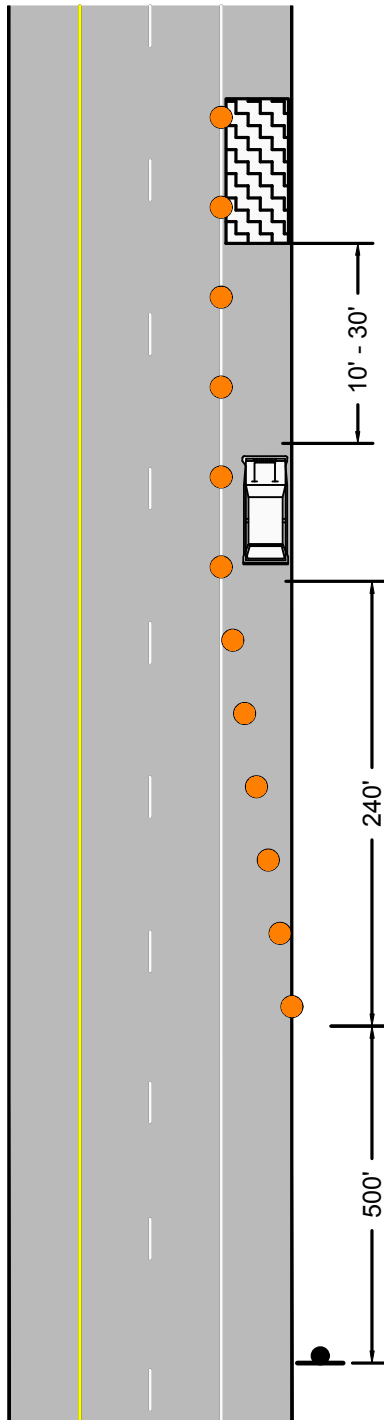

FIGURE 33  
EMERGENCY RESPONSE  
ANY ROADWAY  
SHOULDER ENCROACHMENT

LEGEND

-  EMERGENCY AREA
-  CHANNELIZATION DEVICE
-  EMERGENCY RESPONSE VEHICLE

NOT TO SCALE



ORDER OF RESPONSE ACTIVITIES

1. ACTIVATE HAZARD WARNING LIGHTS AND FLASHERS. PULL VEHICLE OVER TO THE RIGHT EDGE OF TRAVEL LANE BEFORE STOPPING.
2. IF EMERGENCY INVOLVES AN INJURY, SKIP TO STEP 4 THEN RETURN TO STEP 3.
3. ERECT SIGNS AND PLACE TRAFFIC CONES. USE 40' SPACING BETWEEN CONES.
4. TEND TO EMERGENCY/INCIDENT.

NOTES

1. ON HILLY TERRAIN, SHARP CURVES, IN HEAVY TRAFFIC, OR WITH HIGH SPEEDS, CONE SPACING MAY BE DOUBLED TO 80'.
2. REQUEST ADDITIONAL ASSISTANCE AND/OR TRAFFIC CONTROL DEVICES, IF NEEDED.



MA-W20-9

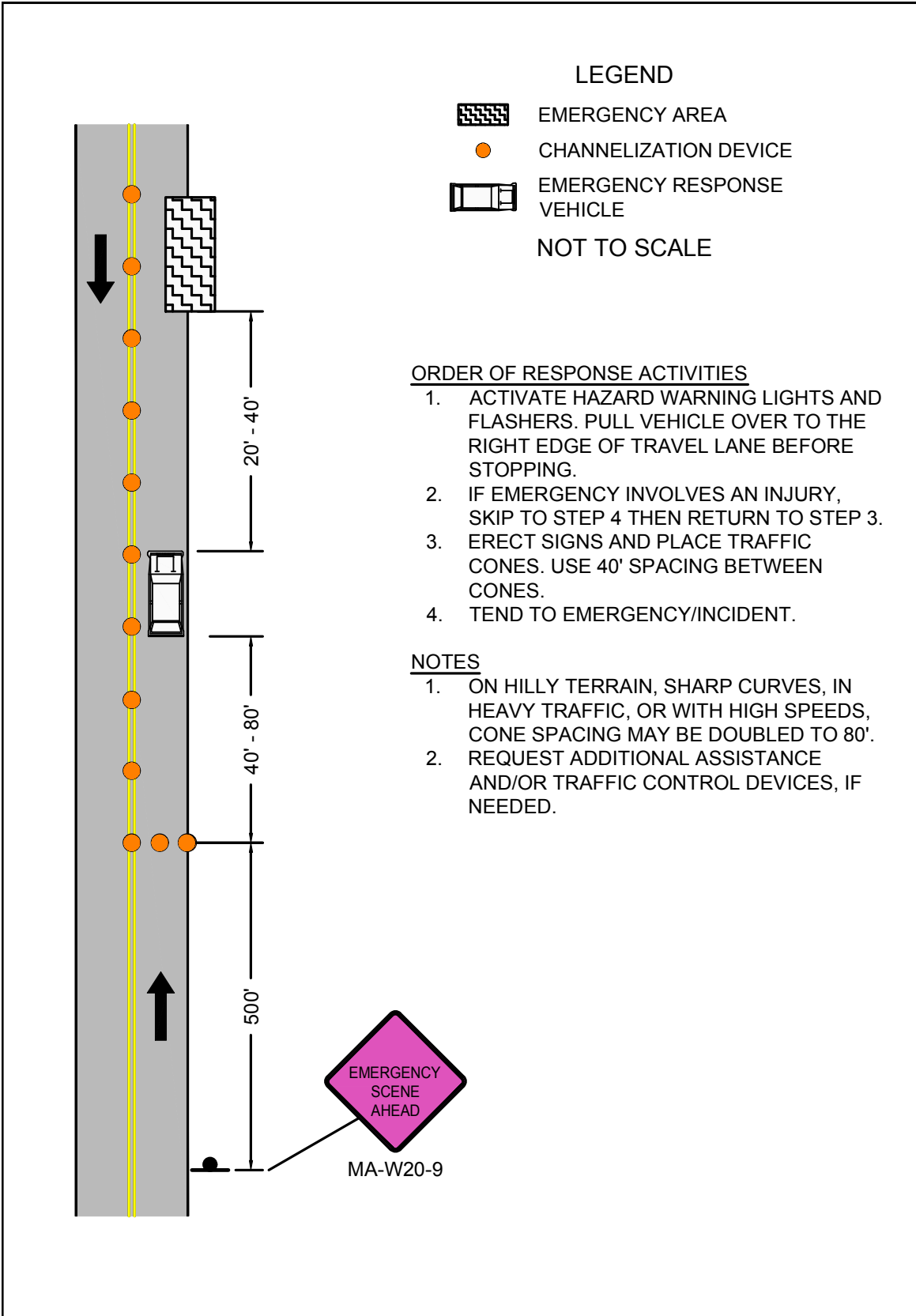





 Massachusetts Department of Transportation Highway Division PAGE 67	Work Zone Safety Standard Details and Drawings	<b>FIGURE 34</b> EMERGENCY RESPONSE TWO LANE ROADWAY NO SHOULDER TRAVEL LANE ENCROACHMENT
--	--	---

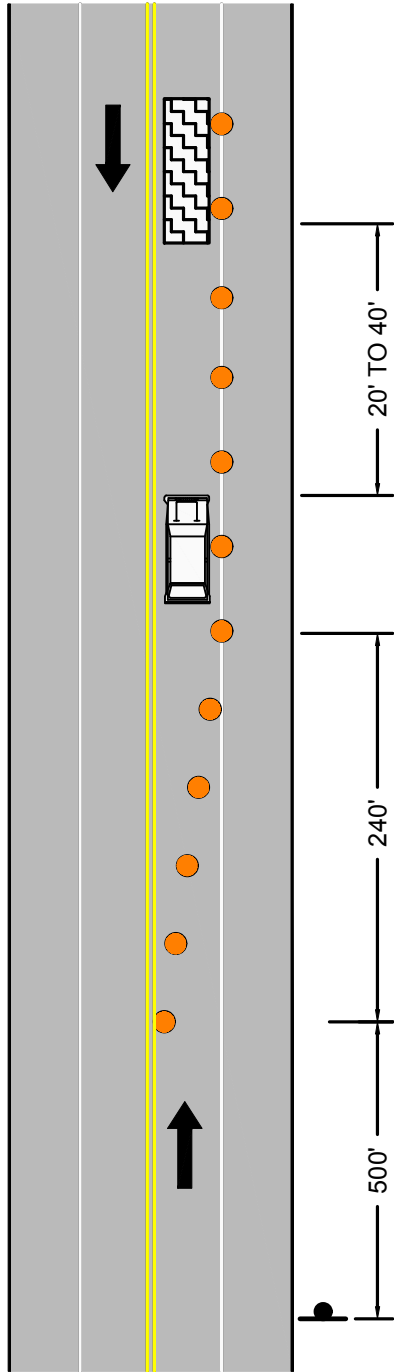

FIGURE 35  
EMERGENCY RESPONSE  
TWO LANE ROADWAY  
TRAVERSABLE SHOULDER  
SINGLE LANE ENCROACHMENT

LEGEND

-  EMERGENCY AREA
-  CHANNELIZATION DEVICE
-  EMERGENCY RESPONSE VEHICLE

NOT TO SCALE



ORDER OF RESPONSE ACTIVITIES

1. ACTIVATE HAZARD WARNING LIGHTS AND FLASHERS. PULL VEHICLE OVER TO THE LEFT EDGE OF TRAVEL LANE BEFORE STOPPING.
2. IF EMERGENCY INVOLVES AN INJURY, SKIP TO STEP 4 THEN RETURN TO STEP 3.
3. ERECT SIGNS AND PLACE TRAFFIC CONES. USE 40' SPACING BETWEEN CONES.
4. TEND TO EMERGENCY/INCIDENT.

NOTES

1. ON HILLY TERRAIN, SHARP CURVES, IN HEAVY TRAFFIC, OR WITH HIGH SPEEDS, CONE SPACING MAY BE DOUBLED TO 80'.
2. REQUEST ADDITIONAL ASSISTANCE AND/OR TRAFFIC CONTROL DEVICES, IF NEEDED.



MA-W20-9

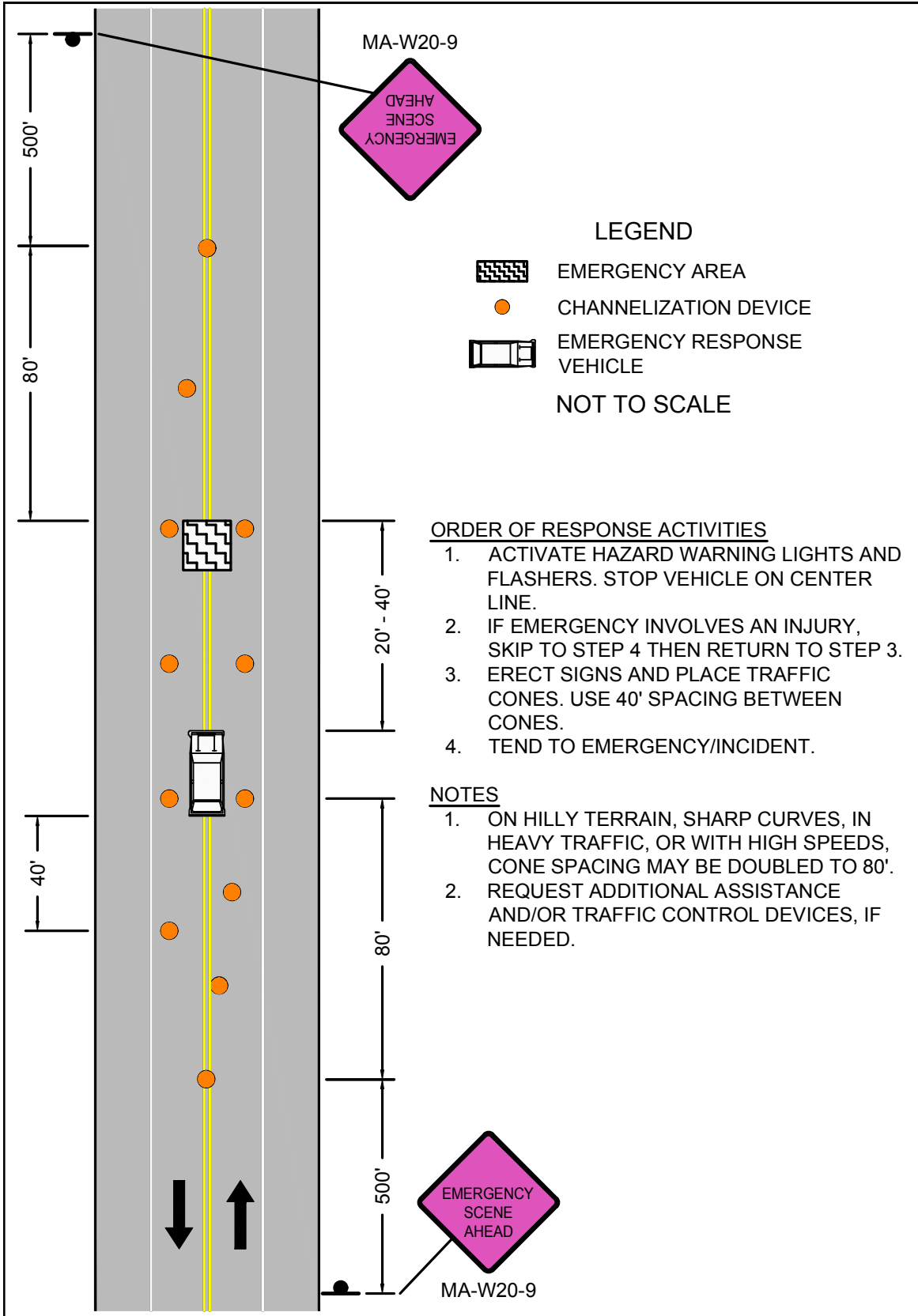





<p>Massachusetts Department of Transportation Highway Division</p> <p>PAGE 69</p>	<p>Work Zone Safety Standard Details and Drawings</p>	<p>FIGURE 36 EMERGENCY RESPONSE TWO LANE ROADWAY TRAVERSABLE SHOULDER CENTER OF ROADWAY</p>
---	---	---

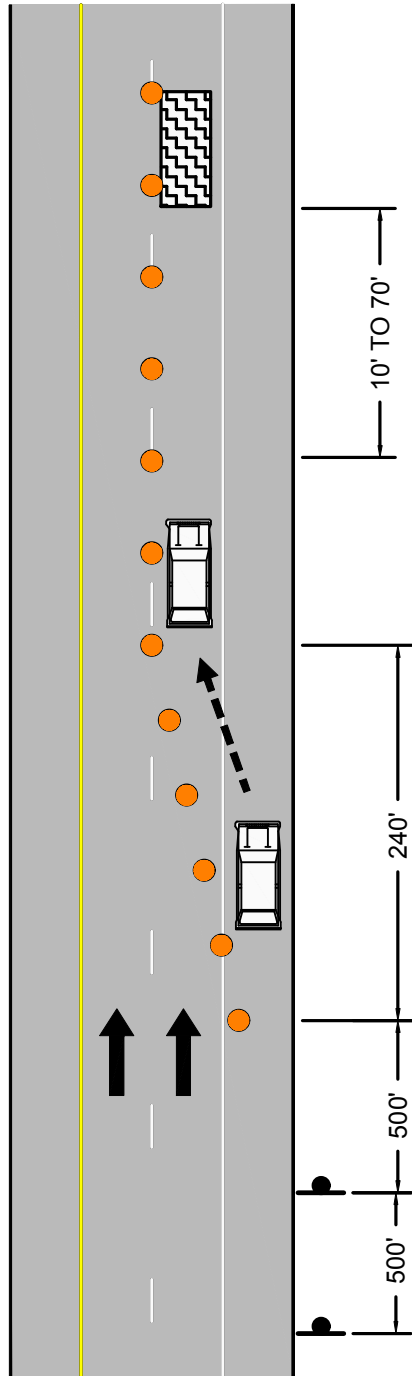

FIGURE 37  
EMERGENCY RESPONSE  
MULTILANE DIVIDED ROADWAY  
RIGHT LANE



LEGEND

-  EMERGENCY AREA
-  CHANNELIZATION DEVICE
-  EMERGENCY RESPONSE VEHICLE
-  RESPONSE VEHICLE MOVEMENT

NOT TO SCALE

ORDER OF RESPONSE ACTIVITIES

1. ACTIVATE HAZARD WARNING LIGHTS AND FLASHERS. STOP VEHICLE IN BREAKDOWN LANE.
2. IF EMERGENCY INVOLVES AN INJURY, SKIP TO STEP 6 THEN RETURN TO STEP 3.
3. ERECT SIGNS AND PLACE TRAFFIC CONES. USE 40' SPACING BETWEEN CONES.
4. MOVE RESPONSE VEHICLE BEHIND EMERGENCY.
5. PLACE ADDITIONAL CONES.
6. TEND TO EMERGENCY.

NOTES

1. ON HILLY TERRAIN, SHARP CURVES, IN HEAVY TRAFFIC, OR WITH HIGH SPEEDS, CONE SPACING MAY BE DOUBLED TO 80'.
2. REQUEST ADDITIONAL ASSISTANCE AND/OR TRAFFIC CONTROL DEVICES, IF NEEDED.

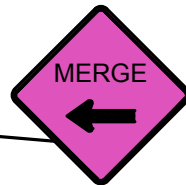

MA-W4-2aL

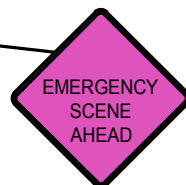

MA-W20-9

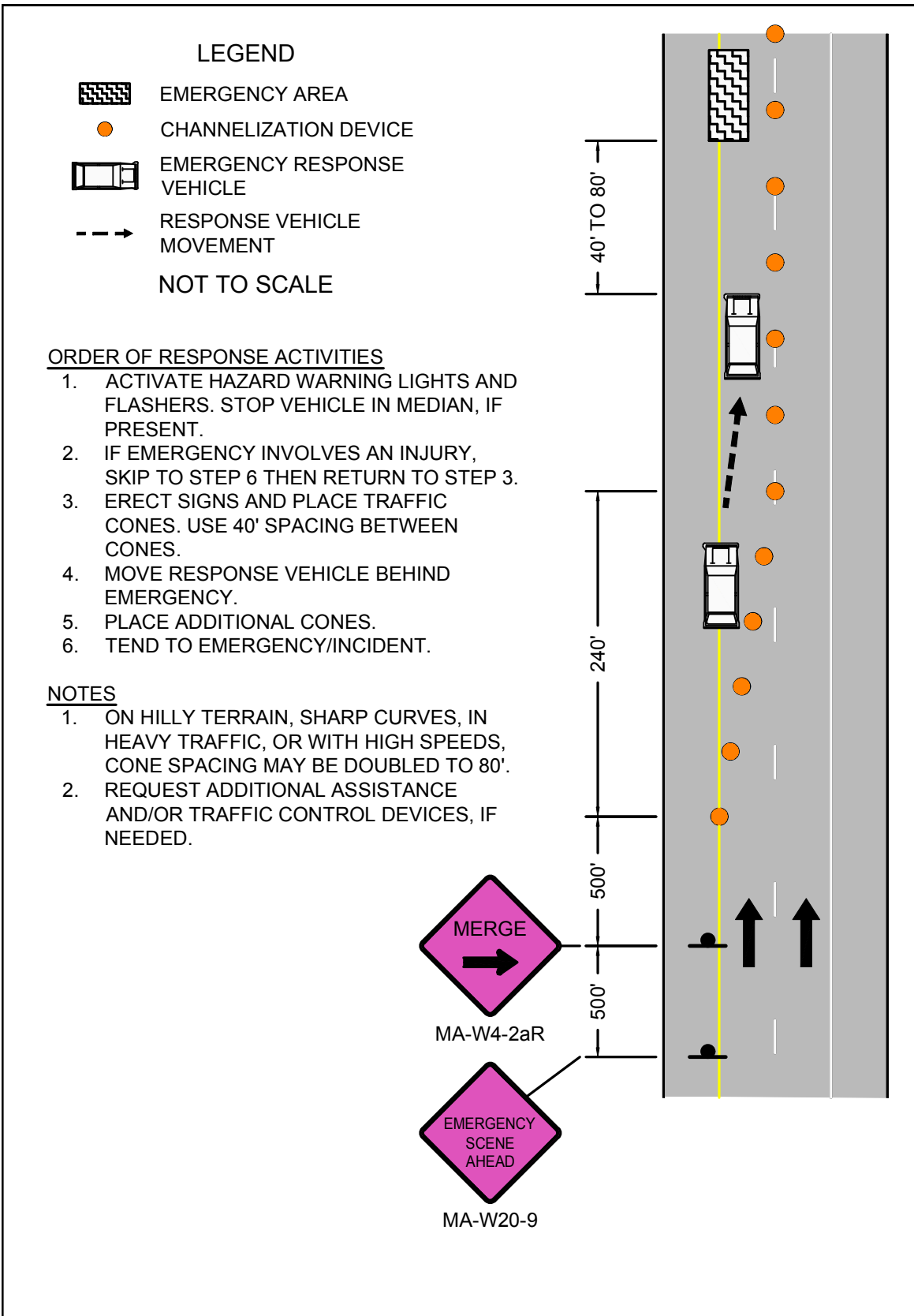
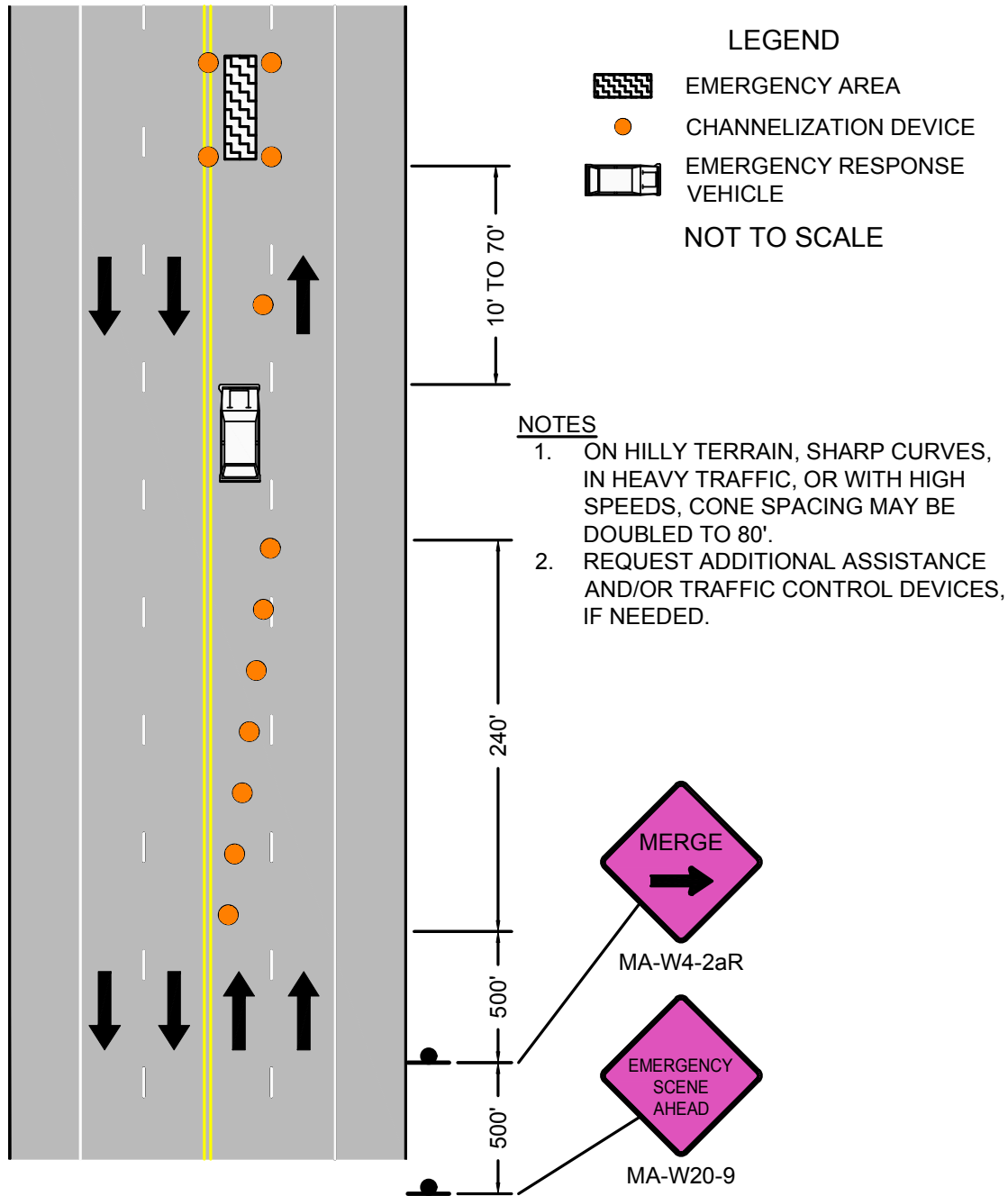

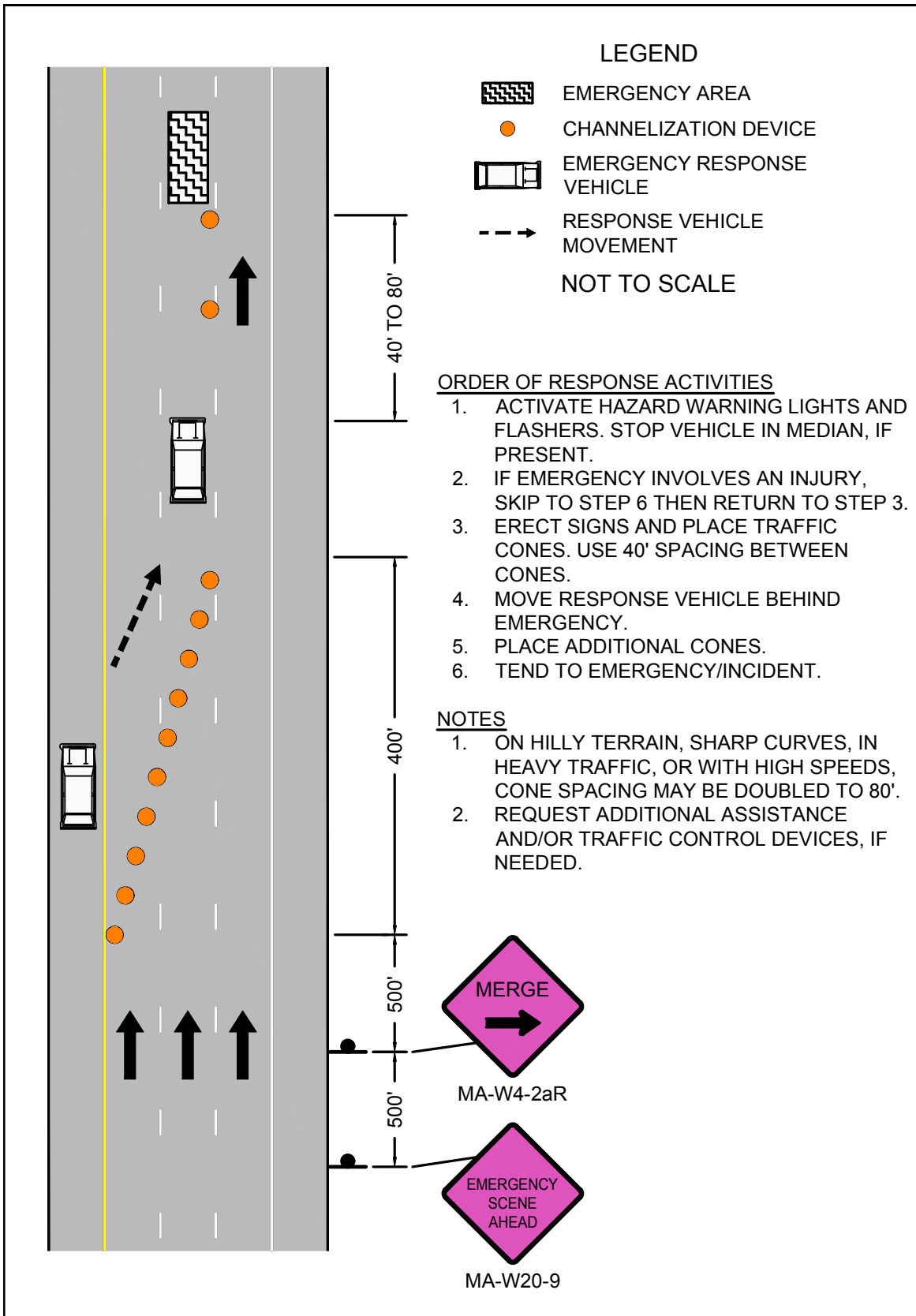

FIGURE 39  
EMERGENCY RESPONSE  
MULTILANE UNDIVIDED  
ROADWAY  
LEFT LANE



**ORDER OF RESPONSE ACTIVITIES**

1. ACTIVATE HAZARD WARNING LIGHTS AND FLASHERS. PULL VEHICLE OVER TO THE RIGHT EDGE OF BREAKDOWN LANE OR SHOULDER OR, IF NOT PRESENT, RIGHT EDGE OF TRAVEL LANE BEFORE STOPPING.
2. IF EMERGENCY INVOLVES AN INJURY, SKIP TO STEP 4 THEN RETURN TO STEP 3.
3. ERECT SIGNS AND PLACE TRAFFIC CONES. USE 40' SPACING BETWEEN CONES.
4. TEND TO EMERGENCY/INCIDENT.







 <p>Massachusetts Department of Transportation Highway Division</p>	<p>Work Zone Safety Standard Details and Drawings</p>	<p><b>FIGURE 40</b> EMERGENCY RESPONSE MULTILANE DIVIDED ROADWAY MIDDLE LANE APPROACH FROM LEFT</p>
--	---	---



FIGURE 41  
EMERGENCY RESPONSE  
MULTILANE DIVIDED ROADWAY  
MIDDLE LANE  
APPROACH FROM RIGHT

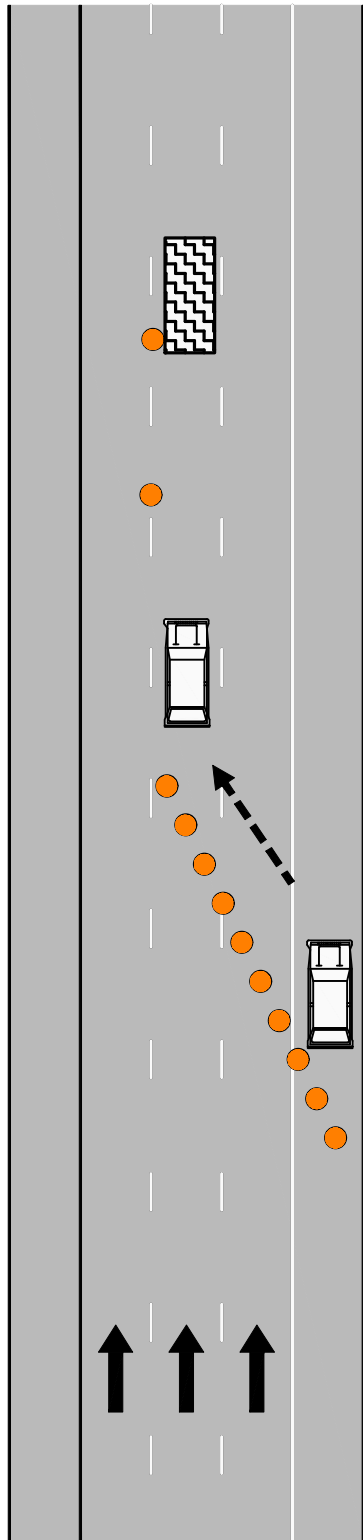

LEGEND

-  EMERGENCY AREA
-  CHANNELIZATION DEVICE
-  EMERGENCY RESPONSE VEHICLE
-  RESPONSE VEHICLE MOVEMENT

NOT TO SCALE

ORDER OF RESPONSE ACTIVITIES

1. ACTIVATE HAZARD WARNING LIGHTS AND FLASHERS. STOP VEHICLE IN BREAKDOWN LANE.
2. IF EMERGENCY INVOLVES AN INJURY, SKIP TO STEP 6 THEN RETURN TO STEP 3.
3. ERECT SIGNS AND PLACE TRAFFIC CONES. USE 40' SPACING BETWEEN CONES.
4. MOVE RESPONSE VEHICLE BEHIND EMERGENCY.
5. PLACE ADDITIONAL CONES.
6. TEND TO EMERGENCY.

NOTES

1. ON HILLY TERRAIN, SHARP CURVES, IN HEAVY TRAFFIC, OR WITH HIGH SPEEDS, CONE SPACING MAY BE DOUBLED TO 80'.
2. REQUEST ADDITIONAL ASSISTANCE AND/OR TRAFFIC CONTROL DEVICES, IF NEEDED.

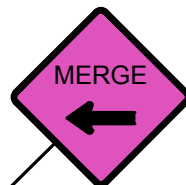



MA-W4-2aL

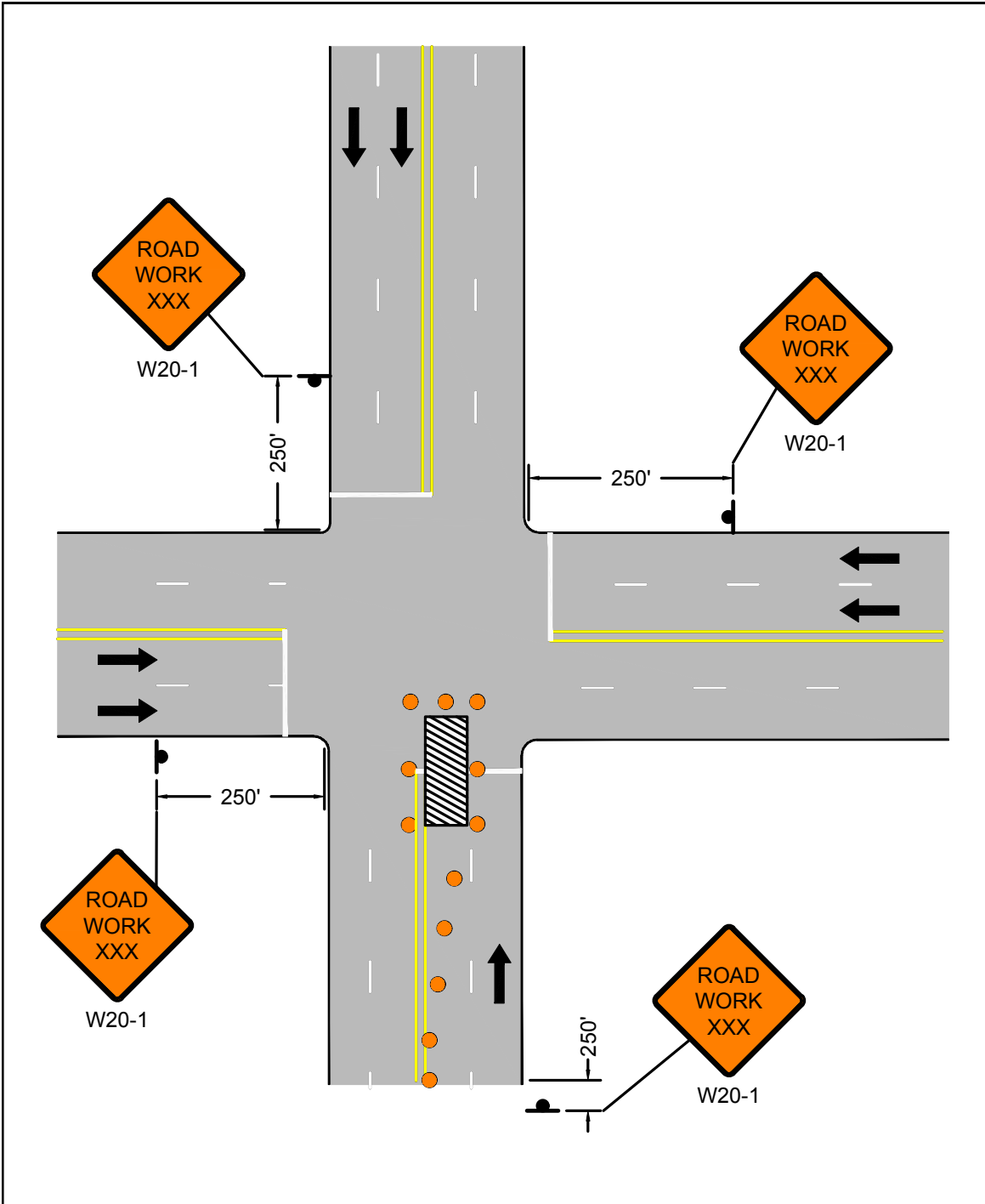

MA-W20-9



**LEGEND**

-  WORK ZONE
-  CHANNELIZATION DEVICE

NOT TO SCALE

**NOTES**

1. DURATION OF WORK = 20 MINUTES OR LESS.
2. EQUIPMENT: 12 CONES + 4 PORTABLE SIGNS.
3. CONE SPACING IS 20 FEET.
4. SINGLE WORK VEHICLE PARKED/STOPPED.
5. POLICE DETAIL REQUIRED.





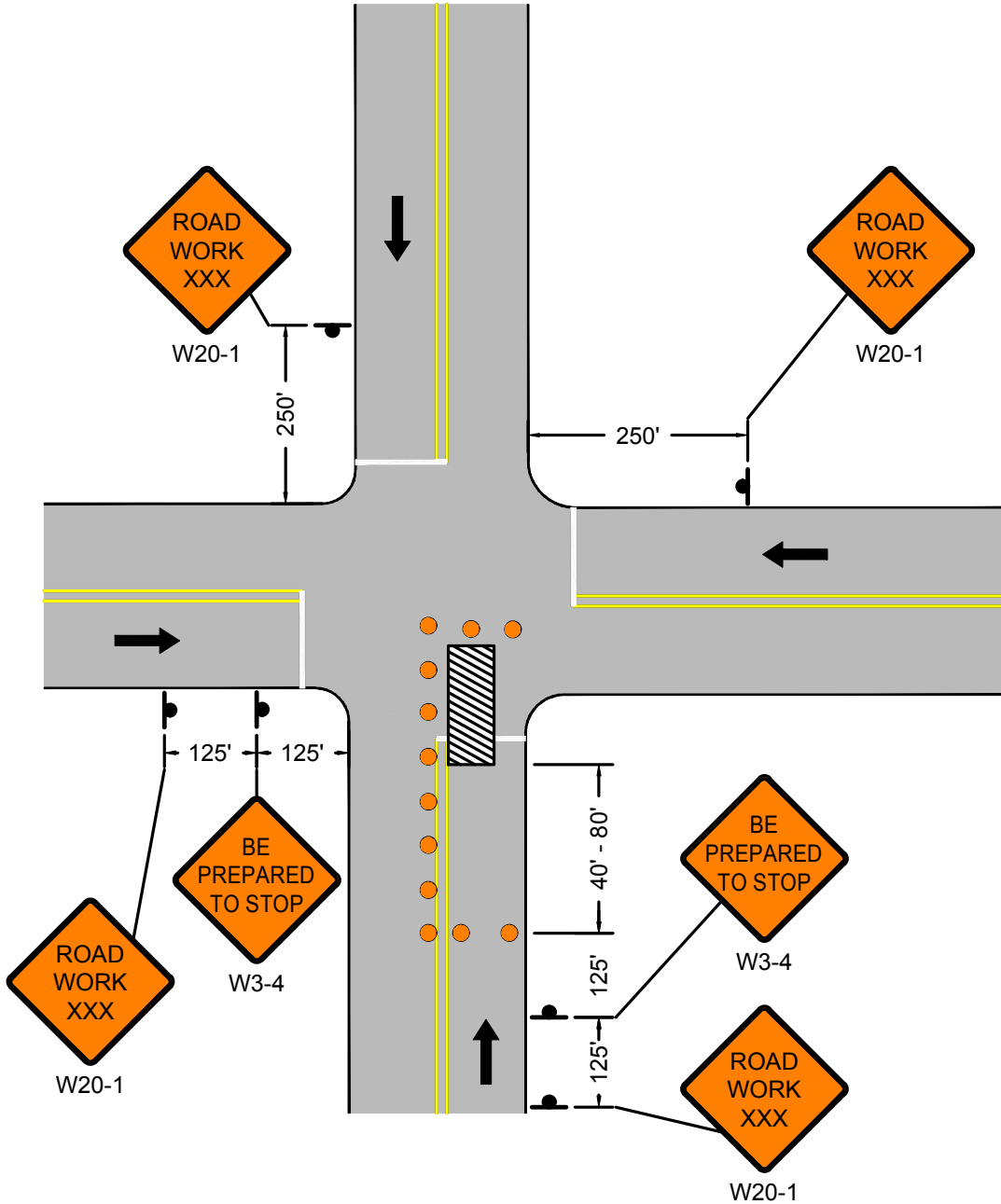

FIGURE 43  
TRAFFIC SIGNAL REPAIR WORK  
TWO LANE UNDIVIDED ROADWAY  
ONE LEG OF INTERSECTION



LEGEND

-  WORK ZONE
-  CHANNELIZATION DEVICE
- NOT TO SCALE

NOTES

1. DURATION OF WORK = 20 MINUTES OR LESS.
2. EQUIPMENT: 12 CONES + 6 PORTABLE SIGNS.
3. CONE SPACING IS 20 FEET.
4. SINGLE WORK VEHICLE PARKED/STOPPED.
5. POLICE DETAIL REQUIRED.

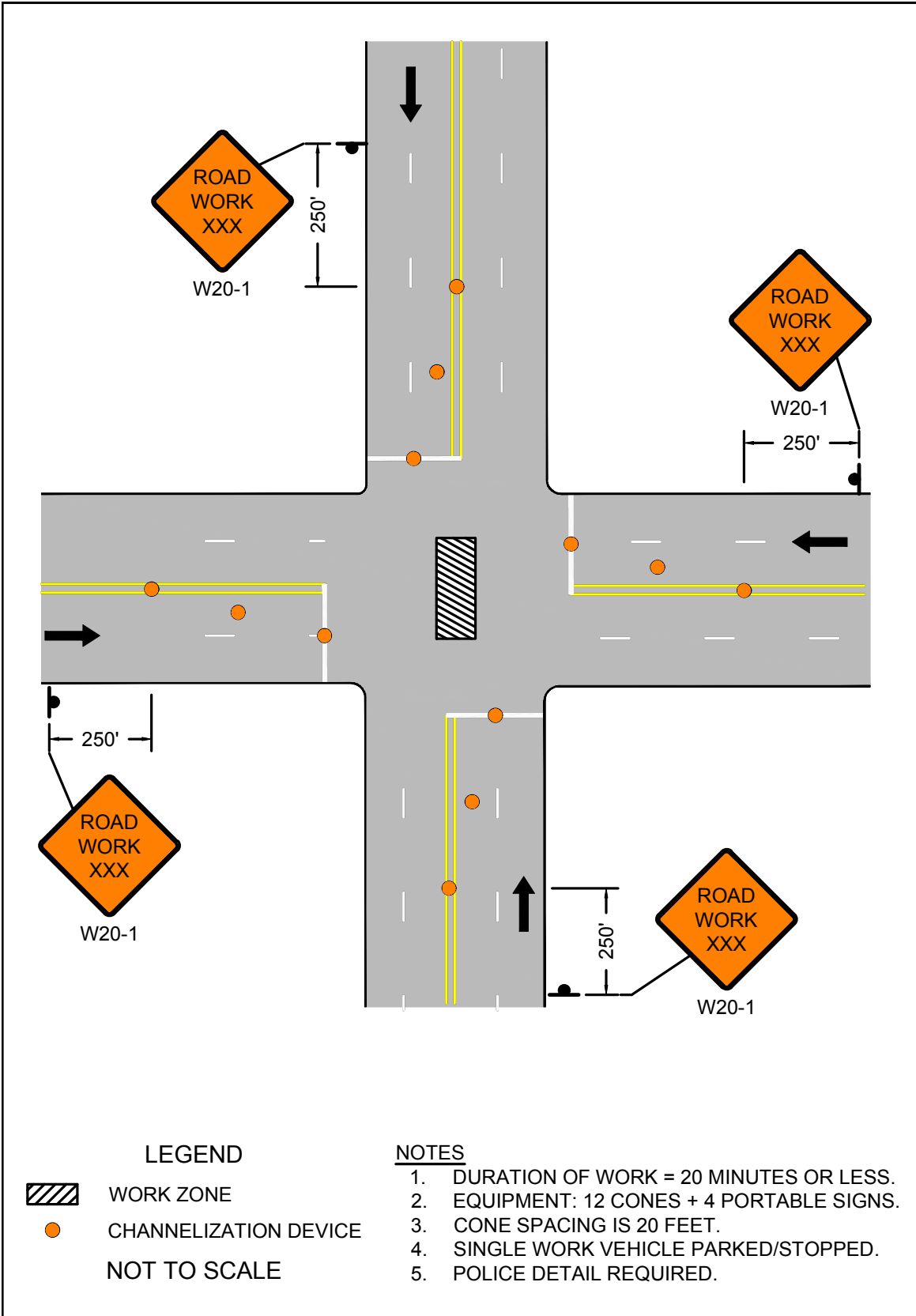



PAGE 78

Work Zone Safety  
Standard Details  
and Drawings

FIGURE 45  
PEDESTRIAN BYPASS

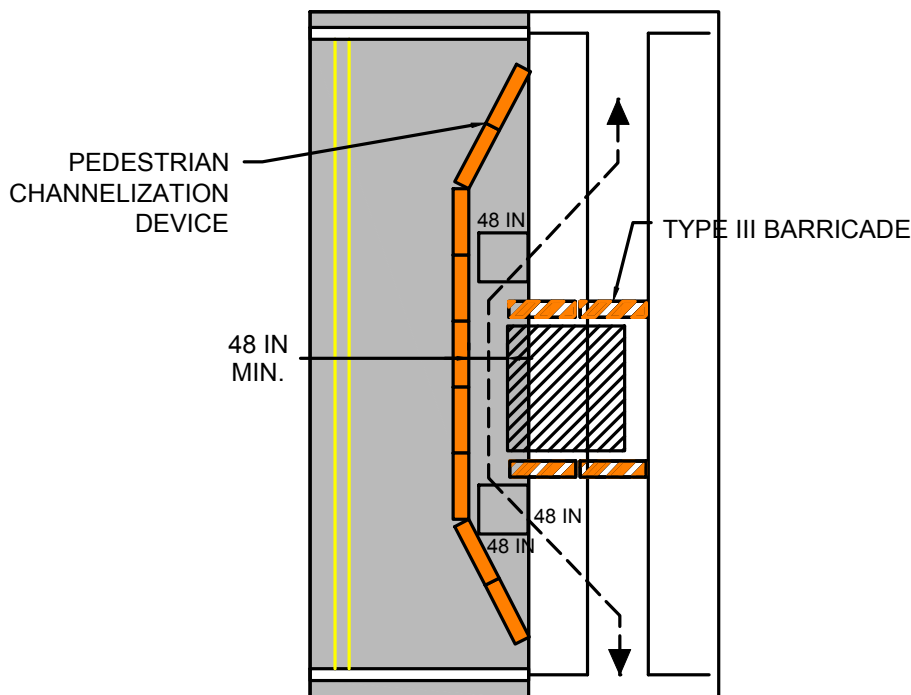

**NOTES:**

1. WHEN EXISTING PEDESTRIAN FACILITIES ARE DISRUPTED, CLOSED, OR RELOCATED IN A TTC ZONE, TEMPORARY FACILITIES SHALL BE PROVIDED AND THEY SHALL BE DETECTABLE AND INCLUDE ACCESSIBILITY FEATURES CONSISTENT WITH THE FEATURES PRESENT IN THE EXISTING PEDESTRIAN FACILITY.
2. A PEDESTRIAN CHANNELIZATION DEVICE THAT IS DETECTABLE BY A PERSON WITH A VISUAL DISABILITY TRAVELING WITH THE AID OF A LONG CANE SHALL BE PLACED ALONG THE FULL LENGTH OF THE TEMPORARY PEDESTRIAN ROUTE.
3. WHEN USED, TEMPORARY RAMPS SHALL COMPLY WITH AMERICANS WITH DISABILITIES ACT.
4. THE ALTERNATE PATHWAY SHOULD HAVE A SMOOTH CONTINUOUS HARD SURFACE FOR THE ENTIRE LENGTH OF THE TEMPORARY PEDESTRIAN FACILITY.
5. THE TEMPORARY SIDEWALK SHOULD BE A MINIMUM OF 4 FEET WIDE. IF THE SIDEWALK EXCEEDS 200 FEET THEN A 5 FOOT BY 5 FOOT PASSING ZONE SHALL BE PROVIDED NEAR THE MID-POINT OF THE CLOSURE.
6. THE PROTECTIVE REQUIREMENTS OF A TTC WORK ZONE MAY HAVE AN IMPACT IN DETERMINING THE NEED FOR TEMPORARY TRAFFIC BARRIERS AND THEIR USE IN PROVIDING PEDESTRIAN DELINEATION SHOULD BE BASED ON ENGINEERING JUDGMENT.
7. ON-DEMAND PEDESTRIAN ASSISTANCE PERSONNEL TO ASSIST WITH NAVIGATION AROUND THE CLOSURE/WORK AREA MAY BE CONSIDERED AS AN OPTION IN PLACE OF PROVIDING ADA/AAB DEVICES FOR WORK FOR CLOSURES LASTING 4 HOURS OR LESS.
8. CONTROLS ONLY FOR PEDESTRIAN TRAFFIC ARE SHOWN; VEHICULAR TRAFFIC SHOULD BE HANDLED AS SHOWN ELSEWHERE. THESE DETAILS ARE USED IN CONJUNCTION WITH THE PROPOSED LANE CLOSURE DETAILS AND DURING CONSTRUCTION STAGING, AS DETERMINED BY THE ENGINEER.

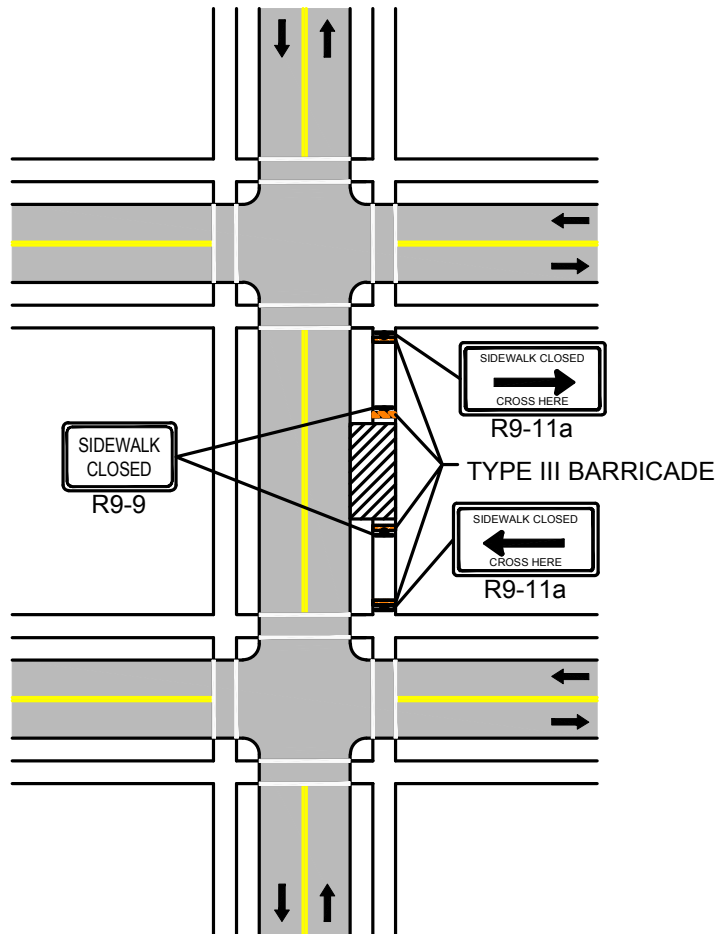

**NOTES:**

1. CLOSURE OF A SIDEWALK FACILITY SHALL CONSTITUTE THE PROVISION FOR MANAGING PEDESTRIAN TRAFFIC AND ACCOMMODATING ALL USERS. IF THE EXISTING PEDESTRIAN ACCESS ROUTE(S) CAN BE TEMPORARILY RELOCATED ALONG THE EXISTING SIDEWALK , AND SAID FACILITY PROVIDES A MINIMUM WIDTH OF 48-INCHES OF SOLID, SMOOTH UNOBSTRUCTED SURFACE, THEN NO DETOURING OF THE ROUTE SHALL BE REQUIRED. DELINEATION OF THE WORK AREA IS STILL REQUIRED.
2. IF IT IS NECESSARY TO DIVERT PEDESTRIAN TRAFFIC TO AN ALTERNATE ROUTE ACROSS THE ROADWAY FROM THE EXISTING FACILITY, THE FIGURE ABOVE SHALL BE FOLLOWED TO PROVIDE ADEQUATE DIRECTION TO PEDESTRIANS. ALTERNATE ROUTE SHALL PROVIDE THE SAME LEVEL OF ACCOMMODATION AS THE FACILITY THAT IS BEING DETOURED AND RETAIN ADA COMPLIANCE IN ITS ENTIRETY.
3. FOR EMERGENCY OR SHORT-DURATION SIDEWALK CLOSURES OF 4-HOURS OR LESS, IT IS OPTIONAL TO HAVE ON-DEMAND PEDESTRIAN ASSISTANCE PERSONNEL AVAILABLE AT ALL TIMES DURING THE CLOSURE TO ASSIST THOSE MOBILITY CHALLENGED PERSONS WHO REQUIRE ADDITIONAL ASSISTANCE TO SAFELY NAVIGATE AROUND THE WORK AREA IN LIEU OF A FULL DETOUR.





PAGE 80

Work Zone Safety  
Standard Details  
and Drawings

STATIONARY OPERATIONS  
BIKE LANE CLOSURE









POSTED SPEED LIMIT (MPH)	SPACING FOR BIKE ADVANCE WARNING SIGNS (FT) (A,B))	CHANNELIZATION DEVICES (DRUMS OR CONES)			
		TRANSITION LENGTH (L/3)	BUFFER ZONE LENGTH (FT)	DEVICE SPACING (FT)	MIN # OF DEVICES*
25-40	150 / 150	100	305	20	45
45-55	150 / 150	220	495	40	35
60-65	150 / 150	260	645	40	40

\* NUMBER OF DEVICES BASED ON 400 FT WORK ZONE.

**NOTES**

1. DETAIL SHALL BE USED IN CONJUNCTION WITH THE PROPOSED LANE CLOSURE DETAILS. SIGNING SHOWN ONLY FOR BIKE TRAFFIC. FOLLOW ALL OTHER RELEVANT DETAILS FOR TTC DEVICES FOR VEHICULAR TRAFFIC.
2. **\*\*** SIGN SHALL BE USED ONLY IF THERE IS A MARKED BIKE LANE.
3. **\*\*\*** SIGN SHALL BE USED ONLY IF THERE IS NO MARKED BIKE LANE.

**LEGEND**

-  WORK ZONE
-  CHANNELIZATION DEVICE
-  FLASHING ARROW BOARD
-  PORTABLE CHANGEABLE MESSAGE SIGN
-  TRUCK MOUNTED ATTENUATOR
-  RADAR SPEED FEEDBACK BOARD
-  POLICE DETAIL OR UNIFORMED FLAGGER
-  TEMPORARY PORTABLE RUMBLE STRIP
-  TYPE III BARRICADE

NOT TO SCALE

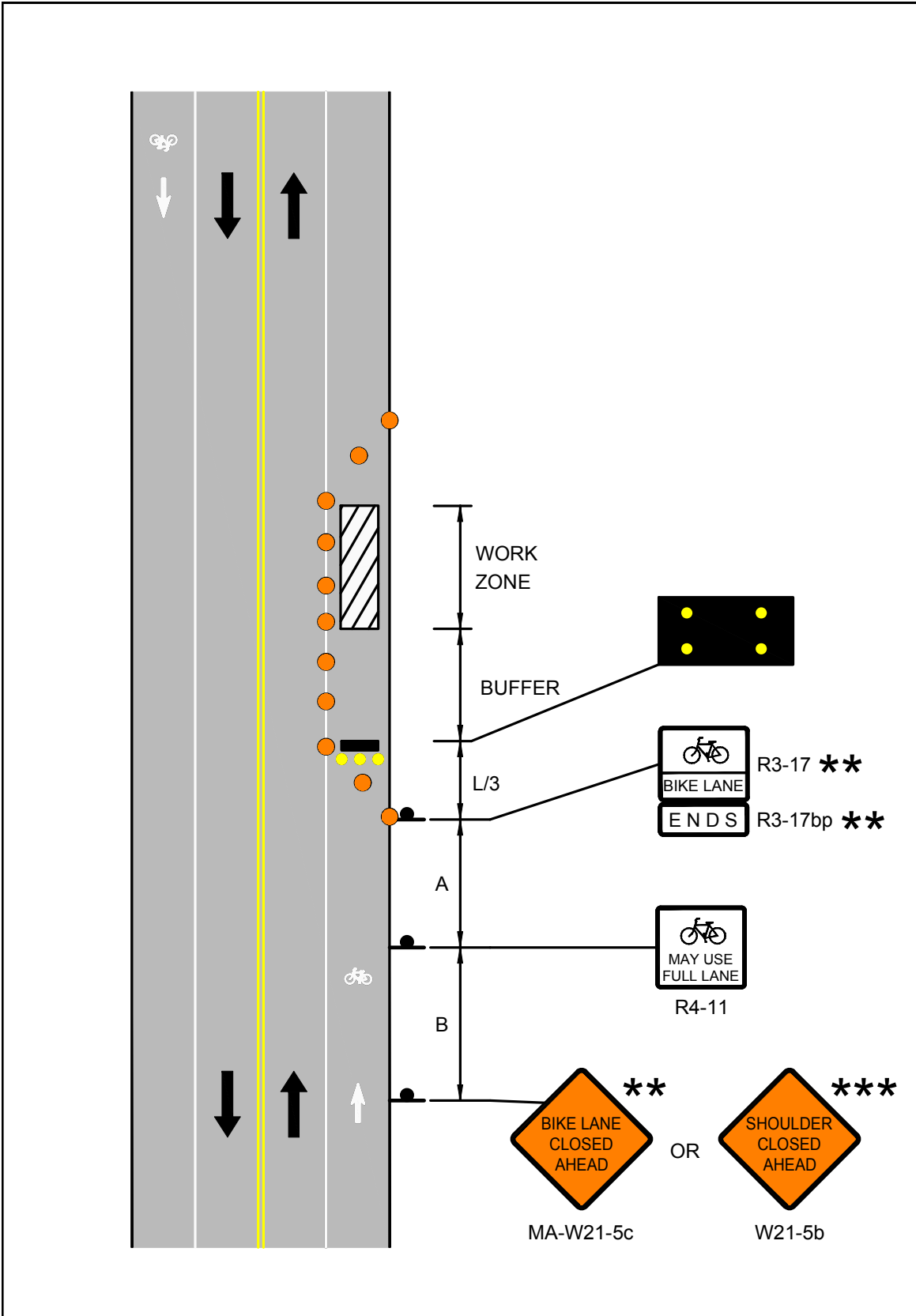

 <p>Massachusetts Department of Transportation Highway Division</p> <p>PAGE 81</p>	<p>Work Zone Safety Standard Details and Drawings</p>	<p>FIGURE 48 STATIONARY OPERATIONS BIKE LANE CLOSURE</p>
---	---	--



**Safety is everyone's business**

Rev. June, 2017