

KEY PLAN
SCALE: 1" = 40'

HIGH POINT ELEV = 14.03
HIGH POINT STA = 105+36.67
PVI STA = 105+50.00
PVI ELEV = 14.57
A.D. = -1.80%
K = 133.33
240' VC

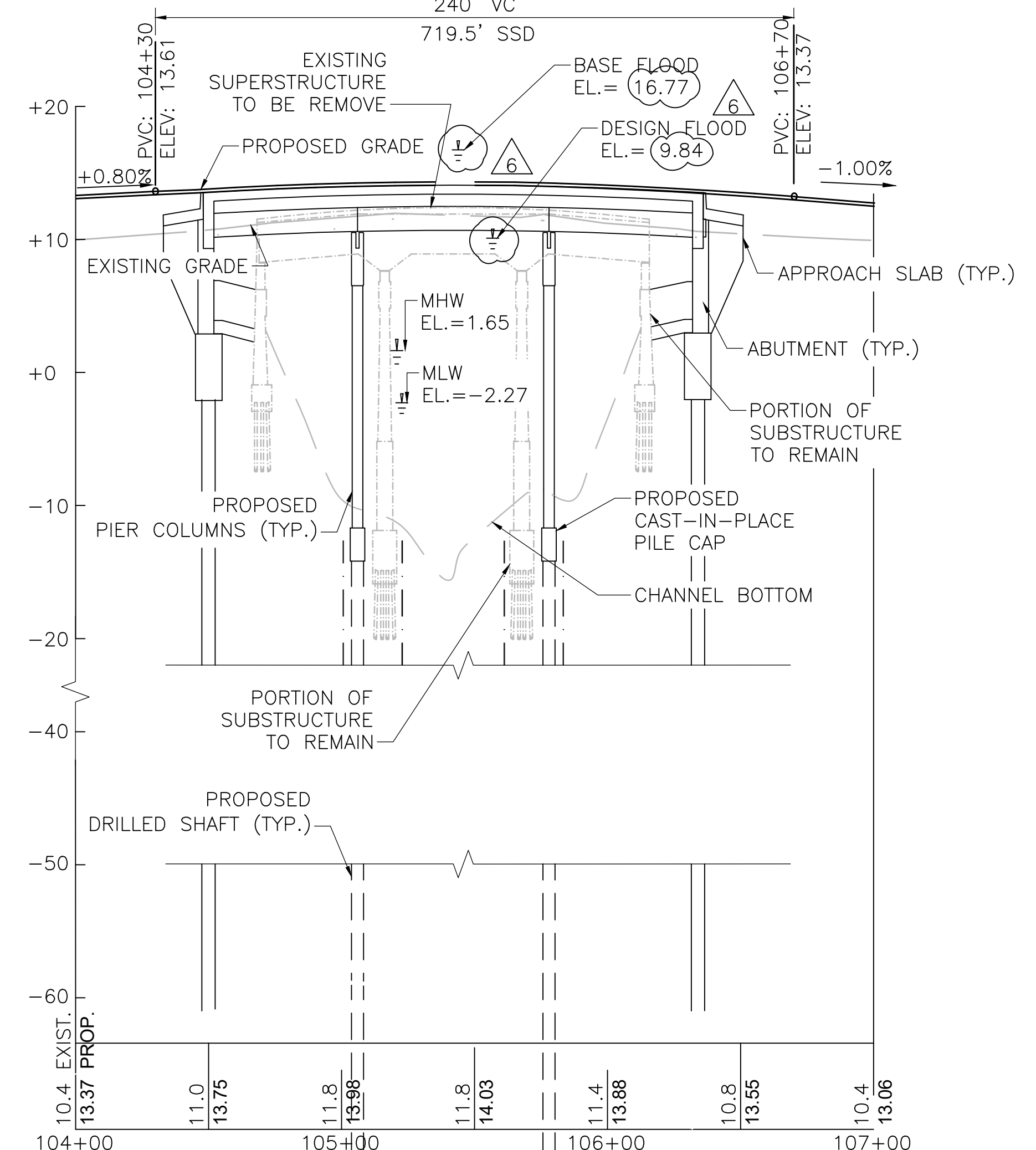

PROFILE ALONG MARION ROAD (US 6)
HORIZONTAL 1" = 40'
VERTICAL 1" = 8'

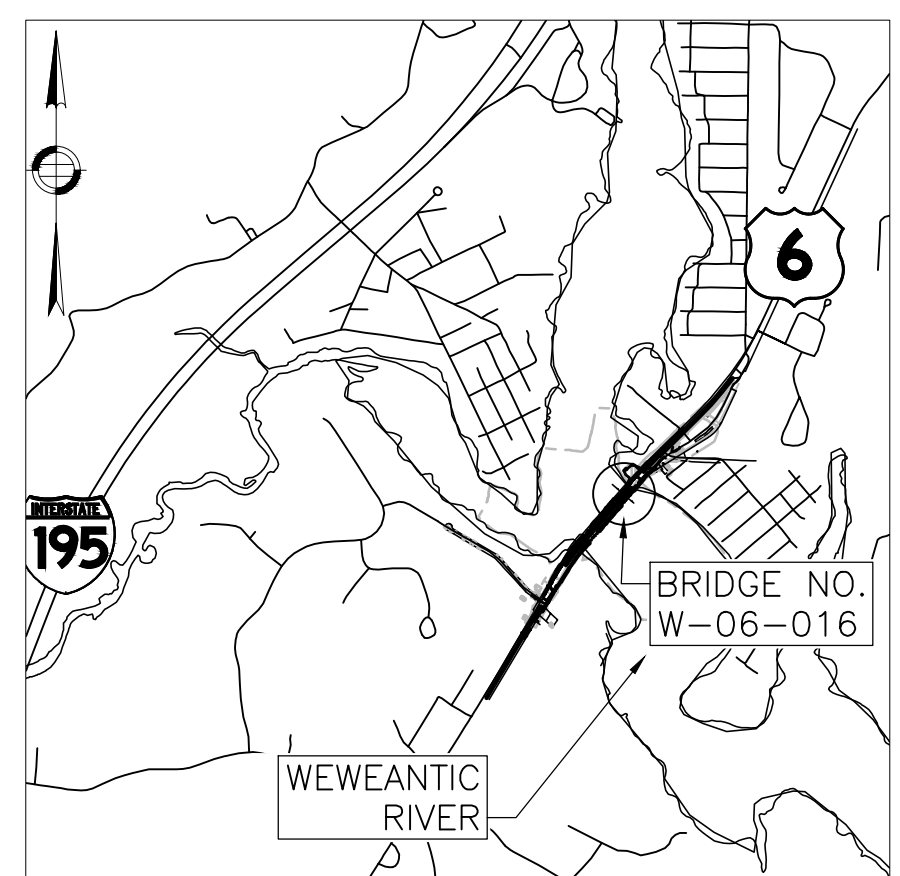

LOCUS
SCALE: 1" = 2000'

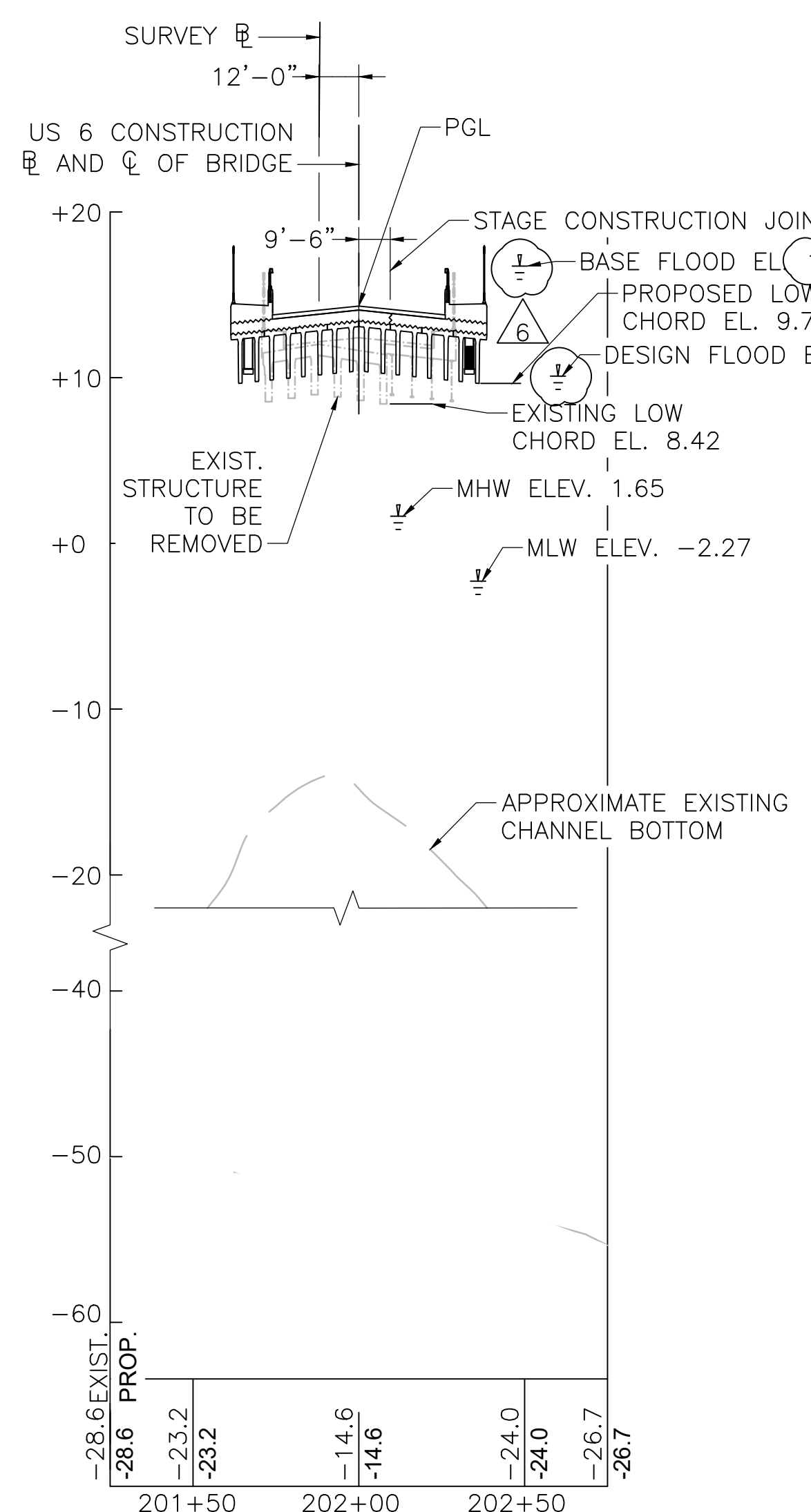

CHANNEL PROFILE (LOOKING UPSTATION)
HORIZONTAL 1" = 40'
VERTICAL 1" = 8'

DESIGN:
IN ACCORDANCE WITH THE 2020 AMERICAN ASSOCIATION OF STATE HIGHWAY AND TRANSPORTATION OFFICIALS (AASHTO) LRFD BRIDGE DESIGN SPECIFICATIONS FOR HL-93 LOADING AND MASSDOT LRFD BRIDGE DESIGN MANUAL - LATEST EDITION.

- NOTES:**
- SEE GEOTECHNICAL DATA REPORT, DATED SEPTEMBER 2024. SEE RFP FOR FURTHER GEOTECHNICAL INFORMATION AND REQUIREMENTS.
 - SEE HYDRAULIC REPORT, STAMP DATED NOVEMBER 5, 2024.
 - NORTH AMERICAN VERTICAL DATUM (NAVD) OF 1988 IS USED THROUGHOUT.
 - MATERIAL REQUIREMENTS SHALL BE IN ACCORDANCE WITH MASSDOT ENGINEERING DIRECTIVES AND RFP REQUIREMENTS.

TRAFFIC DATA		
	ROADWAY OVER	ROADWAY UNDER
DESIGN YEAR	2044	N/A
AVERAGE DAILY TRAFFIC - PRESENT	9,559	N/A
AVERAGE DAILY TRAFFIC - DESIGN YEAR	10,302	N/A
DESIGN HOURLY VOLUME	907	N/A
DIRECTIONAL DISTRIBUTION	DIST	N/A
TRUCK PERCENTAGE - AVERAGE DAY	2.3%	N/A
TRUCK PERCENTAGE - PEAK HOUR	2.45%	N/A
DESIGN SPEED	55 MPH	N/A
DIRECTIONAL DESIGN HOURLY VOLUME	439	N/A

SEISMIC DESIGN CRITERIA	
DESIGN RETURN PERIOD:	1000 YEARS
DESIGN SPECTRA	
As	0.138
SDs	0.290
SD1	0.112
SITE CLASS	E
SEISMIC DESIGN CATEGORY (SDC)	A

HYDRAULIC DESIGN DATA		
DRAINAGE AREA:	89.50	SQ. MILES
DESIGN FLOOD DISCHARGE:	20,320	C.F.S.
DESIGN FLOOD FREQUENCY	25	YEARS
DESIGN FLOOD VELOCITY:	10.27	F.P.S.
DESIGN FLOOD ELEVATION:	9.84	FEET, NAVD

BASE (100-YEAR) FLOOD DATA		
BASE FLOOD DISCHARGE:	N/A	C.F.S.
BASE FLOOD ELEVATION:	16.77	FEET, NAVD

DESIGN AND CHECK SCOUR DATA		
DESIGN SCOUR FLOOD EVENT RETURN FREQUENCY:	25	YEARS
DESIGN FLOOD ABUTMENT SCOUR DEPTH:	45.91	FEET
DESIGN FLOOD PIER SCOUR DEPTH:	41.28	FEET
CHECK SCOUR FLOOD EVENT RETURN FREQUENCY:	100	YEARS
CHECK FLOOD ABUTMENT SCOUR DEPTH:	52.99	FEET
CHECK FLOOD PIER SCOUR DEPTH:	46.60	FEET

FLOOD OF RECORD		
DISCHARGE:	N/A	C.F.S.
FREQUENCY (IF KNOWN):	N/A	YEARS
MAXIMUM ELEVATION:	N/A	FEET, NAVD
DATE:	N/A	MONTH, YEAR
HISTORY OF ICE FLOES:	N/A	N.A.
EVIDENCE OF SCOUR AND EROSION:	N/A	N.A.

PROJECT INFORMATION			
PROJECT FILE NO.:	605311		
PROJECT DESCRIPTION:	PROPOSED BRIDGE		
BRIDGE DESIGN LOADING:	HL-93		
SURVEY:	ELECTRONIC SURVEY BY SURVEY AND MAPPING CONSULTANTS (SMC)		
ELEVATION REFERENCE:	NAVD OF 1988		
BENCH MARK:			
BENCHMARK	N	2730951.302	E 862244.338 8.513
BM	N	2731012.918	E 862341.519 9.915
BM	N	2729975.537	E 861297.506 15.758
BM	N	2730619.515	E 861833.717 17.320
POINT 1550	N	2729590.234	E 861126.664 17.719
BENCHMK	N	2730776.727	E 861969.623 11.500

PARSONS
100 HIGH STREET
BOSTON, MA 02110

massDOT
Massachusetts Department of Transportation
Highway Division

WAREHAM
US 6 (MARION ROAD)
OVER WEWEANTIC RIVER

MASSACHUSETTS DEPARTMENT OF TRANSPORTATION
HIGHWAY DIVISION

APPROVED BY _____ DATE _____

STRUCTURAL ELEMENTS: _____

TITLE: _____

HIGHWAY ELEMENTS: _____

TITLE: _____

605311_Sketch Plan Submittal (SP3) November-2024 2:48 PM

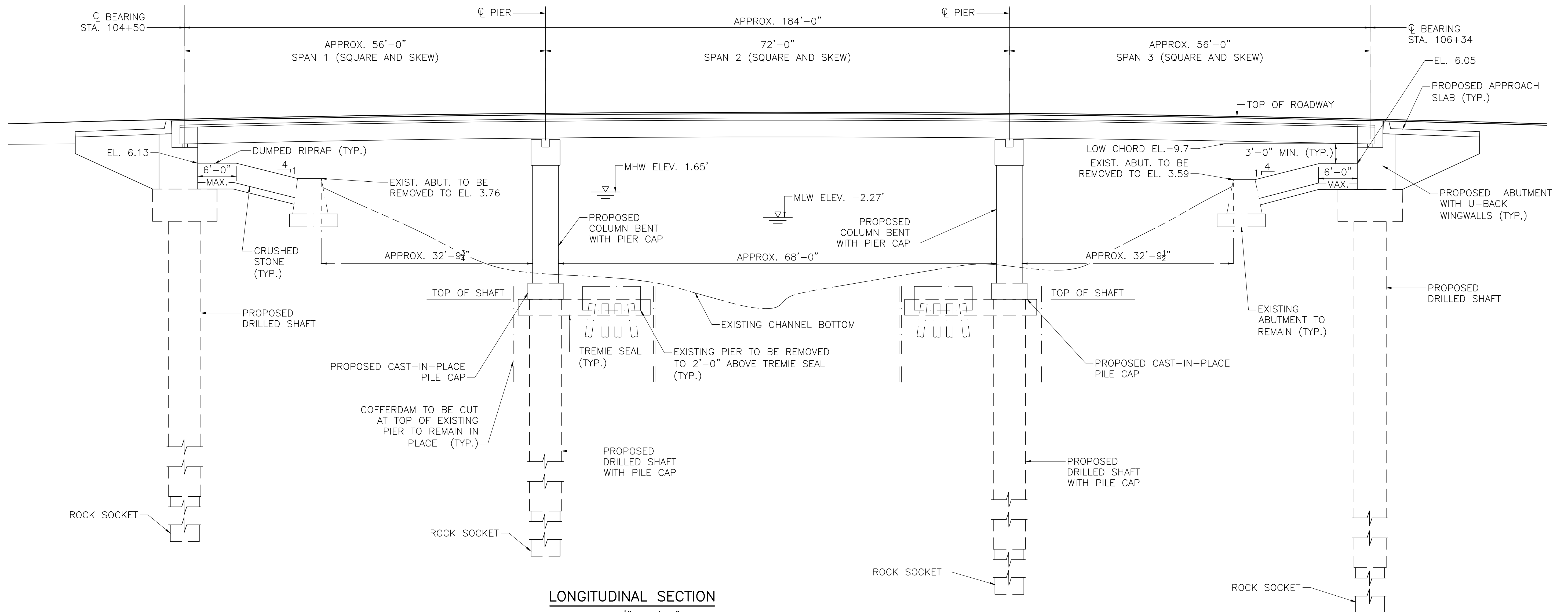

LONGITUDINAL SECTION
SCALE: 1/8" = 1'-0"

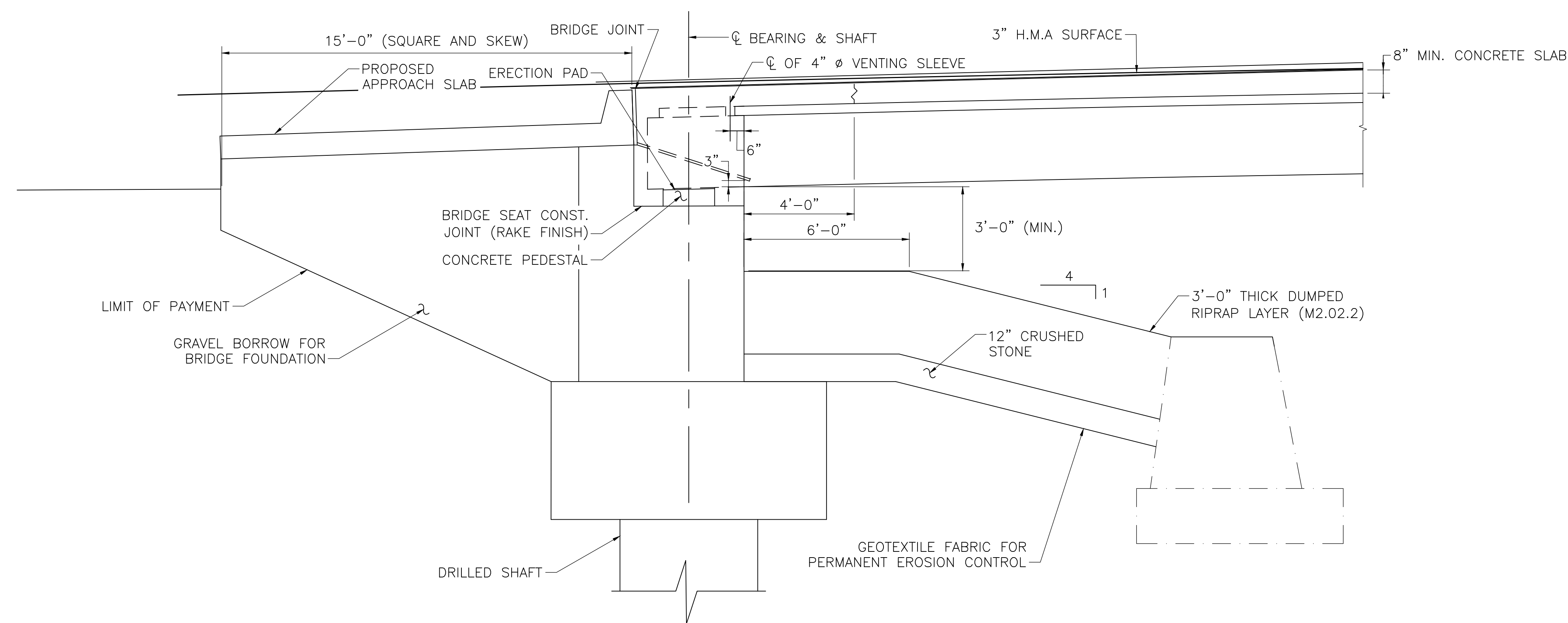

TYPICAL ABUTMENT SECTION
WEST ABUTMENT SHOWN (EAST ABUTMENT SIMILAR)
SCALE: 3/8" = 1'-0"

NOTES:

1. THE DESIGN FACTORED AXIAL COMPRESSIVE LOAD PER PILE IS TBD BY DB ENTITY.
2. BASE TECHNICAL CONCEPT DIMENSIONS SHOWN ARE APPROXIMATE. DESIGN-BUILDER TO ADJUST AS REQUIRED BY FINAL DESIGN WHILE MAINTAINING ALL MINIMUM CONTRACT CLEARANCES.
3. DESIGN-BUILDER TO COORDINATE WITH MASSDOT FOR FUTURE BRIDGE MANUAL INCREASED ALLOWABLE THERMAL MOVEMENT LIMITS FOR USE OF BRIDGE MANUAL STANDARD PAVEMENT SAWCUT DETAILS. DESIGN INTENT IS FOR THE ELIMINATION OF BRIDGE JOINTS.
4. MINIMUM VERTICAL CLEARANCE AT MWH OCCURS AT THE SOUTHERN EXTERIOR GIRDER AT THE WEST END OF THE STRUCTURE. EXISTING VERTICAL CLEARANCE FROM MWH TO THE BOTTOM GIRDER FLANGE IS 4.92', PROPOSED MINIMUM VERTICAL CLEARANCE IS 7.42'.
5. THE DESIGN (25 YEAR) FLOOD ELEVATION IS 9.84', THE BASE (100-YEAR) FLOOD ELEVATION IS 16.77'. 6

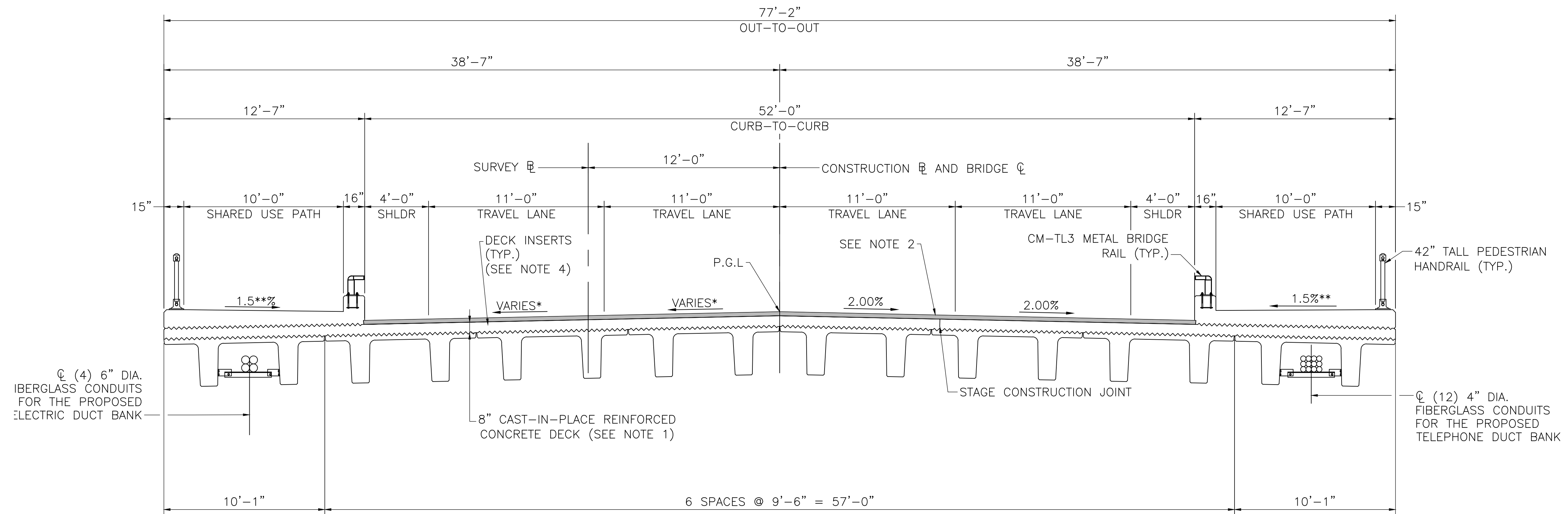

TRANSVERSE SECTION

SCALE: 1/4" = 1'-0"

NOTES:

1. DECK THICKNESS VARIES DUE TO SUPPERELEVATION RUNOUT OVER BRIDGE. APPROXIMATE THICKNESS RANGES FROM 8" TO 12".
2. ^{1 1/4"} SUPERPAVE BRIDGE SURFACE COURSE OVER 1 1/2" SUPERPAVE BRIDGE PROTECTIVE COURSE OVER SPRAY APPLIED MEMBRANE WATERPROOFING.
3. * 0.014% AT EAST ABUT.
0.00% AT PIER
2.00% AT WEST ABUT.

** 2.00% AT EAST ABUT.
2.00% AT PIER
2.00% AT WEST ABUT.
4. DECK INSERTS PROVIDED FOR A POSSIBLE FUTURE ROAD DIET AND ASSOCIATED BARS SHALL BE SIZED TO MATCH THE FACE OF THE SIDEWALK CURB BARS PER THE BRIDGE MANUAL. DECK INSERTS SHALL HAVE A REMOVABLE PLUG INSTALLED PRIOR TO WATERPROOFING AND PAVING.
5. ***SLOPES TO MATCH HIGHWAY DRAWINGS.
6. BASE TECHNICAL CONCEPT DIMENSIONS SHOWN ARE APPROXIMATE. DESIGN-BUILDER TO ADJUST AS REQUIRED BY FINAL DESIGN WHILE MAINTAINING ALL MINIMUM CONTRACT CLEARANCES.

NOTES:

FULL DEPTH PAVEMENT:
 SURFACE:
 1 3/4" SUPERPAVE SURFACE COURSE - 12.5 (SSC-12.5) OVER
 INTERMEDIATE:
 2 1/2" SUPERPAVE INTERMEDIATE COURSE - 19.0 (SIC-19.0) OVER
 BASE:
 4 1/2" SUPERPAVE BASE COURSE - 37.5 (SBC-37.5) OVER
 SUBBASE
 4" DENSE GRADED CRUSHED STONE FOR SUB-BASE OVER
 8" GRAVEL BORROW FOR SUB-BASE

NOTES:

1. THE PILE SIZE AND SPACING IS TBD BY THE DESIGN-BUILDER.
2. EXCAVATION AND LIGHTWEIGHT FILL LIMITS SHOWN ARE TYPICAL FOR CAUSEWAY SECTION AND APPROACH SECTION. LIMITS ARE SUBJECT TO CHANGE BASED ON FINAL DESIGN AND EVALUATION OF RETAINING WALL BY THE DESIGN-BUILDER.
3. CAUSEWAY RETAINING WALL, SHEETING AND LIGHTWEIGHT FILL SHOWN ARE BASED ON CONCEPTUAL DESIGN. ALTERNATE WALL SYSTEM CONCEPTS FOR APPROACH ROADWAYS AND CAUSEWAY REQUIRE SUBMITTAL OF AN ATC WHILE MAINTAINING CONFORMANCE WITH RFP REQUIREMENTS.

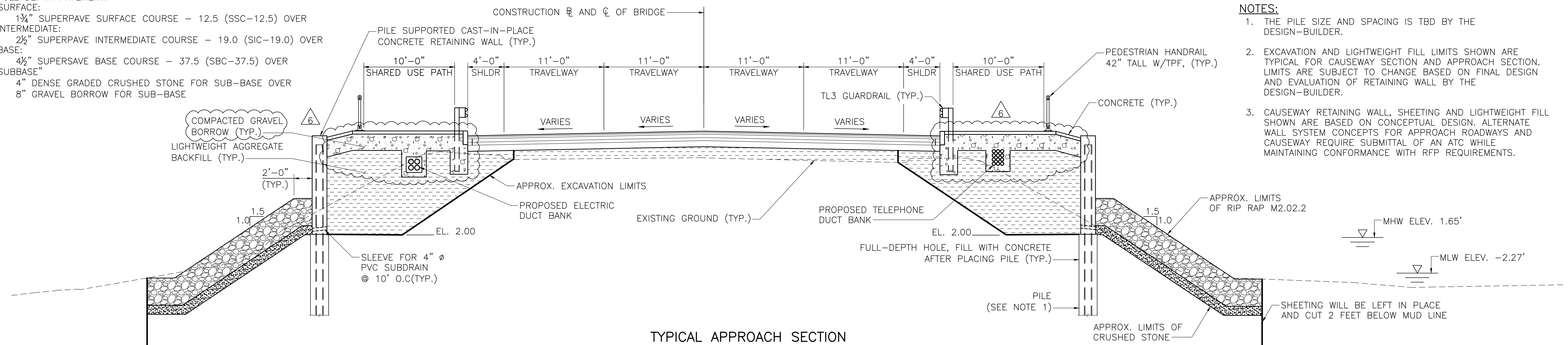

TYPICAL APPROACH SECTION

SCALE: 3/16" = 1'-0"

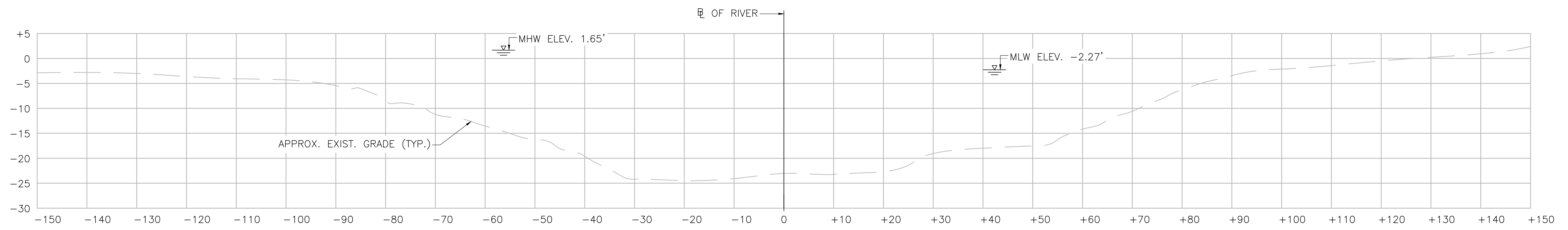

SECTION ACROSS RIVER CL AT STA. 201+38

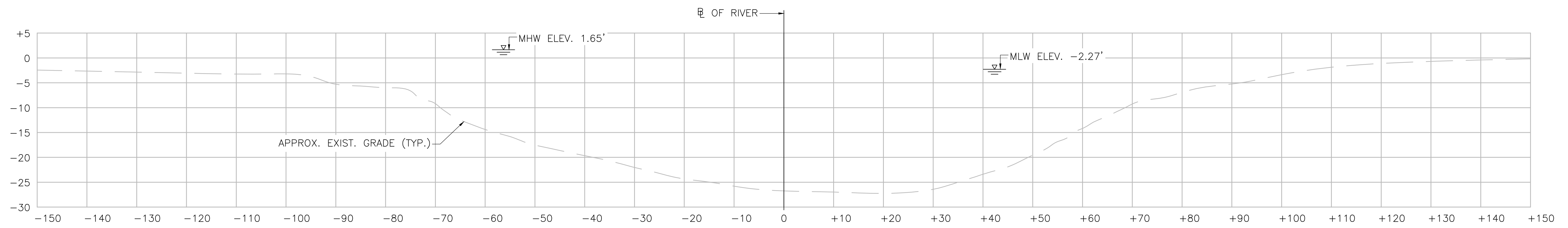

SECTION ACROSS RIVER CL AT STA. 202+62

CHANNEL APPROACH SECTIONS (LOOKING NORTHWEST)

SCALE: 3/32" = 1'-0"

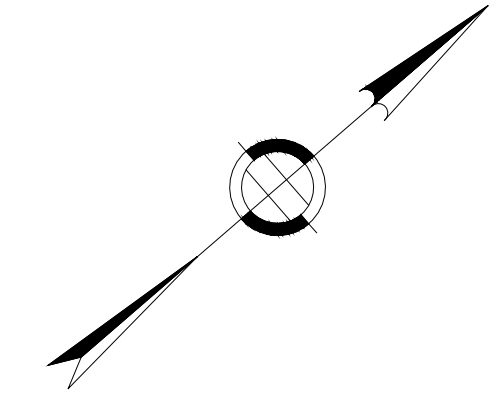

NOTES:

1. BASE TECHNICAL CONCEPT DIMENSIONS SHOWN ARE APPROXIMATE. DESIGN-BUILDER TO ADJUST AS REQUIRED BY FINAL DESIGN.
2. COFFERDAM, SHEETING AND SUPPORT OF EXCAVATION SHOWN IS CONCEPTUAL. DESIGN-BUILDER TO BE RESPONSIBLE FOR PROJECT STAGING, CONSTRUCTION SEQUENCING, LAYOUT OF THE COFFERDAMS, SHEETING AND SUPPORT OF EXCAVATION IN ACCORDANCE WITH THE RFP REQUIREMENTS.

SUGGESTED SEQUENCE OF WATER CONTROL

STAGE 1:

- 1.1 DEMOLISH SOUTHERLY PORTION OF EXISTING STRUCTURE.
- 1.2 INSTALL STAGE 1 PIER COFFERDAM AND TEMPORARY SHEETING.
- 1.3 REMOVE SOUTHERLY PORTION OF PIER AND ABUTMENTS TO SPECIFIED LIMITS.
- 1.4 CONSTRUCT NEW SOUTHERLY PORTION OF PIER AND INTEGRAL ABUTMENTS.
- 1.5 REMOVE STAGE 1 PIER COFFERDAM AND TEMPORARY SHEETING.

STAGE 2:

- 2.1 DEMOLISH NORTHERLY PORTION OF EXISTING SUPERSTRUCTURE.
- 2.2 INSTALL STAGE 2 PIER COFFERDAM AND TEMPORARY SHEETING.
- 2.3 REMOVE NORTHERLY PORTIONS OF THE EXISTING PIER AND ABUTMENTS TO SPECIFIED LIMITS.
- 2.4 CONSTRUCT NEW NORTHERLY PORTION OF PIER AND INTEGRAL ABUTMENTS.
- 2.5 REMOVE STAGE 2 PIER COFFERDAM AND TEMPORARY SHEETING.

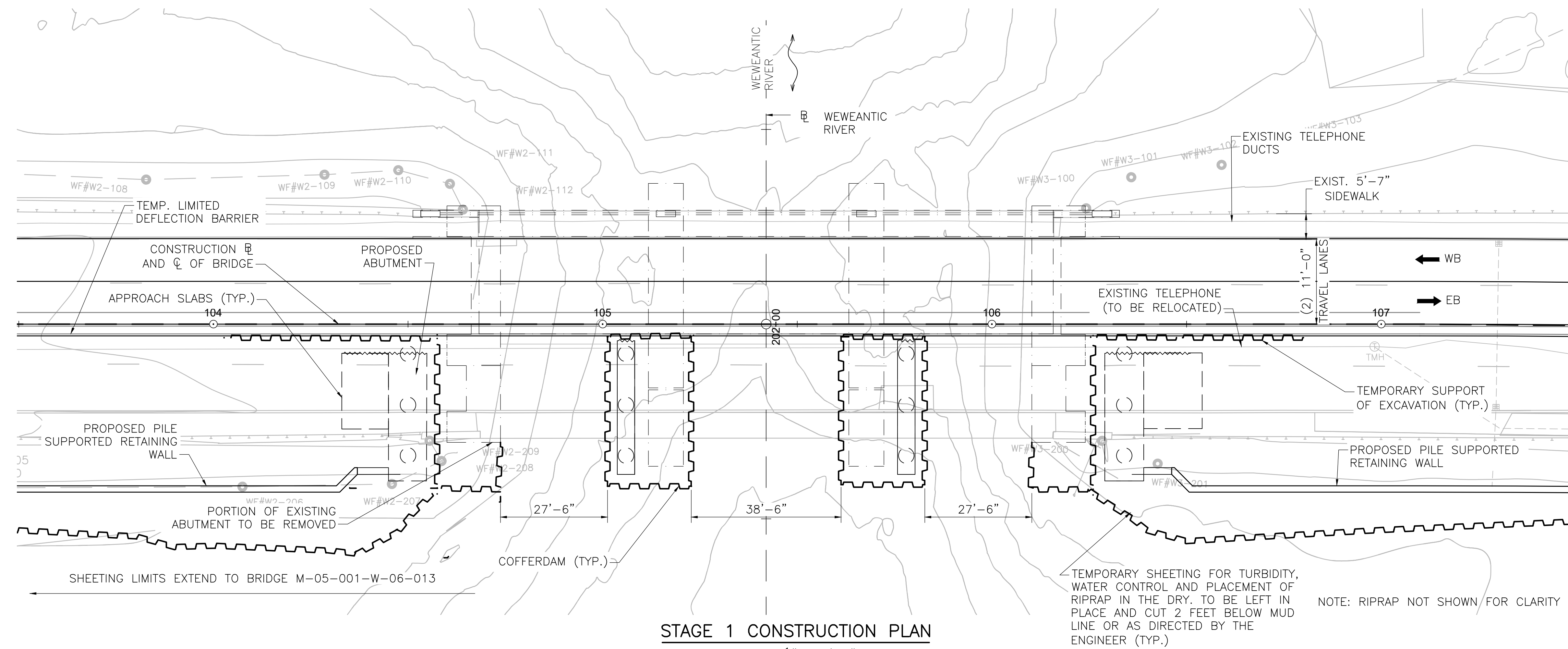

STAGE 1 CONSTRUCTION PLAN

SCALE: 1/16" = 1'-0"

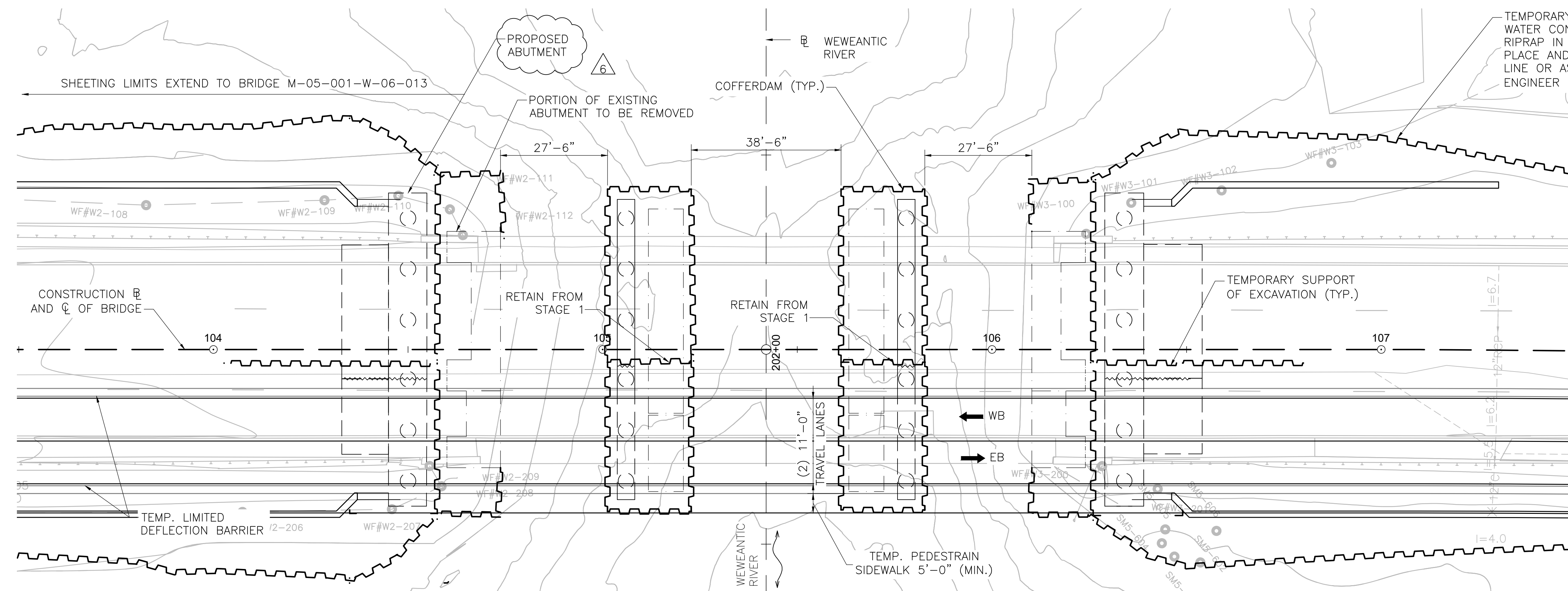

STAGE 2 CONSTRUCTION PLAN

SCALE: 1/16" = 1'-0"

NOTE: RIPRAP NOT SHOWN FOR CLARITY

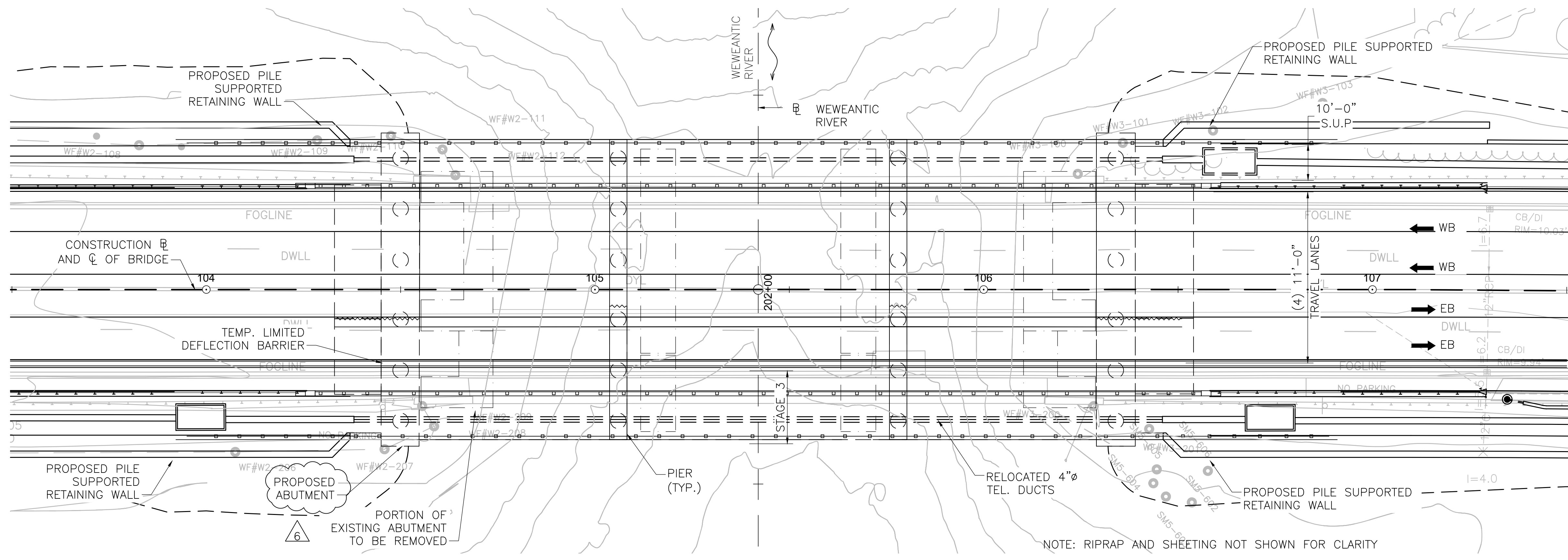

- STAGE 3:
- 3.1 SHIFT TRAFFIC NORTHERLY MAINTAINING FOUR LANES OF TRAFFIC, TWO IN EACH DIRECTION.
 - 3.2 CONSTRUCT SOUTHERLY SHARED USE PATH AND BRIDGE RAIL.

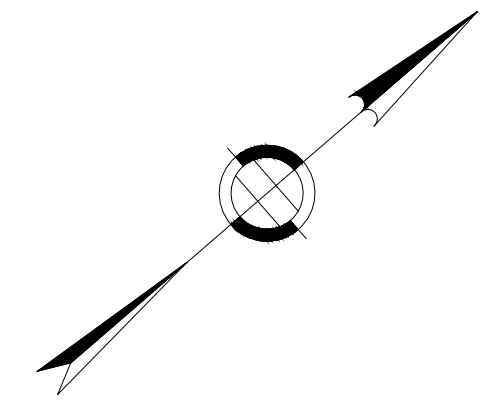

STAGING 3 CONSTRUCTION PLAN

SCALE: 1/16" = 1'-0"

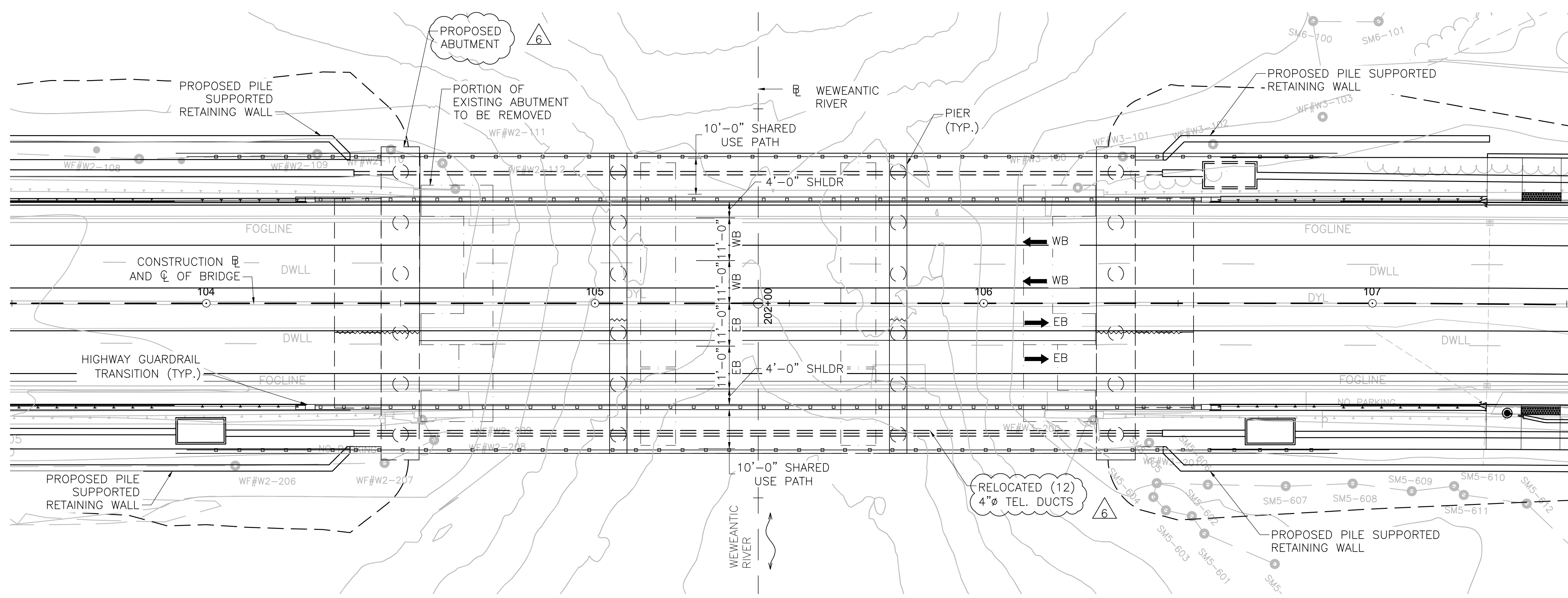

- FINAL STAGE:
- REMOVE BARRIER AND INSTALL SPRAY APPLIED WATER PROOFING MEMBRANE AND HMA WEARING SURFACE.

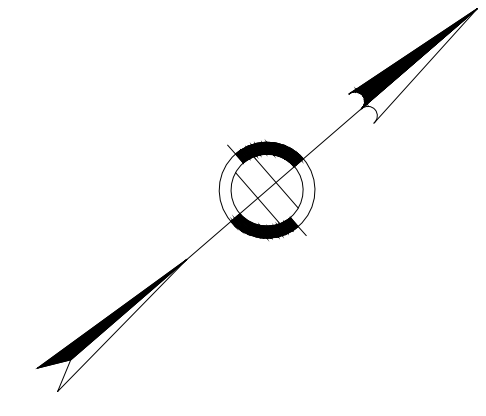

FINAL CONDITION

SCALE: 1/16" = 1'-0"

NOTE: RIPRAP AND SHEETING NOT SHOWN FOR CLARITY

605311_Sketch Plan Submittal (SP3) March-2024